

# High-definition sound processor

## BA3888S

The BA3888S is a sound processor IC that performs phase and harmonic compensation on audio signals to accurately reproduce the "rise" section of audio signals that determines the characteristics of the sound, and thus reproduce the original recording as naturally as possible.

### ●Applications

VCRs, tape recorders and video equipped television

### ●Features

- 1) Corrects distortion in the rising section of audio signals that results from miss-matched speakers and amplifiers, and reproduces the original sound faithfully.
- 2) To allow application with all types of speakers and sources, the clarity can be adjusted using DC control.
- 3) DC control provided for selection of either processor mode or bypass mode.
- 4) Bass boost can be set in the range 0dB to 9dB (Typ.) using external components.
- 5) A noise gate circuit naturally cuts hiss at low volume.

### ●Absolute maximum ratings (Ta = 25°C)

Parameter	Symbol	Limits	Unit
Power supply voltage	V <sub>CC</sub>	13.5	V
Power dissipation	P <sub>d</sub>	1000*	mW
Operating temperature	T <sub>opr</sub>	-10~+70	°C
Storage temperature	T <sub>stg</sub>	-55~+125	°C

\* Reduced by 10mW for each increase in Ta of 1°C over 25°C.

### ●Recommended operating conditions (Ta = 25°C)

Parameter	Symbol	Limits	Unit
Power supply voltage	V <sub>CC</sub>	10.8~13.2	V

● Block diagram

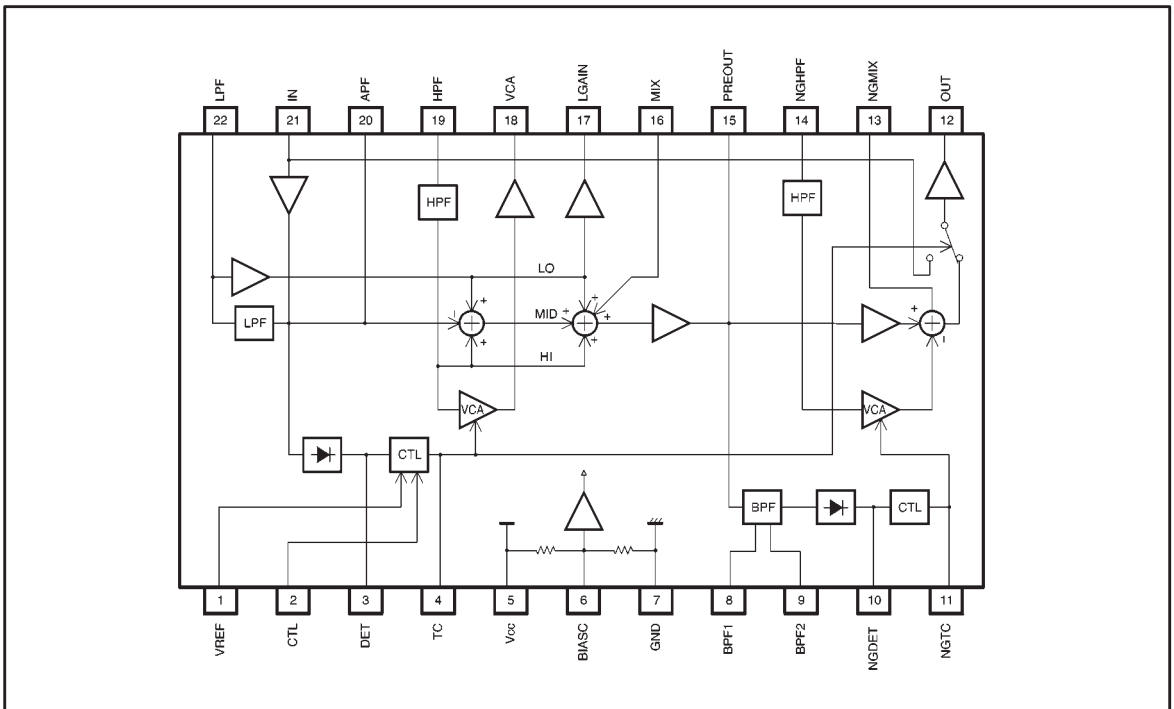

● Electrical characteristics (unless otherwise noted,  $T_a = 25^\circ\text{C}$ ,  $V_{CC} = 12\text{V}$ ,  $f_{IN} = 1\text{kHz}$ ,  $V_{IN} = 10\text{dBV}$ ,  $R_g = 600\Omega$ ,  $R_L = 100\text{k}\Omega$  and  $V_{CTL} = 2.5\text{V}$  and  $V_{ref} = 5\text{V}$ )

Parameter	Symbol	Min.	Typ.	Max.	Unit	Conditions
Circuit current	$I_{CC}$	—	6.3	9.4	mA	$V_{IN}=0V_{rms}$
Voltage gain 1	$G_{V1}$	-1.0	0	1.0	dB	$f_{IN}=400\text{Hz}$ , $V_{CTL}=5\text{V}$
Voltage gain 2	$G_{V2}$	-2.6	-0.6	1.4	dB	$f_{IN}=400\text{Hz}$
Voltage gain 3	$G_{V3}$	-15.3	-13.3	-11.3	dB	$f_{IN}=4\text{kHz}$
Voltage gain 4	$G_{V4}$	9.3	12.3	15.3	dB	$f_{IN}=4\text{kHz}$ , $V_{CTL}=0\text{V}$
Voltage gain 5	$G_{V5}$	-15.3	-13.3	-11.3	dB	$f_{IN}=4\text{kHz}$ , $V_{CTL}=0\text{V}$ , $V_{IN}=-50\text{dBV}$
Voltage gain 6	$G_{V6}$	-2.4	-0.4	1.6	dB	$f_{IN}=40\text{Hz}$ , 16pin-17pin OPEN
Voltage gain 7	$G_{V7}$	6.4	8.4	10.4	dB	$f_{IN}=40\text{Hz}$ , 16pin-17pin SHORT
Maximum output voltage	$V_{OM}$	2.7	3.2	—	$V_{rms}$	THD=1%
Output noise voltage 1	$V_{NO1}$	—	1.2	10	$\mu V_{rms}$	$R_g=0\Omega$ , DIN AUDIO, $V_{CTL}=5\text{V}$
Output noise voltage 2	$V_{NO2}$	—	23	70	$\mu V_{rms}$	$R_g=0\Omega$ , DIN AUDIO
Total harmonic distortion 1	THD1	—	0.001	0.05	%	400Hz~30kHz BPF, $V_{CTL}=5\text{V}$
Total harmonic distortion 2	THD2	—	0.06	0.6	%	400Hz~30kHz BPF
Ripple rejection ratio	RR	50	64	—	dB	$R_g=0\Omega$ , $f_r=100\text{Hz}$ , $V_r=100\text{mV}_{rms}$

Note : When  $V_{CTL} = 5\text{V}$ , the IC is in bypass mode (through operation).

When  $V_{CTL} = 2.5\text{V}$ , the IC is in processor mode (enhance operation) with minimum definition level.

When  $V_{CTL} = 0\text{V}$ , the IC is in processor mode (enhance operation) with maximum definition level.

● Measurement circuit

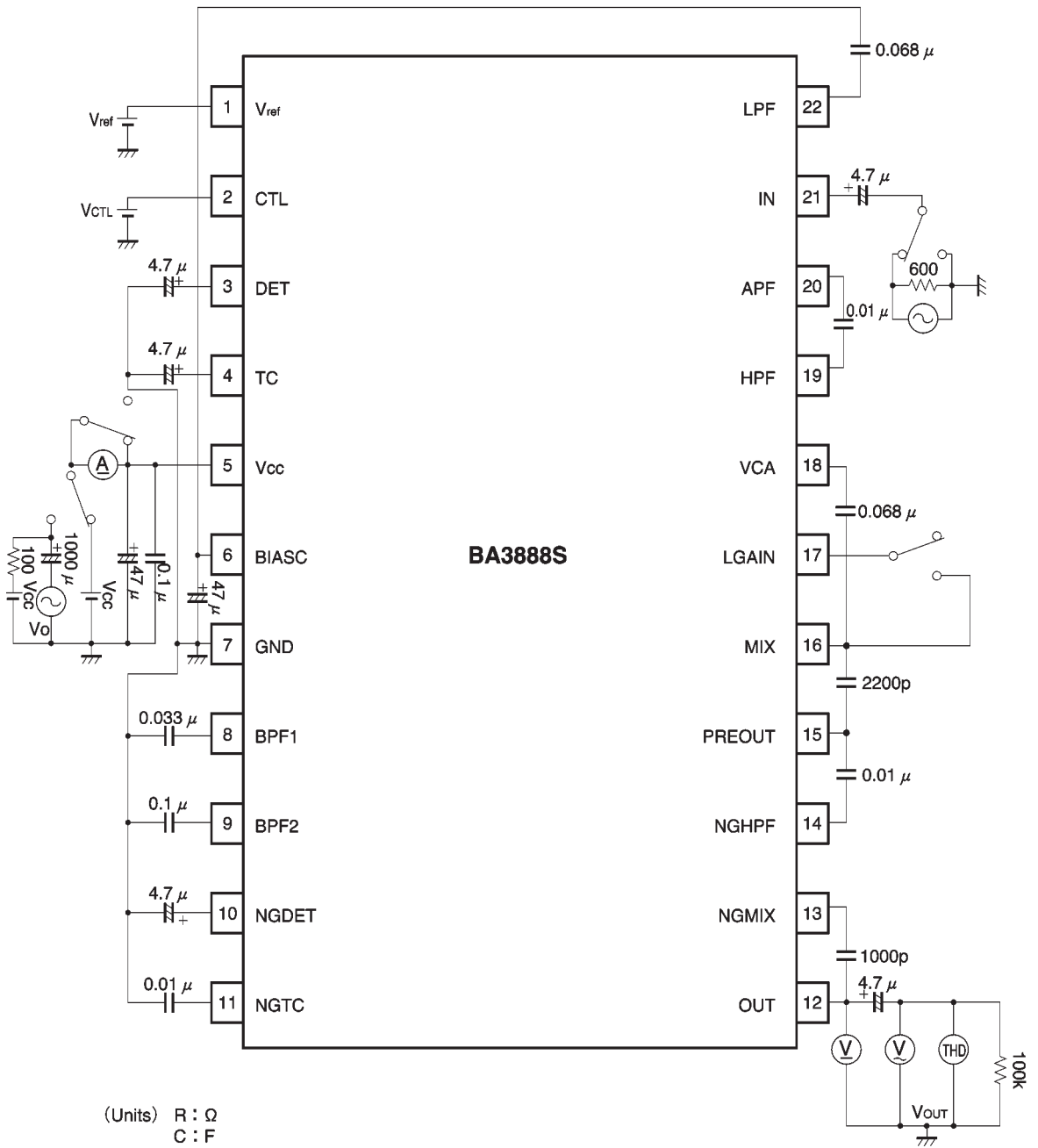

Fig. 1

### ● Circuit operation

The BA3888S high-definition sound processor system IC treats the amplifier and speakers as a total audio system, and performs signal processing at the amplifier input stage to accurately reproduce the rise sections of audio signals that determine the characteristics of sound, and ensure that the replayed audio is as close to the original sound and as natural sounding as possible.

Problems relating to playback of sound on audio systems.

With naturally-generated sound, high-frequency harmonic components generally occur first, followed by the fundamental frequency components. This also applies to the attack section of the sound that characterizes many musical instruments. It is the amplitude component that gives form to the frequency component and envelope at the rising point of sound, and this expresses the characteristics of the sound. Therefore, when replaying audio on audio playback systems, it is extremely important that

the rise section of the signal be expressed accurately with respect to the original sound.

However, there is inevitable mismatching between the speakers and amplifiers in current audio systems. Solid-state power amplifiers use negative feedback techniques and operate off a fixed voltage supply, but as speakers are a current element, mismatching in the system inevitably occurs. In addition, the speaker impedance characteristics are strongly influenced by the electrical reactance of the voice coil, and the mechanical reactance of the cone assembly. As a result of this, distortion is generated in the rising sections of audio signals, causing phase shift in the reproduced sound. In addition, impedance increases in the treble region which reduces the speaker amplitude and reduces the harmonic component, and as a result there is a tendency to masking of large mid-frequency signal components that follow, and this makes it difficult to reproduce the rising sections of the sound.

### ● Operating principle

To solve the problems described above, the BA3888S performs the audio signal processing described below.

Phase shift compensation

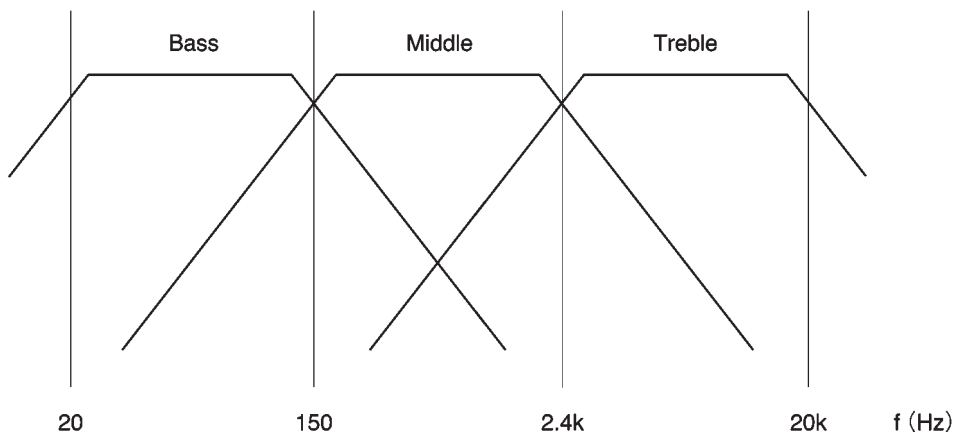

The input signal is separated into three regions : bass (20Hz to 150Hz), middle (150Hz to 2.4kHz) and treble (2.4kHz to 20kHz). These regions are then joined again with the middle and treble regions phase shifted  $-180^\circ$  and  $-360^\circ$  respectively with respect to the bass signal. This phase shift adjusts the delay time characteristic for each band and minimizes the distortion of the rising section of the audio signal.

#### Amplitude compensation (harmonic compensation)

To maintain appropriate auditory balance for the treble region that is made up of harmonic components, a high-speed detector and high-performance VCA circuit are used for amplitude control of the treble component. The amount of compensation is determined from a calculation performed based on the DC level input to the CTL pin, and the DC level detected from the input signal. The internal control signal obtained from this calculation compensates the amplitude of the treble component input to the VCA. This amplitude compensation recovers the harmonic component, and improves the reproduction clarity (definition level) of instruments and vocals.

#### Bass boost

To maintain good balance with the dynamically changing treble component, it is possible to boost the bass component. The amount of bass boost can be set in the range 0dB to 9dB by connecting a resistor between pins 16 and 17. When pins 16 and 17 are not connected, the bass boost is 0dB, (Typ.), and when they are shorted, the bass boost is at its maximum value of 9dB.



#### Noise gate

A high-cut filter is provided to continuously vary the amount of attenuation depending on the input level, and reduce the hiss from tape media that is audible at low volume or on blank sections of tape. This means, that at normal levels, the attenuation of the high-cut filter is minimal, and almost no audio information is lost. As the level becomes smaller, the attenuation of the high-cut filter gradually increases to cut hiss in a natural sounding way.

#### Mode switch

The DC voltage on the CTL pin can be used to switch the IC between processing mode and bypass mode. When processing mode is selected, the audio signal is enhanced using the compensation circuits described above before being output. When bypass mode is selected, the signal bypasses all of the compensation circuits, and only passes through a buffer amplifier before output.

Control table

Item	Threshold level	Mode setting	Definition level
V <sub>CTL</sub>	V <sub>ref</sub>	 Recommended setting range for bypass mode 0.7 × V <sub>ref</sub>	—
	0.6 × V <sub>ref</sub>		Min. (−13dB Typ.)
	0V (GND)	 Recommended setting range for processor mode 0.5 × V <sub>ref</sub>	 Max. (12dB Typ.)

The mode and definition level (treble level) are set by applying a voltage between 0V (GND) and V<sub>ref</sub> to the CTL pin. The maximum voltage V<sub>ref</sub> is the voltage applied to the V<sub>ref</sub> pin.

Recommended range for applied voltage

Pin name	Range	Unit
V <sub>ref</sub>	4.5 ~ V <sub>CC</sub>	V

●Application circuit

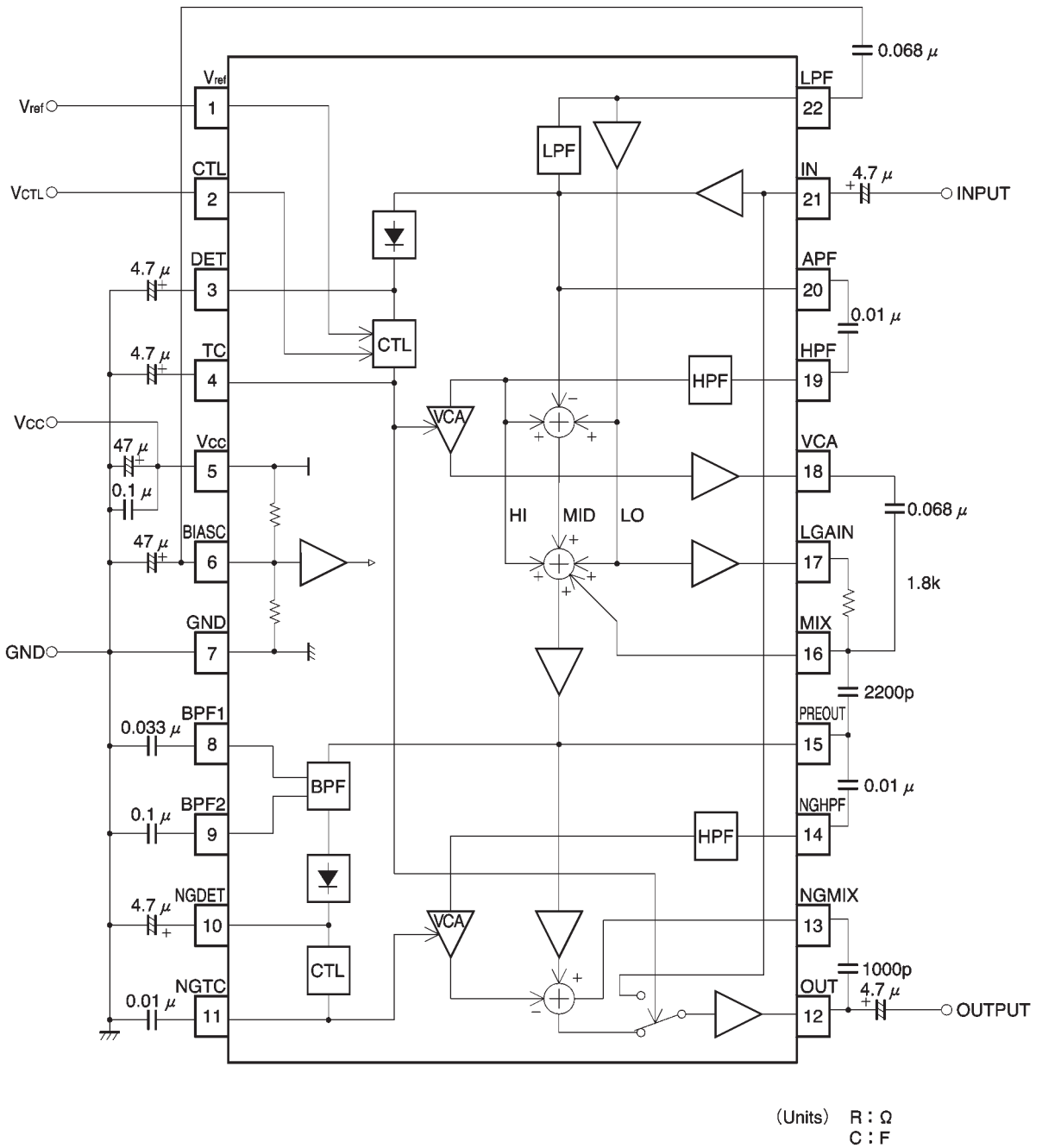

Fig. 2

● Operation notes

(1) Control pin (CTL)

The level of the DC voltage applied to the control pin should be in the range 0V to  $V_{REF}$ . Appropriate switching may not be possible in the region of the threshold voltage. Allow sufficient margin when setting this voltage.

(2) Recommended operating range

Provided the IC is operated within the operating temperature range and within the recommended operating conditions, the general circuit functions are guaranteed to operate correctly, and there will not be significant changes in the electrical characteristics.

(3) Application circuit

Provided the circuit constants in the application example circuit are used, the application circuit should function correctly. However, we recommend that you confirm the characteristics of the circuit in actual use, and take note of the cautionary items described above. If you change the circuit constants, check both the static and transient characteristics of the circuit, and allow sufficient margin to accommodate variations in both the IC and the external components.

(4) License

This IC is manufactured under license from BBE Sound Inc. (U.S.A.). A license agreement with BBE Sound Inc. is required to use this component.

● Electrical characteristics curves

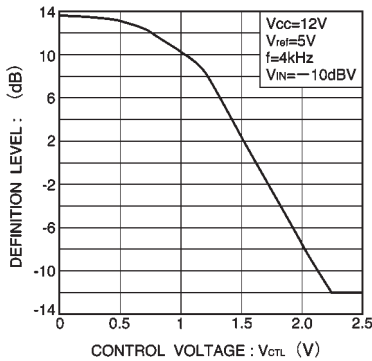

Fig. 3 Definition level vs. control voltage

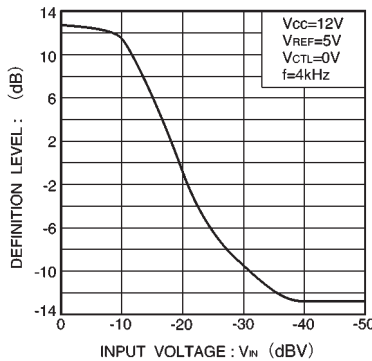

Fig. 4 Definition level vs. input voltage

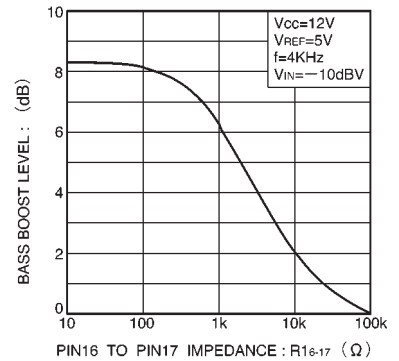

Fig. 5 Bass boost level vs. resistance between pins 16 and 17

● External dimensions (Units: mm)

