

Fluorescent display tube level meter driver, 12-point, VU scale, bar display

BA6146

The BA6146 is a monolithic fluorescent-display tube driver IC. It can drive a 12-point VU-scale bar-level meter over an input range of -20dB to 8dB . The IC has a low-offset rectifier amplifier, and does not require offset adjustment. It also has built-in on/off muting function.

●Applications

Tape deck and amplifier VU meters.

●Features

- 1) Built-in low-offset rectifier amplifier. No offset adjustment required.
- 2) Built-in power supply muting function.
- 3) The input rectifier amplifier can handle both AC and DC input.
- 4) Wide operating power supply voltage range (operates from $V_{CC} = 7.5\text{V}$).
- 5) Low current dissipation (4mA Typ.).

●Block diagram

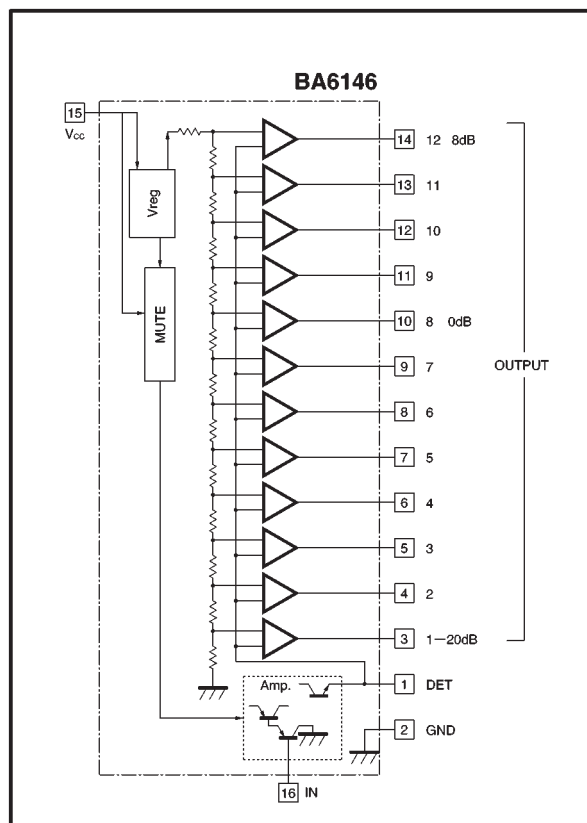

● Absolute maximum ratings (Ta = 25°C)

Parameter	Symbol	Limits	Unit
Power supply voltage	V _{CC}	20	V
Power dissipation	P _d	540*	mW
Operating temperature	T _{opr}	-25~+75	°C
Storage temperature	T _{stg}	-50~+125	°C

* Reduced by 5.4mW for each increase in Ta of 1°C over 25°C.

● Electrical characteristics (unless otherwise noted, Ta = 25°C and V_{CC} = 18V)

Parameter	Symbol	Min.	Typ.	Max.	Unit	Conditions
Power supply voltage	V _{CC}	7.5	18	20	V	—
Quiescent current	I _Q	—	4	8	mA	V _{IN} =0V
Input sensitivity	V _{IN}	65	100	140	mV _{rms}	Pin 8 comparator on level
Comparator level 1	V _{C1}	-24	-20	-16	dB	3pin ON
Comparator level 2	V _{C2}	-17.5	-15	-12.5	dB	4pin ON
Comparator level 3	V _{C3}	-11.5	-10	-8.5	dB	5pin ON
Comparator level 4	V _{C4}	-8	-7	-6	dB	6pin ON
Comparator level 5	V _{C5}	-6	-5	-4	dB	7pin ON
Comparator level 6	V _{C6}	-4	-3	-2	dB	8pin ON
Comparator level 7	V _{C7}	-1.5	-1	-0.5	dB	9pin ON
Comparator level 8	V _{C8}	—	0	—	dB	Pin 10 0dB
Comparator level 9	V _{C9}	0.5	1	1.5	dB	11pin ON
Comparator level 10	V _{C10}	2	3	4	dB	12pin ON
Comparator level 11	V _{C11}	4	5	6	dB	13pin ON
Comparator level 12	V _{C12}	6.5	8	9.5	dB	14pin ON
Pin 1 Comparator level	V _{C1}	60	85	—	mV	3pin ON

● Measurement circuit

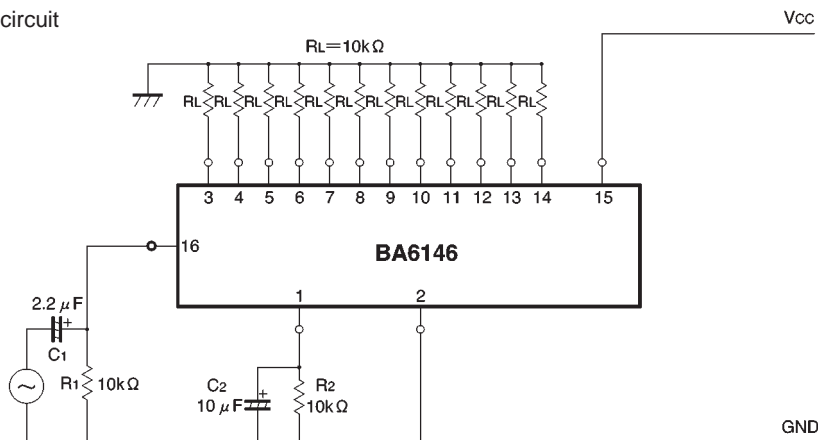

Fig. 1

●Application example

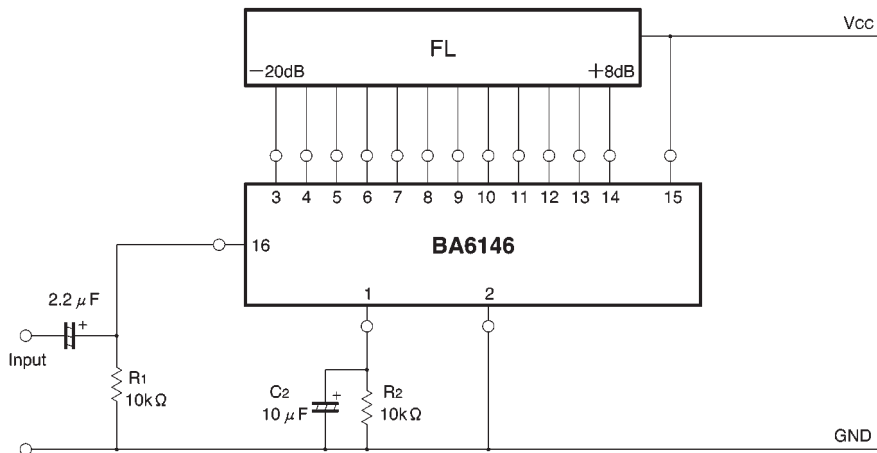

Fig. 2

●Attached components

(1) Input bias resistor: R₁

This resistor is the input impedance.

If the value of the resistor is large, the DC bias voltage will be large, and the input offset will be large and influence the comparator level.

The recommended value for this resistor is 10kΩ.

(2) Time constant setting components for fluorescent tube lighting: C₂ and R₂

C₂ and R₂ approximately determine the recovery time (T_R) according to the following formula.

$$T_R = 2.3 \times C_2 \times R_2$$

The attack time is related to the discharge capacity of the IC and the size of C₂. When C₂ is 10μF, the attack time is approximately 3ms, and when C₂ is 22μF, the attack time is approximately 7ms.

If the value of R₂ is significantly larger than 10kΩ, the comparator level will shift at low levels.

The recommended range is 10kΩ to 25kΩ.

●PCB artwork for the application example circuit

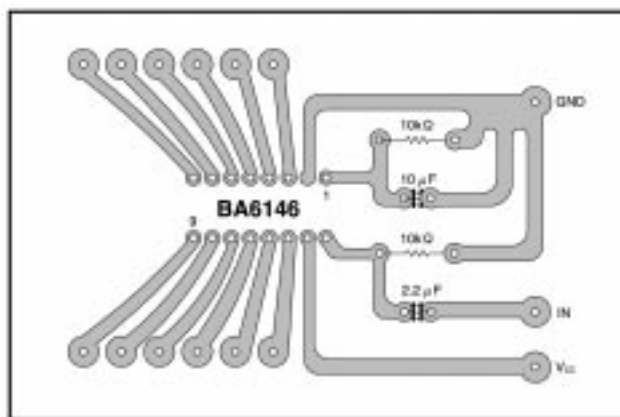

Fig. 3

●Electrical characteristics curves

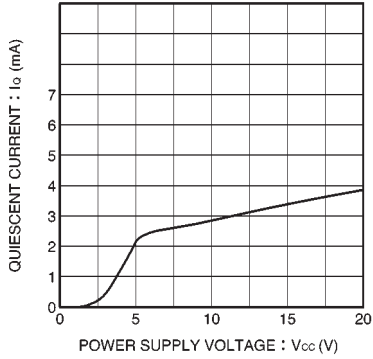

Fig. 4 Quiescent current vs. power supply voltage

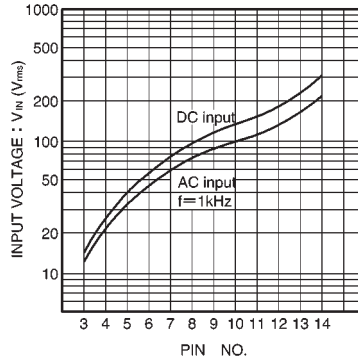

Fig. 5 Lighting input level

●Operation notes

The maximum output current ($I_{OUT Max.}$) is approximately 2mA.

●External dimensions (Units: mm)

