

## Surface Mount Fast Switching Diode

### BAS16T/BAV70T/BAW56T/BAV99T

#### FEATURES

- Ultra-Small surface mount package.
- Fast switching speed.
- For general purpose switching applications.
- High conductance.



Lead-free

#### APPLICATIONS

- General purpose switching application.

#### ORDERING INFORMATION

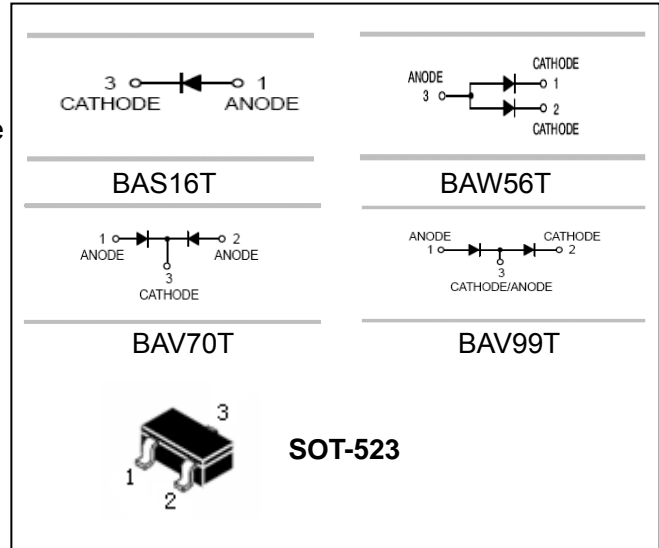

Type No.	Marking	Package Code
BAS16T	A2	SOT-523
BAW56T	JD	SOT-523
BAV70T	JJ	SOT-523
BAV99T	JE	SOT-523

#### MAXIMUM RATING @ Ta=25°C unless otherwise specified

Symbol	Parameter	Value	Units
$V_{RRM}$	Peak repetitive reverse voltage	85	V
$V_{RWM}$	Working peak reverse voltage		
$V_R$	DC reverse voltage		
$V_{R(RMS)}$	RMS reverse voltage	60	V
$I_F$	Forward continuous voltage	single diode	155
		double diode	75
$I_{FRM}$	Repetitive peak forward current	500	mA
$I_{FSM}$	Non-repetitive peak forward surge current	@t=1.0μs	4.0
		@t=1.0ms	1.0
		@t=1.0s	0.5
$P_d$	Power dissipation	150	mW
$R_{\theta JA}$	Thermal resistance junction to ambient	833	°C/W
$T_j, T_{stg}$	Junction and Storage Temperature	-65 to +150	°C

## Surface Mount Fast Switching Diode

### BAS16T/BAV70T/BAW56T/BAV99T

#### ELECTRICAL CHARACTERISTICS @ Ta=25°C unless otherwise specified

Parameter	Symbol	Test conditions	MIN	MAX	UNIT
Reverse breakdown voltage	$V_{(BR)R}$	$I_R=100\mu A$	85		V
Leakage current	$I_R$	$V_R=75V$		2.0	$\mu A$
		$V_R=75V, T_j=150^\circ C$		100	$\mu A$
		$V_R=25V, T_j=150^\circ C$		60	$\mu A$
		$V_R=25V$		30	nA
Forward voltage	$V_F$	$I_F=1.0mA$		0.715	V
		$I_F=10mA$		0.855	
		$I_F=50mA$		1.0	
		$I_F=150mA$		1.25	
Transition frequency	$f_T$	$V_{CE}=5V, I_C=10mA, f=100KHz$	100		MHz
Typical total capacitance	$C_T$	$V_R=0V, f=1MHz$		1.5	pF
Reverse recovery Time	$t_{rr}$	$I_F=I_R=10mA, I_{rr}=0.1 \cdot I_R, R_L=100\Omega$		4.0	ns

#### TYPICAL CHARACTERISTICS @ Ta=25°C unless otherwise specified

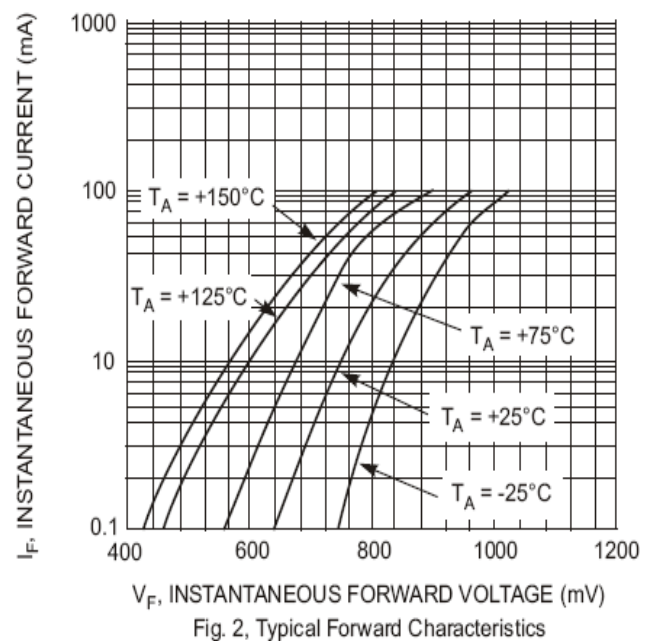
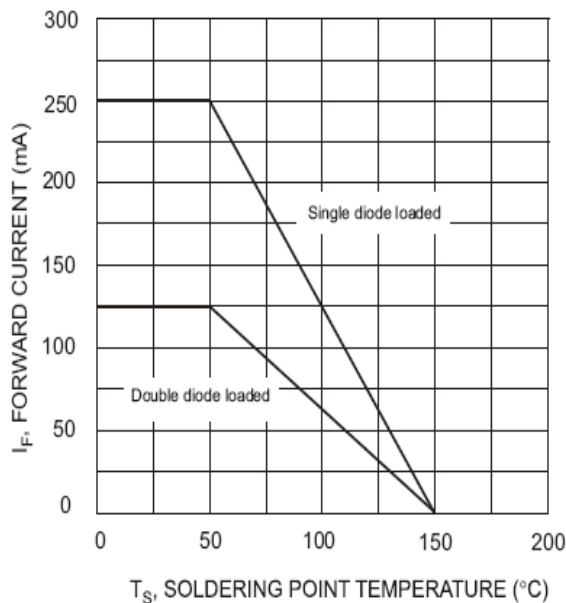

## Surface Mount Fast Switching Diode

BAS16T/BAV70T/BAW56T/BAV99T

### PACKAGE OUTLINE

Plastic surface mounted package

SOT-523

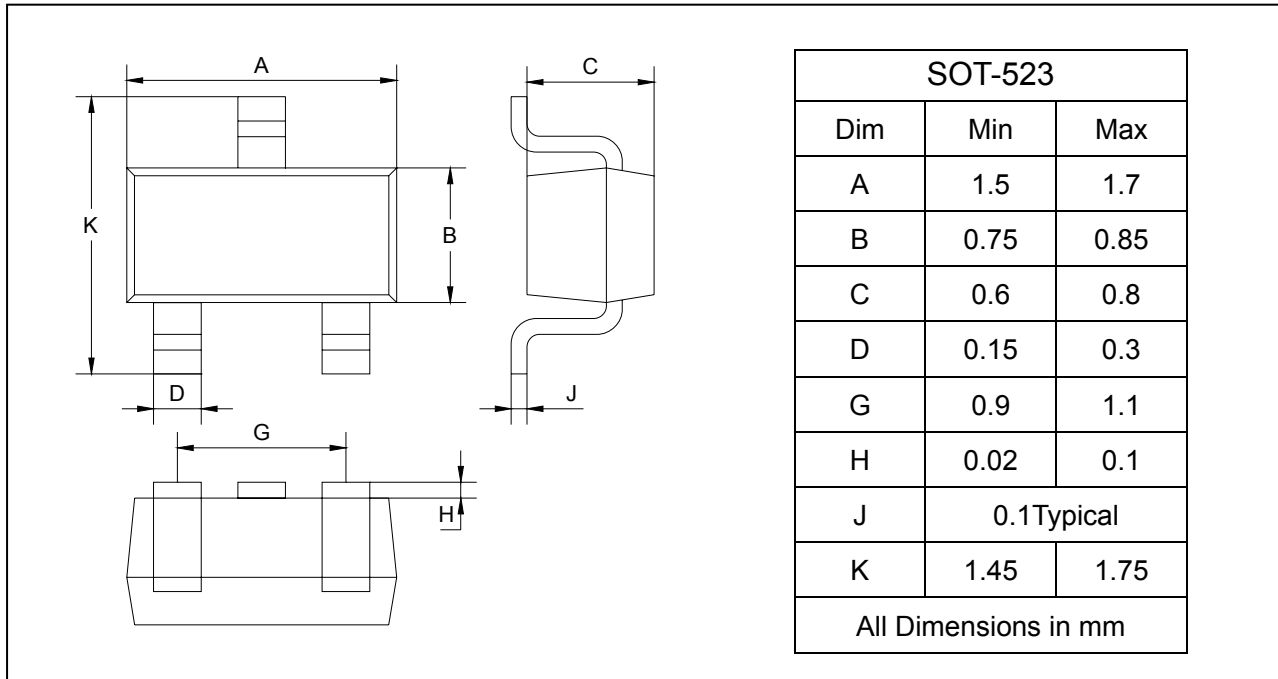

### SOLDERING FOOTPRINT

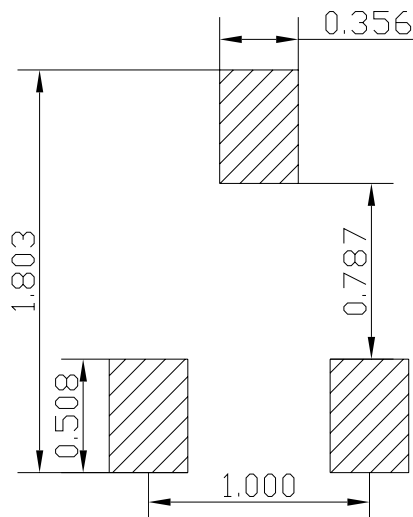

Unit : mm

### PACKAGE INFORMATION

Device	Package	Shipping
BAS16T/BAW56T/BAV70T/BAV99T	SOT-523	3000/Tape&Reel