



BC817

NPN SILICON TRANSISTOR

NPN GENERAL PURPOSE AMPLIFIER

■ DESCRIPTION

The UTC **BC817** is designed for general purpose medium power amplifiers and switches requiring collector currents to 1.2A.

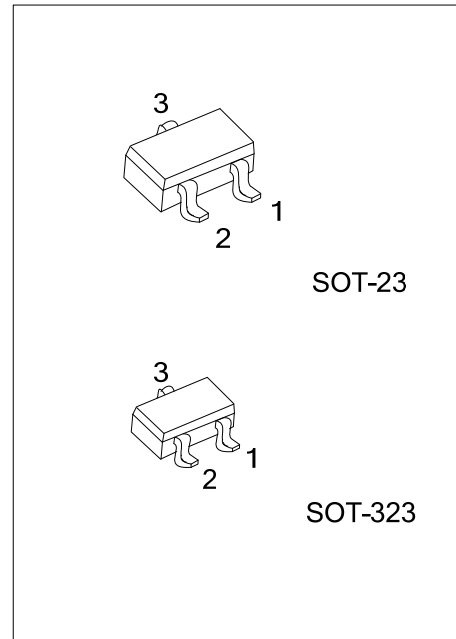

Lead-free: BC817L
Halogen-free: BC817G

■ ORDERING INFORMATION

Ordering Number			Package	Pin Assignment			Packing
Normal	Lead Free	Halogen Free		1	2	3	
BC817-x-AE3-R	BC817L-x-AE3-R	BC817G-x-AE3-R	SOT-23	E	B	C	Tape Reel
BC817-x-AL3-R	BC817L-x-AL3-R	BC817G-x-AL3-R	SOT-323	E	B	C	Tape Reel

<p>BC817L-x-AE3-R</p> <p>(1)Packing Type (2)Package Type (3)Rank (4)Lead Plating</p>	<p>(1) R: Tape Reel (2) AE3: SOT-23, AL3: SOT-323 (3) x: refer to Classification of h_{FE} (4) G: Halogen Free, L: Lead Free, Blank: Pb/Sn</p>
--	--

■ MARKING

BC817-16	BC817-25	BC817-40
<p>L: Lead Free G: Halogen Free</p>	<p>L: Lead Free G: Halogen Free</p>	<p>L: Lead Free G: Halogen Free</p>

■ ABSOLUTE MAXIMUM RATINGS (Ta=25°C, unless otherwise specified)

PARAMETER		SYMBOL	RATINGS	UNIT
Collector-Base Voltage		V_{CES}	50	V
Collector-Emitter Voltage		V_{CEO}	45	V
Emitter-Base Voltage		V_{EBO}	5.0	V
Collector Current -Continuous		I_C	1.5	A
Collector Dissipation	SOT-23	P_C	310	mW
	SOT-323		200	mW
Junction Temperature		T_J	+150	°C
Storage Temperature		T_{STG}	-65 ~ +150	°C

Note: Absolute maximum ratings are those values beyond which the device could be permanently damaged.

Absolute maximum ratings are stress ratings only and functional device operation is not implied.

■ ELECTRICAL CHARACTERISTICS (Ta=25°C, unless otherwise specified)

PARAMETER	SYMBOL	TEST CONDITIONS	MIN	TYP	MAX	UNIT
OFF CHARACTERISTICS						
Collector-Emitter Breakdown Voltage	BV_{CEO}	$I_C=10mA, I_B=0$	45			V
Collector-Base Breakdown Voltage	BV_{CES}	$I_C=100\mu A, I_E=0$	50			V
Emitter-Base Breakdown Voltage	BV_{EBO}	$I_E=10\mu A, I_C=0$	5			V
Collector Cut-OFF Current	I_{CBO}	$V_{CB}=20V$			100	nA
		$V_{CB}=20V, T_a=150^\circ C$			5	μA
ON CHARACTERISTICS						
DC Current Gain	h_{FE1}	$I_C=100mA, V_{CE}=1.0V$	See Classification			
	h_{FE2}	$I_C=500mA, V_{CE}=1.0V$	40			
Collector-Emitter Saturation Voltage	$V_{CE(SAT)}$	$I_C=500mA, I_B=50mA$			0.7	V
Base-Emitter On Voltage	$V_{BE(ON)}$	$I_C=500mA, V_{CE}=1.0V$			1.2	V

■ CLASSIFICATION OF h_{FE1}

RANK	16	25	40
RANGE	100-250	160-400	250-600

TYPICAL CHARACTERISTICS

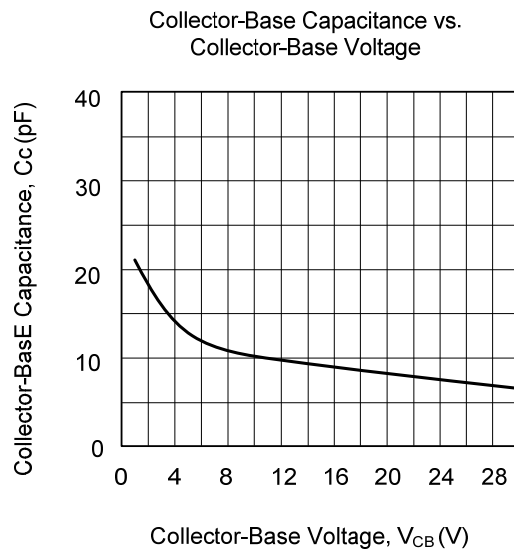
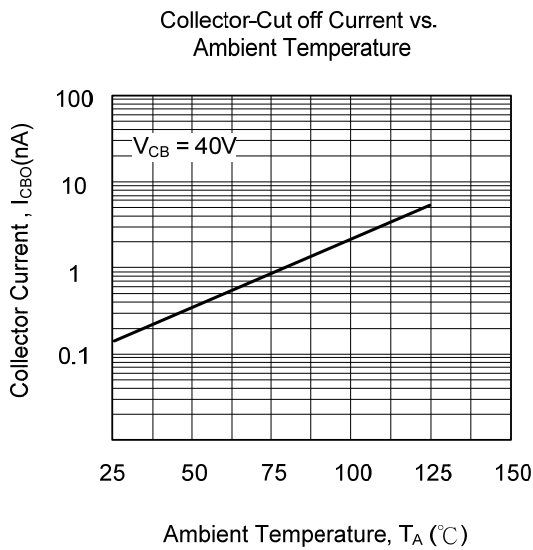
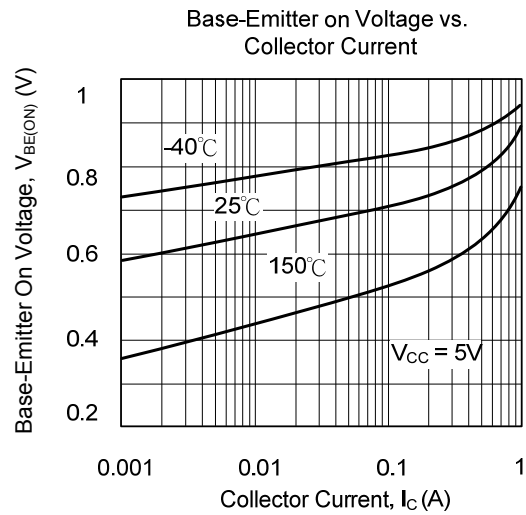
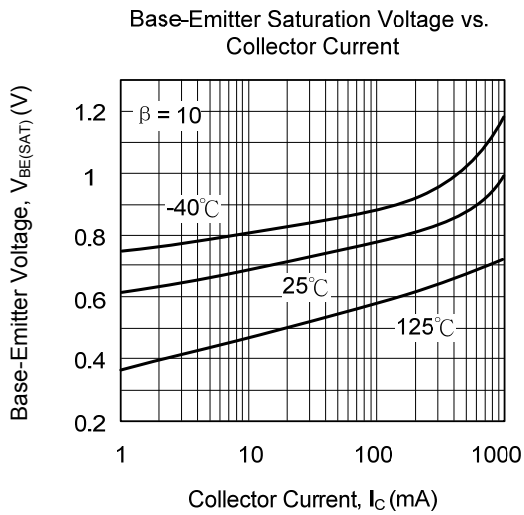
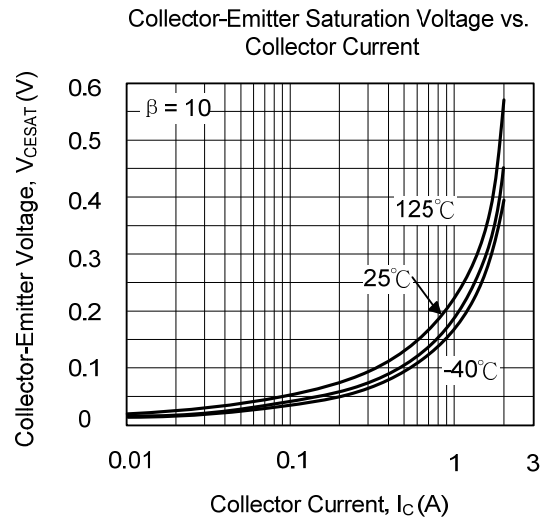
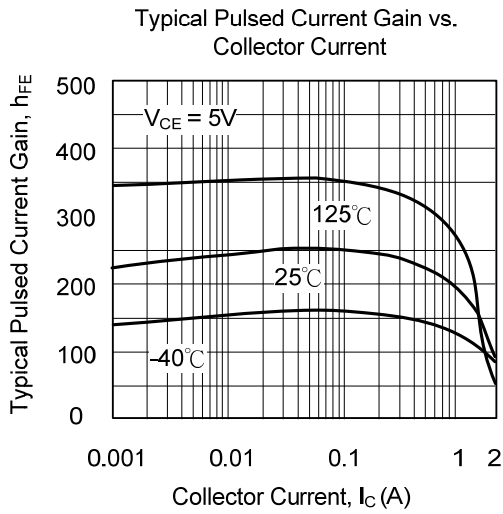

■ TYPICAL CHARACTERISTICS(Cont.)

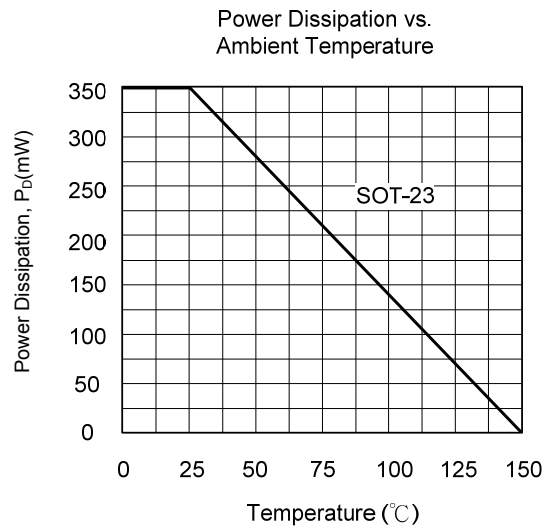
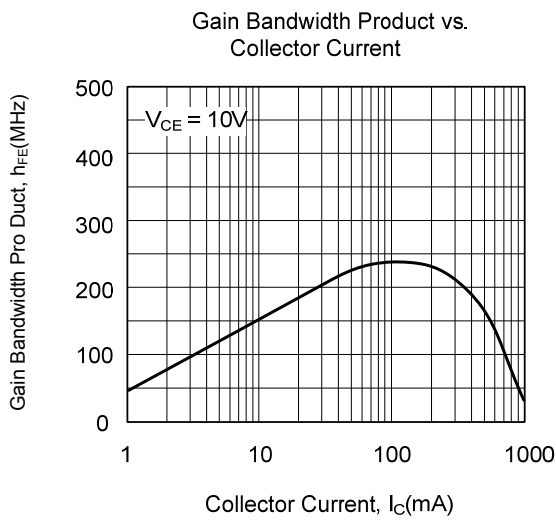

UTC assumes no responsibility for equipment failures that result from using products at values that exceed, even momentarily, rated values (such as maximum ratings, operating condition ranges, or other parameters) listed in products specifications of any and all UTC products described or contained herein. UTC products are not designed for use in life support appliances, devices or systems where malfunction of these products can be reasonably expected to result in personal injury. Reproduction in whole or in part is prohibited without the prior written consent of the copyright owner. The information presented in this document does not form part of any quotation or contract, is believed to be accurate and reliable and may be changed without notice.