



BC856/BC857/BC858

PNP SILICON TRANSISTOR

SWITCHING AND AMPLIFIER APPLICATIONS

■ **FEATURES**

*Suitable for automatic insertion in thick and thin-film circuits

*Complement to BC846/BC847/BC848

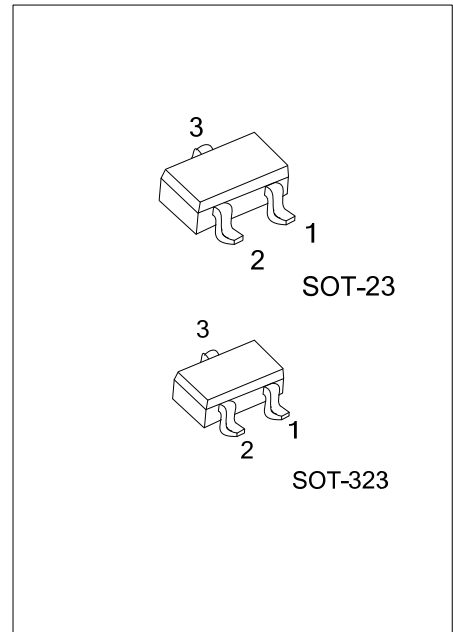

■ **ORDERING INFORMATION**

Ordering Number			Package	Pin Assignment			Packing
Normal	Lead Free	Halogen Free		1	2	3	
BC856-x-AE3-R	BC856L-x-AE3-R	BC856G-x-AE3-R	SOT-23	E	B	C	Tape Reel
BC857-x-AE3-R	BC857L-x-AE3-R	BC857G-x-AE3-R	SOT-23	E	B	C	Tape Reel
BC858-x-AE3-R	BC858L-x-AE3-R	BC858G-x-AE3-R	SOT-23	E	B	C	Tape Reel
BC856-x-AL3-R	BC856L-x-AL3-R	BC856G-x-AL3-R	SOT-323	E	B	C	Tape Reel
BC857-x-AL3-R	BC857L-x-AL3-R	BC857G-x-AL3-R	SOT-323	E	B	C	Tape Reel
BC858-x-AL3-R	BC858L-x-AL3-R	BC858G-x-AL3-R	SOT-323	E	B	C	Tape Reel

<p>BC856L-x-AE3-R</p>	<p>(1) R: Tape Reel (2) AE3: SOT-23, AL3: SOT-323 (3) x: refer to Classification of h_{FE} (4) G: Halogen Free, L: Lead Free, Blank: Pb/Sn</p>
-----------------------	--

■ **MARKING(SOT-23/SOT-323)**

BC856	BC857	BC858

X: Rank Code, refer to Classification of h_{FE}

□: L: Lead Free, G: Halogen Free

BC856/BC857/BC858

PNP SILICON TRANSISTOR

■ ABSOLUTE MAXIMUM RATINGS (Ta=25°C, unless otherwise specified)

PARAMETER	SYMBOL	RATINGS	UNIT
Collector-Base Voltage	BC856	-80	V
	BC857	-50	V
	BC858	-30	V
Collector-Emitter Voltage	BC856	-65	V
	BC857	-45	V
	BC858	-30	V
Emitter-Base Voltage	V _{EBO}	-5	V
Collector Dissipation	P _D	310	mW
Collector Current (DC)	I _C	-100	mA
Junction Temperature	T _J	+150	°C
Storage Temperature	T _{STG}	-40 ~ +150	°C

Note: Absolute maximum ratings are those values beyond which the device could be permanently damaged. Absolute maximum ratings are stress ratings only and functional device operation is not implied.

■ ELECTRICAL CHARACTERISTICS (Ta=25°C, unless otherwise specified)

PARAMETER	SYMBOL	TEST CONDITIONS	MIN	TYP	MAX	UNIT
Collector Cut-Off Current	I _{CBO}	V _{CB} =-30V, I _E =0			-15	nA
DC Current Gain	h _{FE}	V _{CE} =-5V, I _C =-2mA	110		800	
Collector-Emitter Saturation Voltage	V _{CE(SAT)}	I _C =-10mA, I _B =-0.5mA		-90	-300	mV
		I _C =-100mA, I _B =-5mA		-250	-650	mV
Base-Emitter Saturation Voltage	V _{BE(SAT)}	I _C =-10mA, I _B =-0.5mA		-700		mV
		I _C =-100mA, I _B =-5mA		-900		mV
Base-Emitter On Voltage	V _{BE(ON)}	V _{CE} =-5V, I _C =-2mA	-600	-660	-750	mV
		V _{CE} =-5V, I _C =-10mA			-800	mV
Current Gain Bandwidth Product	f _T	V _{CE} =-5V, I _C =-10mA, f=100MHz		150		MHz
Output Capacitance	C _{ob}	V _{CB} =-10V, I _E =0, f=1MHz			6	pF
Noise Figure	NF	V _{CE} =-5V, I _C =-200μA, f=1KHz, R _G =2KΩ		2	10	dB

■ CLASSIFICATION OF h_{FE}

RANK	A	B	C
RANGE	110-220	200-450	420-800

TYPICAL CHARACTERISTICS

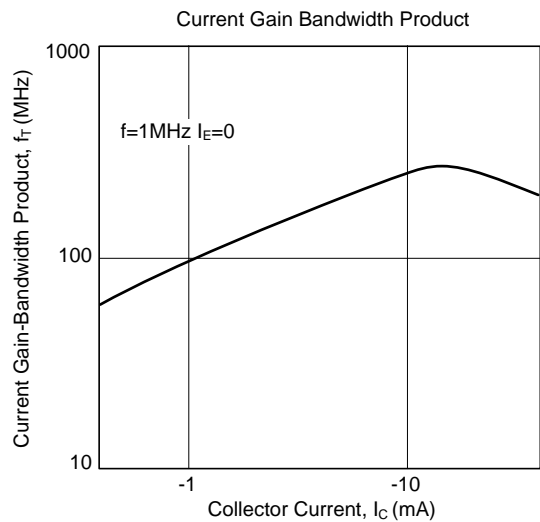
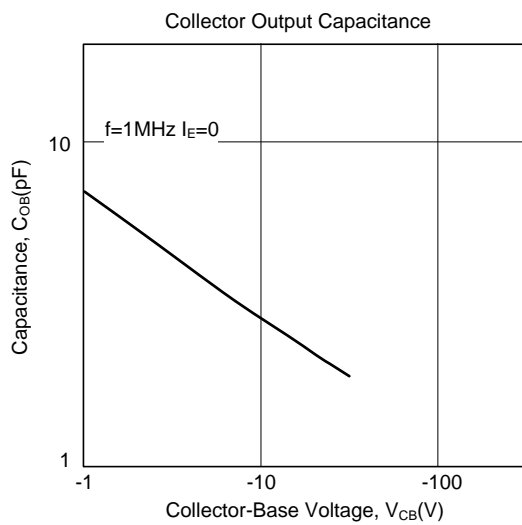
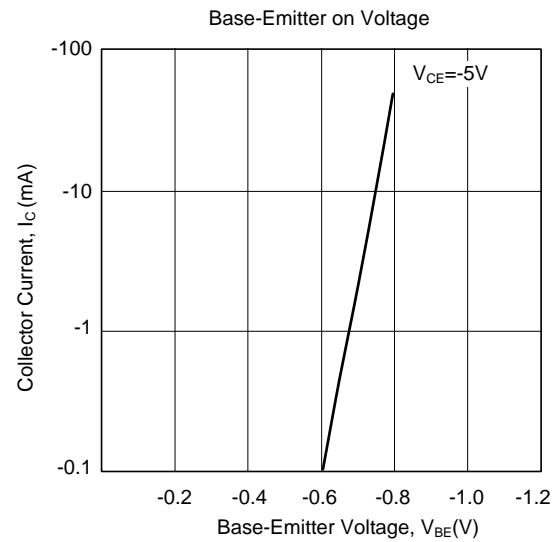
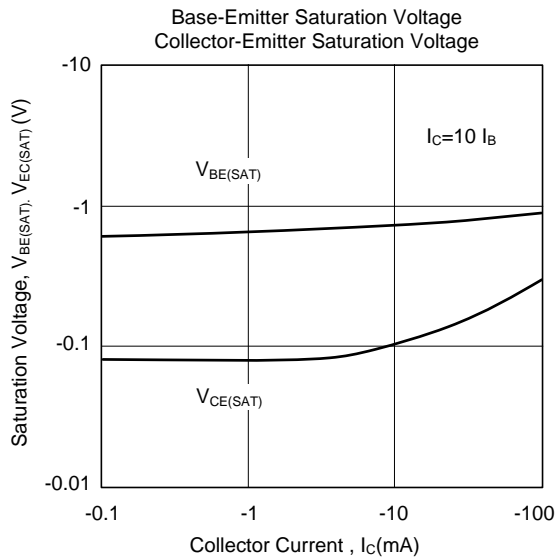
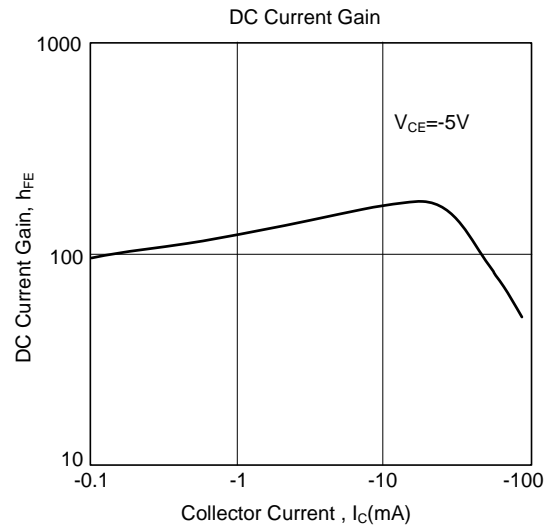
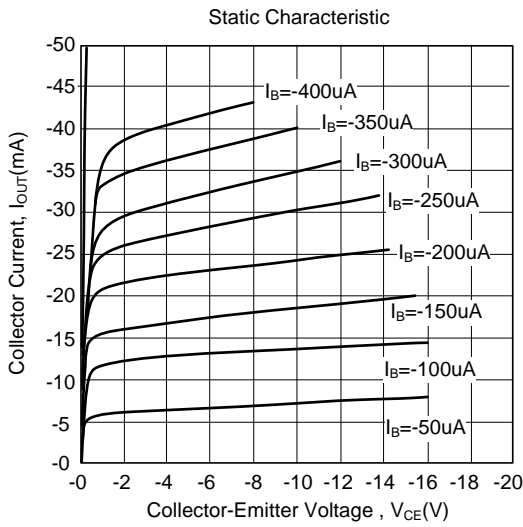

UTC assumes no responsibility for equipment failures that result from using products at values that exceed, even momentarily, rated values (such as maximum ratings, operating condition ranges, or other parameters) listed in products specifications of any and all UTC products described or contained herein. UTC products are not designed for use in life support appliances, devices or systems where malfunction of these products can be reasonably expected to result in personal injury. Reproduction in whole or in part is prohibited without the prior written consent of the copyright owner. The information presented in this document does not form part of any quotation or contract, is believed to be accurate and reliable and may be changed without notice.