



## EIGHT-PORT 10/100 SWITCH WITH ON-CHIP PACKET BUFFER

### FEATURES

- The highest level of silicon integration achieved for a eight-port 10/100 Ethernet switch device
- Fourth generation switch on a chip
- The BCM5328M integrates:
  - Eight transceivers (802.3u compliant)
  - Nine media access controllers (802.x compliant)
  - 256-KB packet buffer
  - Non-blocking switch fabric
- Non-blocking up to 24 ports through a 2.6-Gbps expansion port, cascading up to three devices
- Packet classification 802.1p QoS priority queues
- Port-based VLAN
- MII or 7-wire interface supports an additional 100FX or 100TX connection enabling a sixth user connection or uplink
- Supports up to 4K MAC addresses
- Supports full-duplex (802.3x) and half-duplex options
- Supports automatic address learning and aging
- Internal oscillator circuit
- Typical power consumption: < 1.8W
- 208-pin PQFP package
- Management features:
  - Low-cost MIB Autocast™ function
  - Hardware support for Simple Network Management Protocol (SNMP), Remote Network Monitoring (RMON) and Spanning

### SUMMARY OF BENEFITS

- Enables a new generation of lower cost 10/100 switches in much smaller form factors
- Utilizes field-proven industry-standard 10BASE-T/100BASE-TX Fast Ethernet transceivers—lowering overall system interoperability and reliability risks
- Flexible interfaces support a wider variety of application needs—fiber for long distances or an additional 100TX port
- Sufficient address range handles all remote office, branch office and home office needs
- Port VLAN, trunking, and 802.1p priority enables the switch to be designed into a wide variety of applications
- CPUs are not required to initialize and run in cost-sensitive unmanaged applications—providing true Plug and Play connectivity
- Internal oscillator circuit simplifies design and reduces overall system cost
- Ability to gather and support basic management statistics with only a very low-cost microcontroller
- Low-cost management using the on-chip MIB registers allows the collection and transmission of statistics for each port and provides an upward migration path for corporate users
- On-chip HP auto-MDI/MDIX feature automatically detects and corrects for crossover cables and allows direct switch-to-switch connection

### Low Cost Managed 24-Port 10/100 Smart Switch

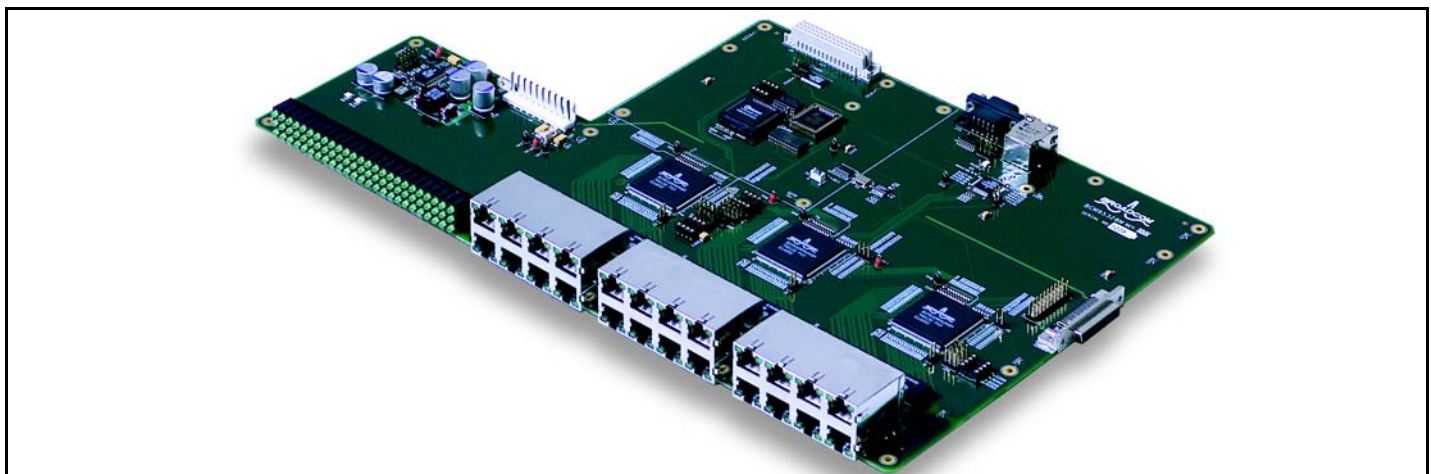

## OVERVIEW

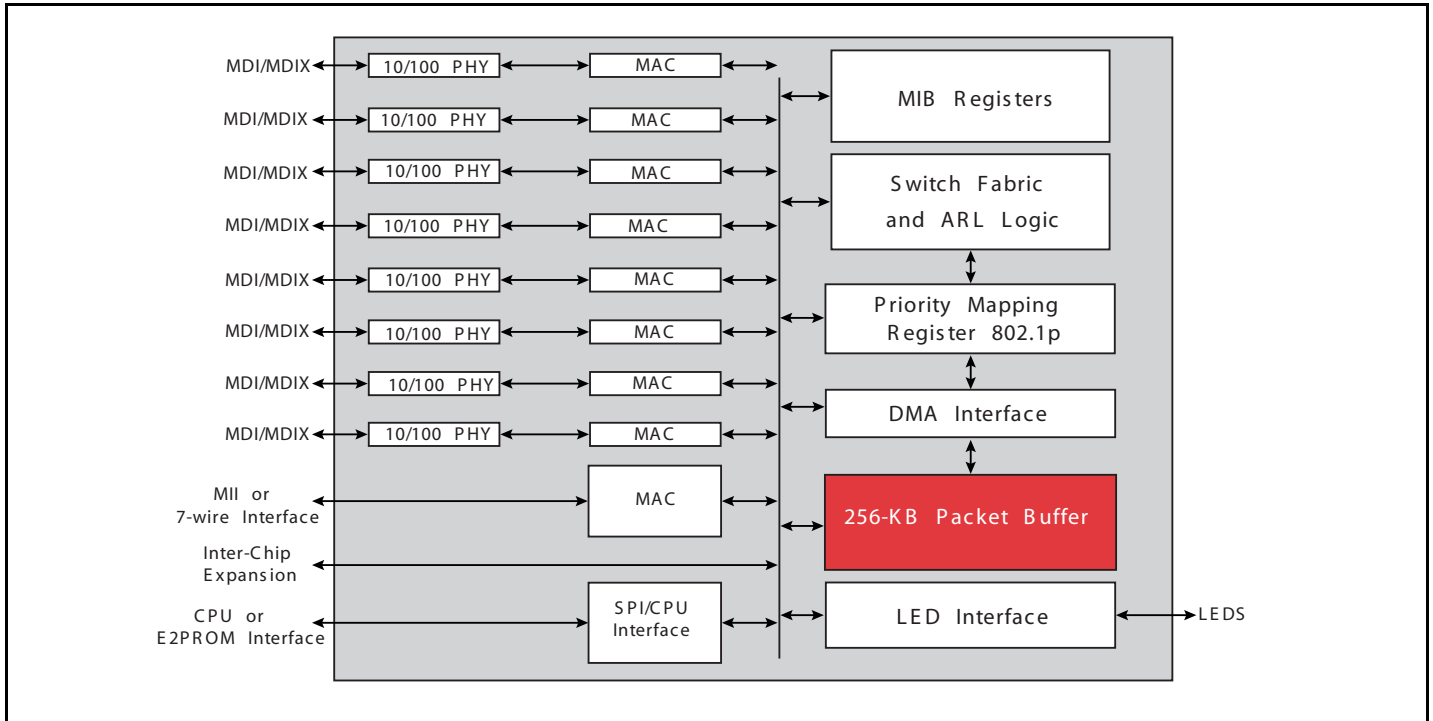

The Broadcom BCM5328M device is a highly integrated solution. It combines all the functions of a high-speed switch system—including packet buffer, PHY transceivers, media access controllers, address management, and a non-blocking switch fabric—into a single 0.18 $\mu$ m CMOS device. It complies with the IEEE 802.3, 802.3u, and 802.3x specifications, including the MAC control PAUSE frame and auto-negotiation subsections, providing compatibility with all industry-standard Ethernet and Fast Ethernet devices.

This device contains eight full-duplex 10BASE-T/100BASE-TX Fast Ethernet transceivers, each of which performs all of the physical layer interface functions for 10BASE-T Ethernet on Category 3, 4, or 5 Unshielded Twisted Pair (UTP) cable and 100BASE-TX Fast Ethernet on Category 5 UTP cable.

SPI or E2PROM interfaces provide easy programming of the 802.1p QoS queues. This allows switch traffic to be given different classes of priority or service, for example, voice traffic for IP phone applications, video traffic for multimedia applications, or data traffic for e-mail applications.

Even though this device is primarily targeted for the cost-sensitive unmanaged market, very low-cost management can also be provided utilizing the proprietary MIB Autocast™ function. MIB Autocast encapsulates the on-chip MIB statistics and sends them out automatically on a predefined port (or ports) at programmed intervals. This feature eliminates the need for a costly CPU and simplifies the management interface.

Using this mode, the BCM5328M periodically transmits a legal Ethernet frame on a designated port. The frames can be intercepted by an external management probe or a dedicated network management application, resident on any node within the network. This function requires only a small, low-cost microcontroller to initialize and configure the device.

The BCM5328M provides an on-chip MIB statistics register to collect, receive, and transmit statistics for each port. Additionally it provides direct hardware support for the EtherLike MIB, Bridge MIB, MIB II (interfaces) and the first four groups of the RMON MIB. All nine groups of RMON can be supported by using additional capabilities, such as port mirroring/snooping, together with an external microcontroller to process some MIB attributes. The MIB registers can be accessed through the serial management port by an external microcontroller.

**Broadcom®**, the pulse logo, **MIB Autocast™**, and **Connecting everything®** are trademarks of Broadcom Corporation and/or its subsidiaries in the United States and certain other countries. All other trademarks mentioned are the property of their respective owners.

Connecting  
**everything®**



**BROADCOM CORPORATION**  
16215 Alton Parkway, P.O. Box 57013  
Irvine, California 92619-7013

© 2004 by BROADCOM CORPORATION. All rights reserved.

5328M-PB05-R 07/13/04

Phone: 949-450-8700  
Fax: 949-450-8710  
E-mail: [info@broadcom.com](mailto:info@broadcom.com)  
Web: [www.broadcom.com](http://www.broadcom.com)