

LIN Transceiver for Automotive

BD41030FJ-C BD41030HFN-C

General Description

BD41030FJ-C, BD41030HFN-C is the best transceiver for BUS system which need LIN (Local Interconnect Network) master and slave protocol. BD41030FJ-C, BD41030HFN-C is low standby electricity consumption in sleep mode.
BD41030FJ-C: SOP-J8
BD41030HFN-C: HSON8

Features

- Compliant with LIN2.0, LIN2.1, LIN2.2, LIN2.2A
 - AEC-Q100 Qualified^(Note 1)
 - Absolute maximum ratings of LIN pin is -27V to +40V
 - Max transmission rate 20kbps
 - Low Electro Magnetic Emission (EME)
 - High Electro Magnetic Immunity (EMI)
 - High impedance at power off for bus
 - Interface (RXD/TXD) with protocol layer corresponds to 3.3V/5.0V logic.
 - Built-in terminator for LIN slave
 - Standby power consumption in sleep mode
 - Transmit data (TXD) dominant time-out function
 - Resistant to LIN-BAT/GND short-circuit
 - Built-in Thermal Shut Down (TSD)
- (Note1: Grade1)

Applications

- LIN communication for Automotive networks.

Key Specifications

- Supply Voltage: 5V to 27V
- Supply Current (Sleep mode): 1μA to 8μA
- Supply Current: (Standby mode; Recessive) 100μA to 1000μA
- Supply Current: (Normal mode; Recessive) 100μA to 1000μA
- Supply Current: (Normal mode; Dominant) 200μA to 2000μA

Package(s)

- SOP-J8
- HSON8

W(Typ) x D(Typ) x H(Max)
4.90mm x 6.00mm x 1.65mm



SOP-J8(BD41030FJ-C)

2.90mm x 3.00mm x 0.60mm



HSON8(BD41030HFN-C)

Typical Application Circuit(s)

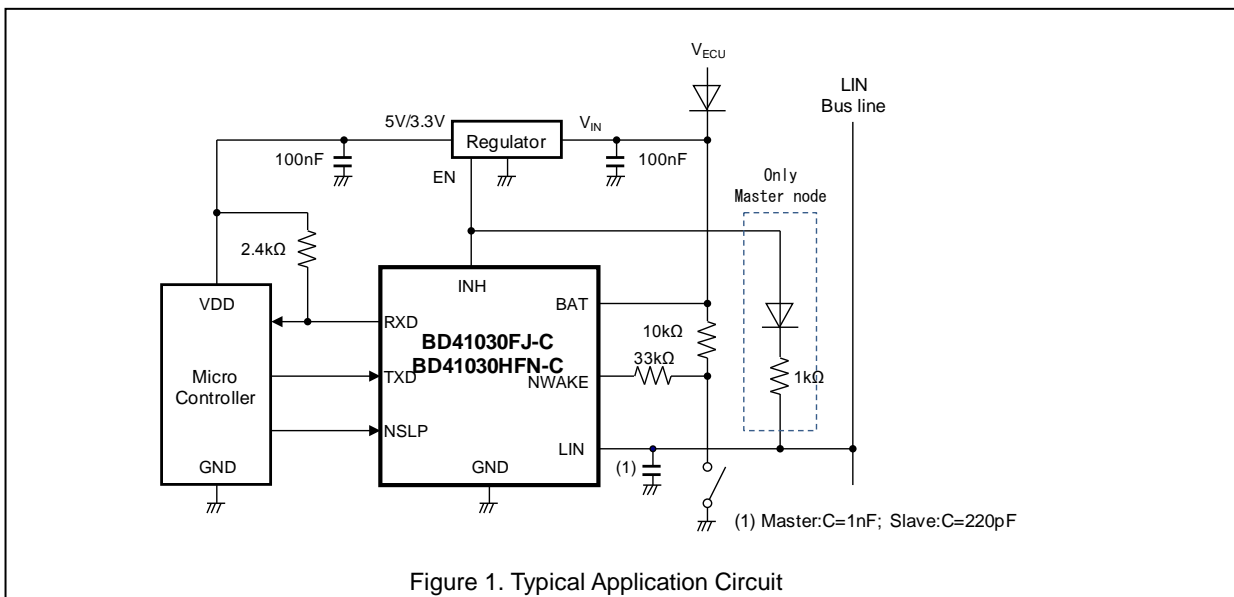

Figure 1. Typical Application Circuit

Contents

General Description	1
Features.....	1
Applications	1
Key Specifications.....	1
Package(s).....	1
Typical Application Circuit(s)	1
Contents	2
Pin Configuration(s)	3
Pin Description(s)	3
Block Diagram(s)	3
Description of Block(s)	4
Absolute Maximum Ratings	6
Recommended Operating Conditions	6
Electrical Characteristics.....	7
Timing Chart	11
Application Example(s)	13
Power Dissipation	14
I/O equivalent circuit(s)	15
Operational Notes	16
Ordering Information	18
Marking Diagrams.....	18
Physical Dimension, Tape and Reel Information.....	19
Revision History	21

Pin Configuration(s)

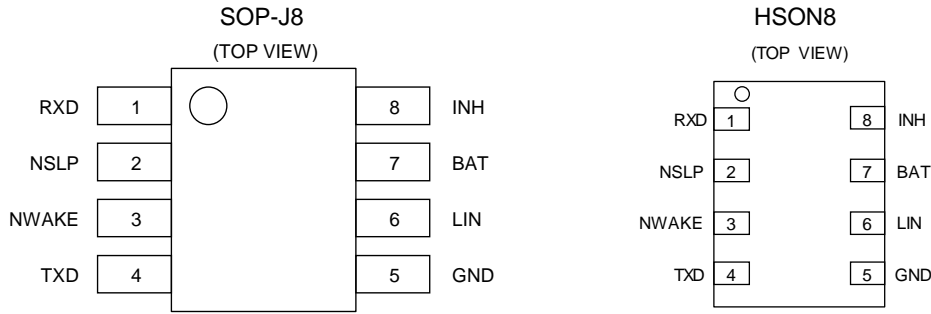

Figure 2. Pin Configuration

Pin Description(s)

Table 1. Pin Description

Pin No.	Pin Name	Function
1	RXD	Received data output pin (Open Drain). “L” is output at standby mode.
2	NSLP	Sleep control input pin (“L” Active mode). Shift to sleep mode by “L” input in normal mode.
3	NWAKE	Local wake-up input pin (“L” Active mode). Active at leading edge.
4	TXD	Transmission data input pin
5	GND	Ground
6	LIN	LIN bus input and output pin.
7	BAT	Power supply pin.
8	INH	Sleep status indicator. “Hi-z” at sleep mode and “H” in the other modes.

Block Diagram(s)

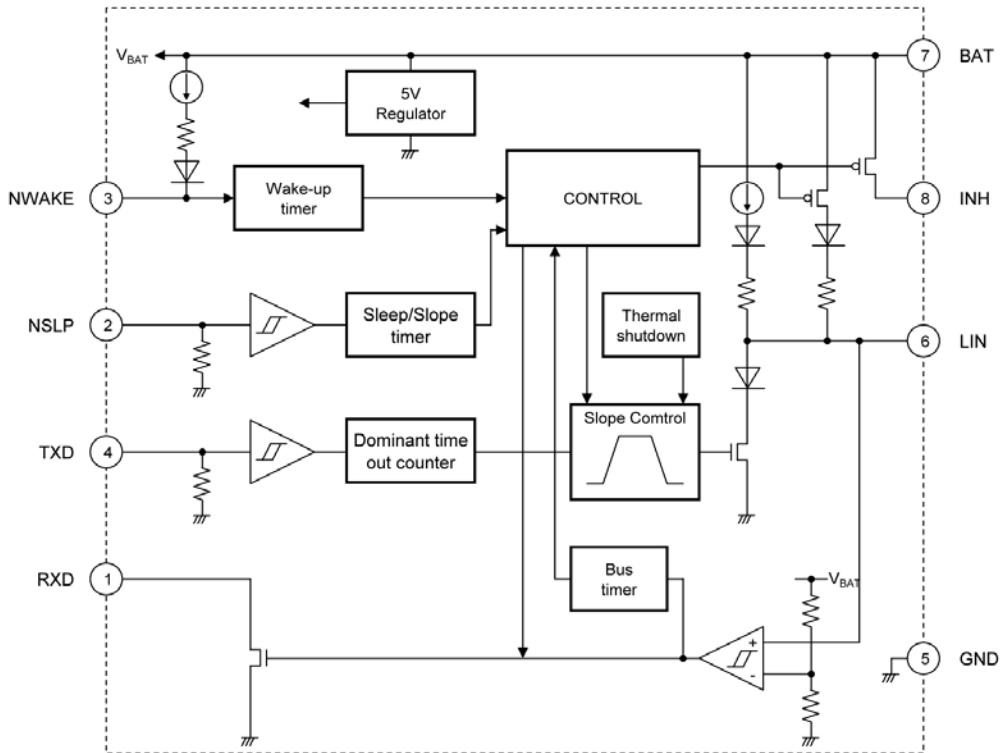

Figure 3. Block diagram

○Product structure : Silicon monolithic integrated circuit ○This product has no designed protection against radioactive rays

Description of Block(s)

1. Sleep mode

In sleep mode, the transmit/receive function is not available and BD41030FJ-C is under the condition of low power consumption mode. In this mode BD41030FJ-C shifts to sleep mode at startup of power supply (V_{BAT}) when NSLP is "L" or in normal mode also when pin NSLP is "L".

During sleep mode, one of the following wake-up events triggers a shift of state:

- Pin NWAKE "H" → "L" (Shift to standby mode)
- Pin LIN "H" → "L" → "H" (Shift to standby mode)
- Pin NSLP "L" → "H" (Shift to normal mode)

The above-mentioned wake-up events shift the mode when a state remains for a given period of time (t_{NWAKE} , t_{BUS} , $t_{gotonorm}$). Hereinafter, a wake-up event on pin NWAKE is defined as Local wake-up, and a wake-up event on pin LIN is defined as Remote wake-up.

2. Standby mode

When a wake-up event occurs on pin NWAKE or pin LIN in sleep mode, BD41030FJ-C shifts to standby mode. In standby mode, pins become the following state:

- Pin INH "H" ($\cong V_{BAT}$ voltage)
- Pin RXD "L" (Informs the microcontroller of being in standby mode.)
- Pin LIN Slave resistor ON

BD41030FJ-C shifts from standby mode to normal mode when pin NSLP input switches to "H".

3. Normal mode

BD41030FJ-C shifts to normal mode when pin NSLP switches to "H" in sleep mode or standby mode. In normal mode, data can be transmitted or received through the bus line. When receiving data, the transceiver informs a LIN bus input from pin RXD to the microcontroller. When transmitting data, the transceiver converts a TXD input signal to a slew-rate-controlled LIN bus signal and informs the bus line of the converted signal. The maximum operating frequency in this mode is 10 kHz.

From this mode, BD41030FJ-C shifts to sleep mode when pin NSLP input switches to "L" and this state remains for a given period of time ($t_{gotosleep}$).

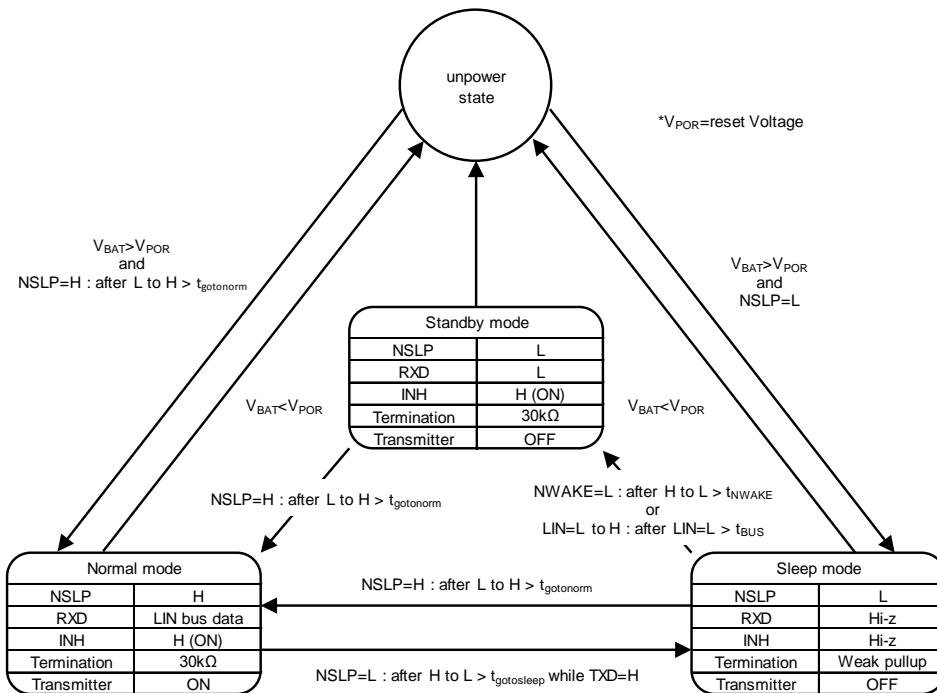

Figure 4. State Transition Chart

Table 2. The state of the pin in each mode

MODE	NSLP	TXD	RXD	INH	TRANSMITTER
Sleep mode	L	pull-down	Hi-z	Hi-z	OFF
Standby mode	L	pull-down	L	H	OFF
Normal mode	H	pull-down	H : recessive state L : dominant state	H	ON

○Product structure : Silicon monolithic integrated circuit ○This product has no designed protection against radioactive rays

4. TXD dominant time-out counters Fail-safe function

A TXD dominant time-out counter prevents the bus line from being driven to a permanent dominant state (blocking all network communication) in case pin TXD input is forced permanently low by a hardware and/or software application failure. The timer is triggered by a negative edge on pin TXD and in case the value exceeds the internal timer value (t_{dom}), the transmitter becomes disabled and drives the bus line into a recessive state. The timer is reset by a positive edge on pin TXD input.

5. Fail-safe function

- Pin TXD provides a pull-down to GND in order to force a predefined level on input pin TXD in case the pin TXD is not connected.
- Pin NSLP provides a pull-down to GND in order to force the transceiver into sleep mode in case the pin NSLP is not connected.
- Pin RXD is "Hi-z" in case of lost power supply on pin V_{BAT} .
- The output driver at pin LIN will be off when junction temperature exceeds T_J activating the TSD circuit without relation to input signal at pin TXD. Because the thermal shut down circuitry has a hysteresis band, junction temperature depends on TXD terminal input signal for the LIN terminal output driver again when 15 degrees Celsius (Typ) degree falls from detective temperature.

Absolute Maximum Ratings (Ta = 25°C)

Table 3. Absolute Maximum Ratings

Parameter	Symbol	Rating	Unit
Supply voltage on pin BAT ^(Note 1)	V _{BAT}	-0.3 to +40.0	V
DC voltage on pin TXD, RXD, NSLP	V _{TXD} , V _{RXD} , V _{NSLP}	-0.3 to +7.0	V
DC voltage on pin LIN	V _{LIN}	-27 to +40	V
DC voltage on pin NWAKE	V _{NWAKE}	-1 to V _{BAT} + 0.3	V
Current on pin NWAKE ^(Note 2)	I _{NWAKE}	-15	mA
DC voltage on pin INH	V _{INH}	-0.3 to V _{BAT} + 0.3	V
Output current at pin INH	I _{INH}	-50 to +15	mA
Power dissipation (SOP-J8) ^(Note 3)	Pd	674	mW
Power dissipation (HSON8) ^(Note 4)	Pd	630	mW
Storage temperature range	T _{stg}	-55 to +150	°C
Junction Max temperature	T _{jmax}	+150	°C
Electro static discharge (HBM) ^(Note 4)	V _{ESD}	4000	V

(Note 1) Pd, ASO should not be exceeded.

(Note 2) Available only when V_{NWAKE} < V_{GND}-0.3V. Current flow to pin GND.

(Note 3) Regarding above Ta=25°C, Pd decreased at 5.40mW/°C for temperatures when mounted on 70x70x1.6mm Glass-epoxy PCB.

(Note 4) Regarding above Ta=25°C, Pd decreased at 5.04mW/°C for temperatures when mounted on 70x70x1.6mm Glass-epoxy PCB.

(Note 5) JEDEC qualified.

Caution: Operating the IC over the absolute maximum ratings may damage the IC. The damage can either be a short circuit between pins or an open circuit between pins and the internal circuitry. Therefore, it is important to consider circuit protection measures, such as adding a fuse, in case the IC is operated over the absolute maximum ratings.

Recommended Operating Conditions

Table 4. Recommended Operating Conditions

Parameter	Symbol	Range	Unit
Supply voltage	V _{BAT}	5.0 to 27.0	V
Operating temperature range	Topr	-40 to +125	°C

Electrical Characteristics (Ta= -40 to +125°C; V_{BAT} =5 to 27V; R_{L(LIN-BAT)} =500Ω; typical values are given at Ta=25°C; V_{BAT} =12V; unless otherwise specified)

Table 5. Electrical Characteristics

Parameter	Symbol	Min	Typ	Max	Unit	Conditions
BAT						
Supply current 1 on pin BAT (Sleep mode)	I _{BAT1}	1	3	8	μA	Sleep mode. V _{LIN} = V _{BAT} V _{NWAKE} = V _{BAT} V _{TXD} = 0V V _{NSLP} = 0V
Supply current 2 on pin BAT (Standby mode, Recessive)	I _{BAT2}	100	400	1000	μA	Standby mode. V _{LIN} = V _{BAT} (bus: Recessive) V _{INH} = V _{BAT} V _{NWAKE} = V _{BAT} V _{TXD} = 0V V _{NSLP} = 0V
Supply current 3 on pin BAT (Note 1) (Standby mode, Dominant)	I _{BAT3}	300	900	2000	μA	Standby mode. V _{BAT} = 12V V _{LIN} = 0V (bus: Dominant) V _{INH} = V _{BAT} V _{NWAKE} = V _{BAT} V _{TXD} = 0V V _{NSLP} = 0V
Supply current 4 on pin BAT (Normal mode, Recessive)	I _{BAT4}	100	400	1000	μA	Normal mode. V _{LIN} = V _{BAT} (bus: Recessive) V _{INH} = V _{BAT} V _{NWAKE} = V _{BAT} V _{TXD} = 5V V _{NSLP} = 5V
Supply current 5 on pin BAT (Note 1) (Normal mode, Dominant)	I _{BAT5}	200	1000	2000	μA	Normal mode. V _{BAT} = 12V (bus: Dominant) V _{INH} = V _{BAT} V _{NWAKE} = V _{BAT} V _{TXD} = 0V V _{NSLP} = 5V
UVLO threshold voltage	V _{UVLO}	-	-	4.9	V	
POR threshold voltage	V _{POR}	-	-	4.3	V	
TXD						
High level input voltage	V _{IH}	2.0	-	7.0	V	
Low level input voltage	V _{IL}	-0.3	-	+0.8	V	
Hysteresis voltage	V _{hys}	0.03	-	0.50	V	
Pull-down resistor	R _{TXD}	125	350	800	kΩ	V _{TXD} = 5V
Low level input current	I _{IL}	-5.0	0.0	+5.0	μA	V _{TXD} = 0V
NSLP						
High level input voltage	V _{IH}	2.0	-	7.0	V	
Low level input voltage	V _{IL}	-0.3	-	+0.8	V	
Hysteresis voltage	V _{hys}	0.03	-	0.50	V	
Pull-down resistor	R _{NSLP}	125	350	800	kΩ	V _{NSLP} = 5V
Low level input current	I _{IL}	-5.0	0.0	+5.0	μA	V _{NSLP} = 0V

(Note 1) When V_{BAT} is 12V or more, add to the circuit current the value calculated by the following expression because I_{BAT} depends on pull-up resistor inside LIN terminal.

$$I_{\text{BAT(increase)}} = \frac{V_{\text{BAT}} - 12\text{V}}{20\text{k}\Omega} \quad (20\text{k}\Omega \text{ is the minimum value of pull-up resistor inside LIN terminal})$$

Electrical Characteristics (Ta= -40 to +125°C; V_{BAT} =5 to 27V; R_{L(LIN-BAT)} =500Ω; typical values are given at Ta=25°C; V_{BAT} =12V; unless otherwise specified)

Table 6. Electrical Characteristics

Parameter	Symbol	Min	Typ	Max	Unit	Conditions
RXD (open-drain)						
Low level output current	I _{OL}	1.3	3.5	-	mA	Normal mode. V _{LIN} = 0V V _{RXD} = 0.4V
High level leakage current	I _{OZH}	-5.0	0.0	+5.0	μA	Normal mode. V _{LIN} = V _{BAT} V _{RXD} = 5V
NWAKE						
High level input voltage	V _{IH}	V _{BAT} - 1.0	-	V _{BAT} + 0.3	V	
Low level input voltage	V _{IL}	-0.3	-	V _{BAT} - 3.3	V	
High level leakage current	I _{IH}	-5.0	0.0	+5.0	μA	V _{NWAKE} = 27V V _{BAT} = 27V
Pull-up current	I _{IL}	-30	-10	-3	μA	V _{NWAKE} = 0V
INH						
Switch-on resistance between pins BAT and INH	R _{INH}	-	30	50	Ω	Standby mode, Normal mode. I _{INH} = -15mA, V _{BAT} = 12V
High level leakage current	I _{OZH}	-5.0	0.0	+5.0	μA	Sleep mode. V _{INH} = V _{BAT} = 27V
LIN						
LIN recessive output voltage	V _{O_rec}	V _{BAT} × 0.9	-	V _{BAT}	V	V _{TXD} = 5V, I _{LIN} = 0mA
LIN dominant output voltage	V _{O_dom1}	-	-	1.2	V	V _{TXD} = 0V, V _{BAT} = 7.3V
	V _{O_dom2}	0.6	-	-	V	V _{TXD} = 0V, V _{BAT} = 7.3V R _{L(LIN-BAT)} = 1kΩ
	V _{O_dom3}	-	-	2.0	V	V _{TXD} = 0V, V _{BAT} = 18V
	V _{O_dom4}	0.8	-	-	V	V _{TXD} = 0V, V _{BAT} = 18V R _{L(LIN-BAT)} = 1kΩ
High level leakage current	I _{IH}	-5.0	0.0	+5.0	μA	V _{LIN} = V _{BAT}
LIN pull-up current	I _{IL}	-10.0	-5.0	-2.0	μA	Sleep mode. V _{LIN} = V _{NSLP} = 0V
Pull-up resistance (Slave termination resistance to pin BAT)	R _{SLAVE}	20	30	47	kΩ	Standby mode, Normal mode. V _{LIN} = 0V, V _{BAT} = 12V
Capacitance of pin LIN (Note 2)	C _{LIN}	-	-	30	pF	
Short-circuit output current	I _{O_SC0}	40	-	200	mA	V _{LIN} = V _{BAT} = 18V, V _{TXD} = 0V t < t _{dom}
Input leakage current at the receiver operating (included pull-up resistor)	I _{BUS_PAS_dom}	-1	-	-	mA	V _{LIN} = 0V V _{BAT} = 12V V _{TXD} = 5V
Input leakage current at the receiver operating	I _{BUS_PAS_rec}	-	-	20	μA	V _{LIN} = 18V V _{BAT} = 8V V _{TXD} = 5V
Loss of ground leakage current	I _{BUS_NO_GND}	-1	-	1	mA	V _{BAT} = V _{GND} = 12V V _{LIN} = 0V to 18V
Loss of battery leakage current	I _{BUS_NO_BAT}	-	-	100	μA	V _{BAT} = 0V V _{LIN} = 18V
Receiver threshold voltage	V _{th_rx}	V _{BAT} × 0.4	-	V _{BAT} × 0.6	V	V _{BAT} = 7.3V to 27.0V
Receiver center voltage (Note 3)	V _{cn_rx}	V _{BAT} × 0.475	V _{BAT} × 0.500	V _{BAT} × 0.525	V	V _{BAT} = 7.3V to 27.0V V _{cn_rx} = (V _{th_dom} + V _{th_rec})/2
Receiver threshold hysteresis voltage (Note 3)	V _{th_hys}	V _{BAT} × 0.100	V _{BAT} × 0.140	V _{BAT} × 0.175	V	V _{BAT} = 7.3V to 27.0V V _{th_hys} = V _{th_rec} - V _{th_dom}

(Note 2) It is a design guarantee parameter, and is not production tested.

Electrical Characteristics (Ta= -40 to +125°C; V_{BAT} =5 to 27V; R_{L(LIN-BAT)} =500Ω; typical values are given at Ta=25°C; V_{BAT} =12V; unless otherwise specified)

Table 7. Electrical Characteristics

Parameter	Symbol	Min	Typ	Max	Unit	Conditions
AC characteristics (Note 7)						
RXD propagation delay	t _{PropRxDom}	-	-	6.0	μs	Normal mode C _{L(LIN-GND)} = 0nF R _{L(LIN-BAT)} = ∞ Voltage on LIN externally forced. LIN t _f , t _r < 20ns C _{RXD} = 20pF R _{RXD} = 2.4kΩ Δt _{d_(BUS-RXD)} = t _{PropRxDom} - t _{PropRxRec}
	t _{PropRxRec}	-	-	6.0	μs	
RXD propagation delay failure	Δt _{d_(BUS-RXD)}	-2.0	0.0	+2.0	μs	
Duty cycle 1 (Note 4, Note 5)	D1	0.396	-	-		Normal mode TH _{Rec(max)} = 0.744 x V _{BAT} TH _{Dom(max)} = 0.581 x V _{BAT} V _{BAT} = 7.0 to 18.0V t _{Bit} = 50μs
Duty cycle 2 (Note 4, Note 6)	D2	-	-	0.581		Normal mode TH _{Rec(min)} = 0.422 x V _{BAT} TH _{Dom(min)} = 0.284 x V _{BAT} V _{BAT} = 7.6 to 18.0V t _{Bit} = 50μs
Duty cycle 3 (Note 4, Note 5)	D3	0.417	-	-		Normal mode TH _{Rec(max)} = 0.778 x V _{BAT} TH _{Dom(max)} = 0.616 x V _{BAT} V _{BAT} = 7.0 to 18.0V t _{Bit} = 96μs
Duty cycle 4 (Note 4, Note 6)	D4	-	-	0.590		Normal mode TH _{Rec(min)} = 0.389 x V _{BAT} TH _{Dom(min)} = 0.251 x V _{BAT} V _{BAT} = 7.6 to 18.0V t _{Bit} = 96μs
Dominant time for wake-up via bus	t _{BUS}	30	70	150	μs	Sleep mode (Remote wake-up)
Dominant time for wake-up via pin NWAKE	t _{NWAKE}	7	20	50	μs	Sleep mode (Local wake-up)
Time period for mode change from sleep or standby mode into normal mode	t _{gotonorm}	2	5	10	μs	Shift from Sleep/Standby mode to Normal mode
Time period for mode change from normal mode into sleep mode	t _{gotosleep}	2	5	10	μs	Shift from Normal mode to Sleep mode
TXD dominant time out	t _{dom}	6	12	20	ms	V _{TXD} = 0V

(Note 3)

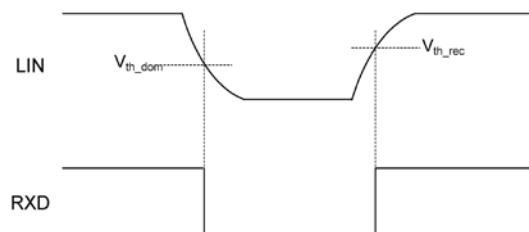
(Note 4) Load condition at bus (C_{L(LIN-GND)}; R_{L(LIN-BAT)}) : 1nF;1kΩ / 6.8nF;660Ω / 10nF;500Ω

(Note 5)

$$D1, D3 = \frac{t_{\text{Bus_rec (min)}}}{2xt_{\text{Bit}}}$$

○Product structure : Silicon monolithic integrated circuit ○This product has no designed protection against radioactive rays

(Note 6)

$$D2, D4 = \frac{t_{\text{Bus_rec(max)}}}{2 \cdot x t_{\text{Bit}}}$$

(Note 7) AC characteristic evaluation circuit diagram

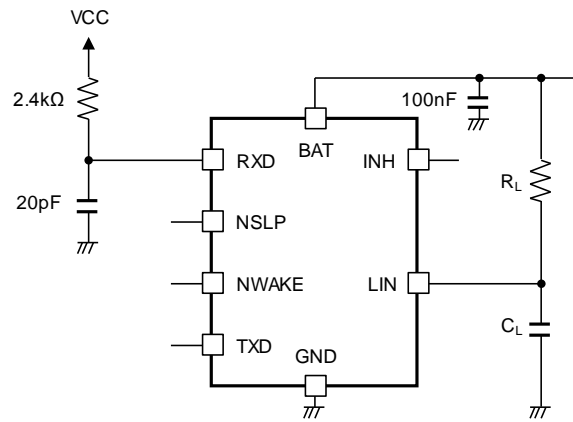

Timing Chart

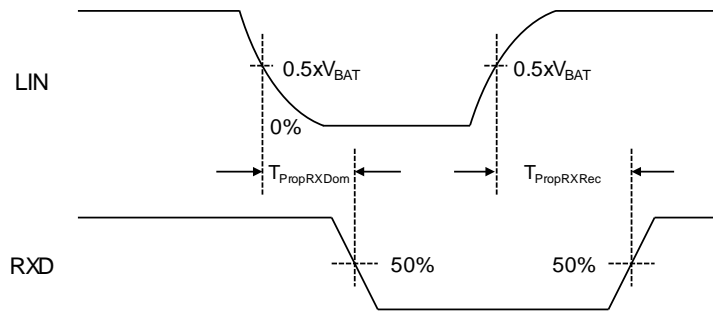

Figure 5. AC characteristic timing chart

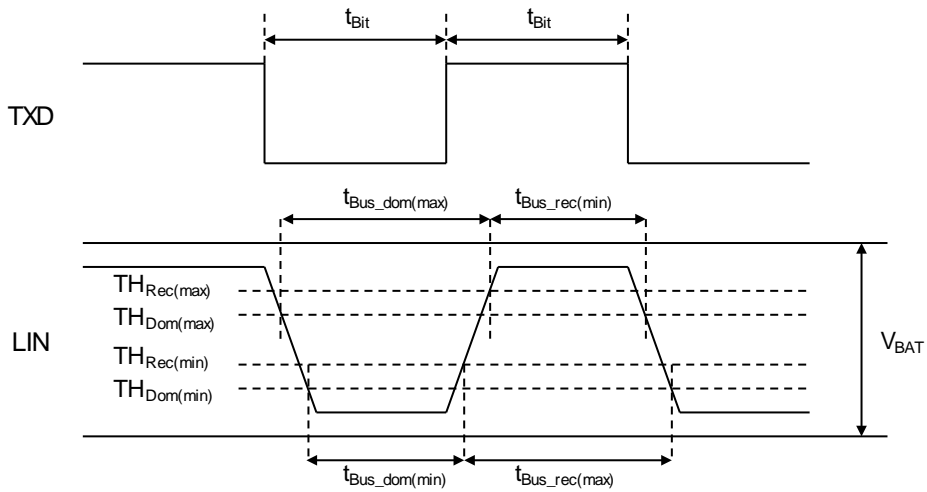

Figure 6. Bus timing chart

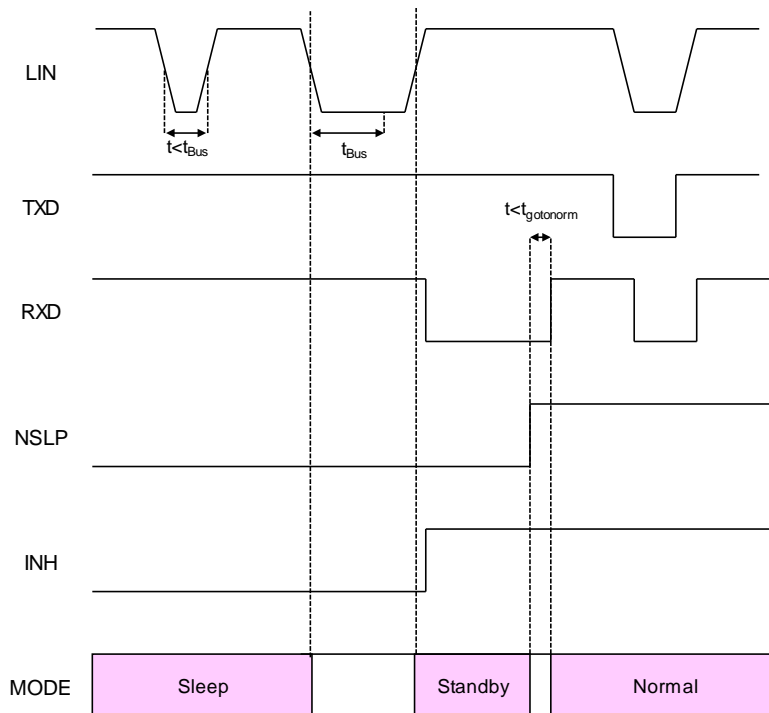

Figure 7. Remote wake-up (Sleep→Standby→Normal)

○Product structure : Silicon monolithic integrated circuit ○This product has no designed protection against radioactive rays

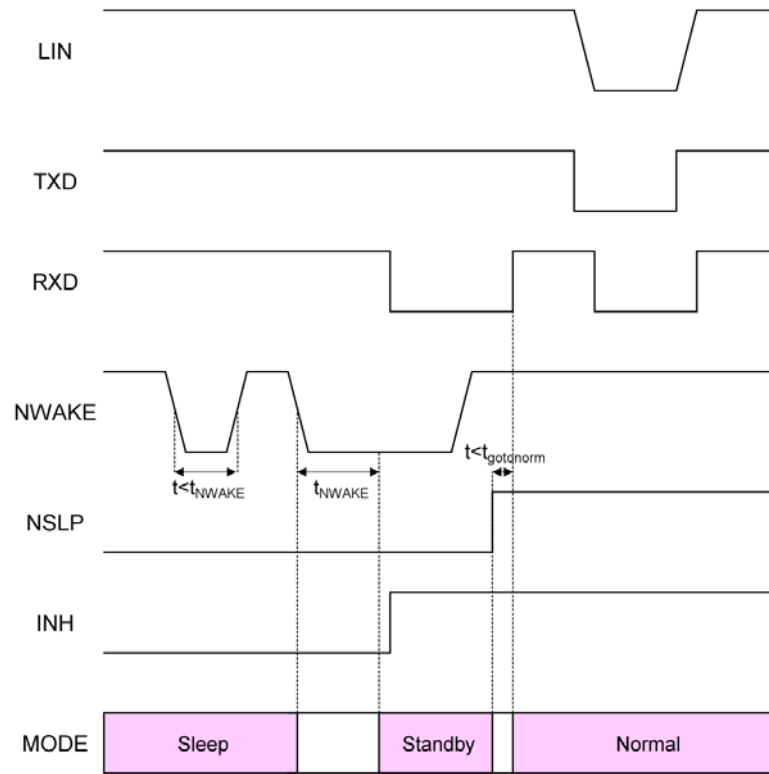

Figure 8. Local wake-up (Sleep→Standby→Normal)

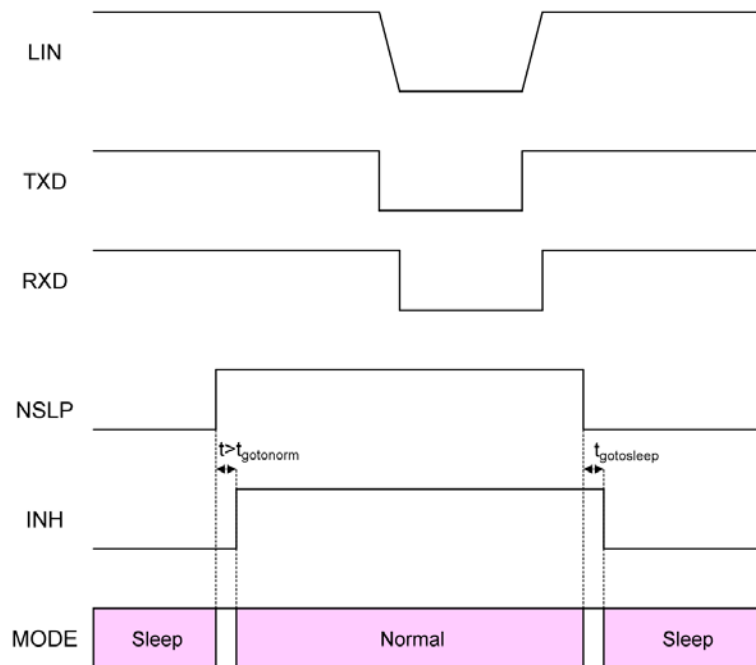

Figure 9. Wake-up/Sleep-in with NSLP (Sleep→Normal→Sleep)

Application Example(s)

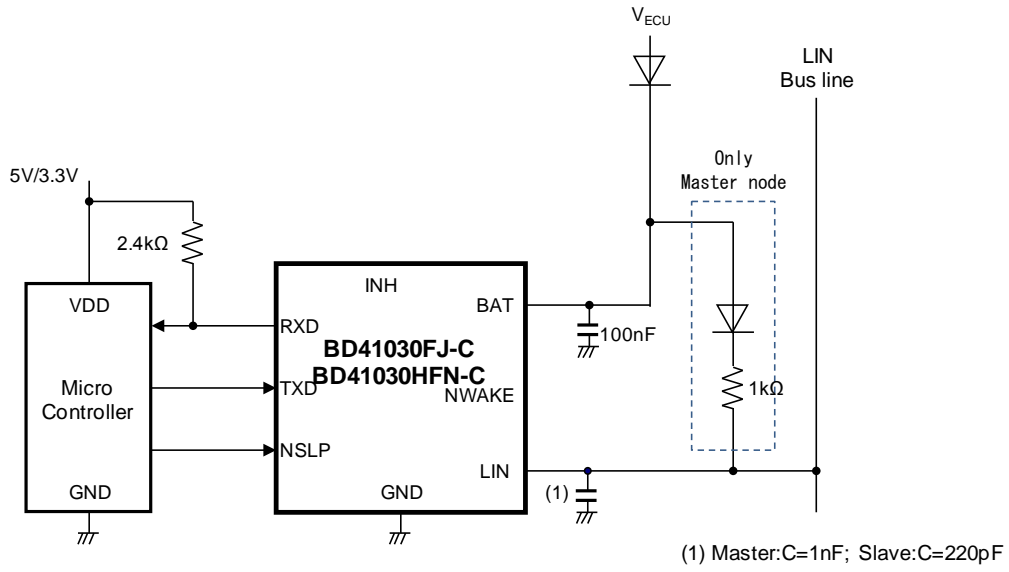
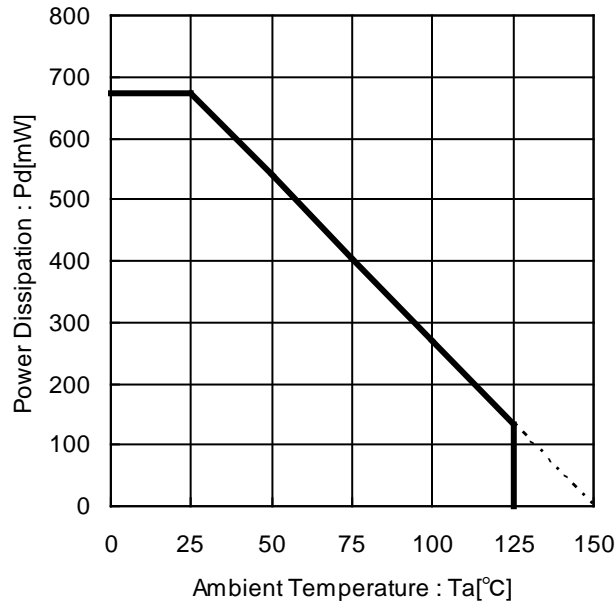

Figure 10. Application Example

Power Dissipation

■ SOP-J8



■ HSON8

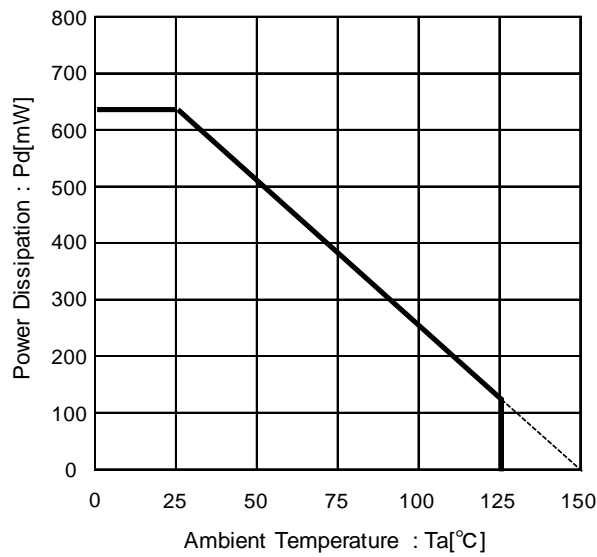

(Note 1) Measured Board (70mm x 70mm x 1.6mm, glass epoxy 1-layer)
 (Note 2) These values are changed by number of layer and copper foil area.

I/O equivalent circuit(s)

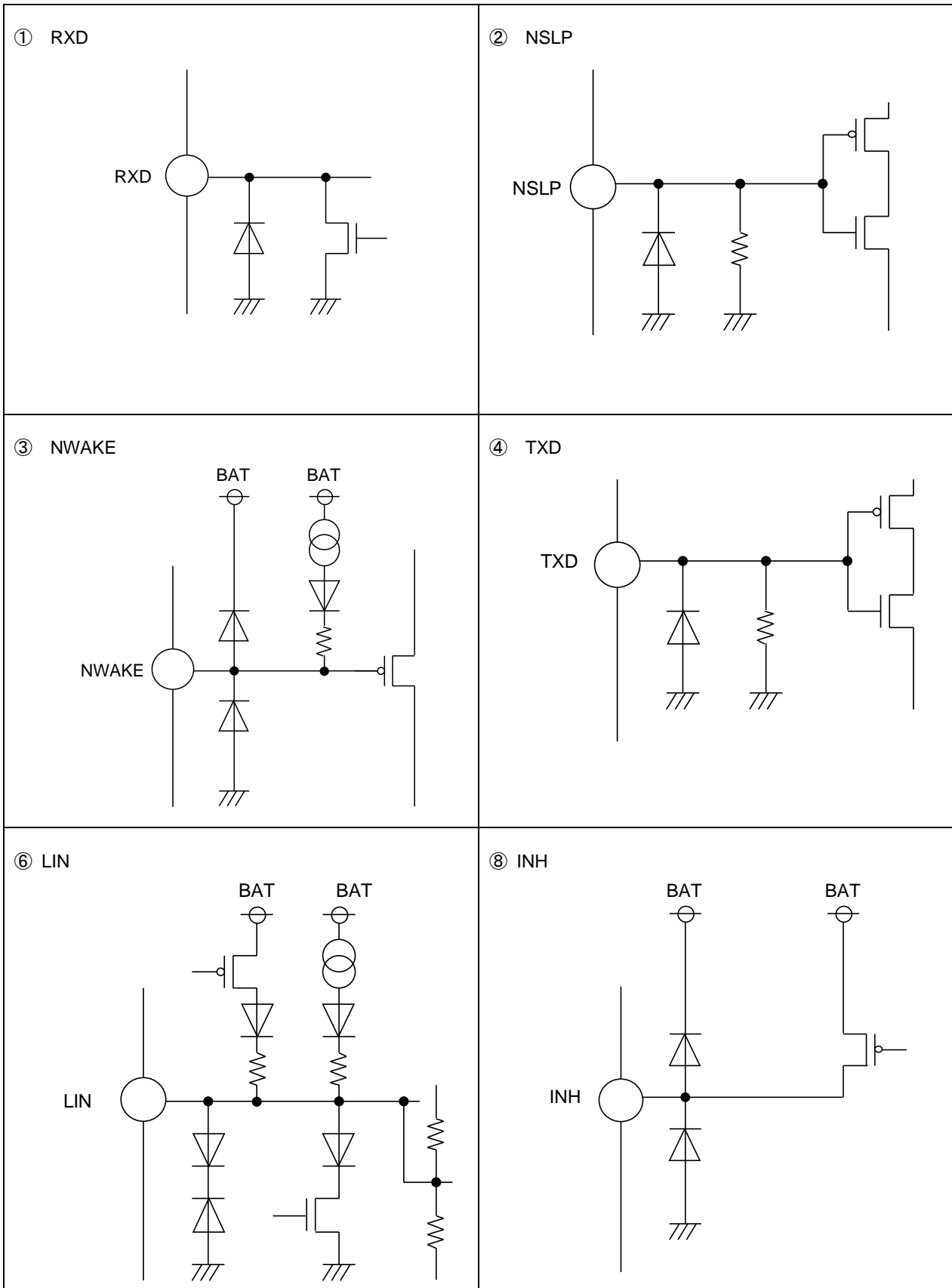

○Product structure : Silicon monolithic integrated circuit ○This product has no designed protection against radioactive rays

Operational Notes

1. Reverse Connection of Power Supply

Connecting the power supply in reverse polarity can damage the IC. Take precautions against reverse polarity when connecting the power supply, such as mounting an external diode between the power supply and the IC's power supply pins.

2. Power Supply Lines

Design the PCB layout pattern to provide low impedance supply lines. Furthermore, connect a capacitor to ground at all power supply pins. Consider the effect of temperature and aging on the capacitance value when using electrolytic capacitors.

3. Ground Voltage

Except for pins the output and the input of which were designed to go below ground, ensure that no pins are at a voltage below that of the ground pin at any time, even during transient condition.

4. Ground Wiring Pattern

When using both small-signal and large-current ground traces, the two ground traces should be routed separately but connected to a single ground at the reference point of the application board to avoid fluctuations in the small-signal ground caused by large currents. Also ensure that the ground traces of external components do not cause variations on the ground voltage. The ground lines must be as short and thick as possible to reduce line impedance.

5. Thermal Consideration

Should by any chance the power dissipation rating be exceeded the rise in temperature of the chip may result in deterioration of the properties of the chip. In case of exceeding this absolute maximum rating, increase the board size and copper area to prevent exceeding the Pd rating.

6. Recommended Operating Conditions

These conditions represent a range within which the expected characteristics of the IC can be approximately obtained. The electrical characteristics are guaranteed under the conditions of each parameter.

7. Inrush Current

When power is first supplied to the IC, it is possible that the internal logic may be unstable and inrush current may flow instantaneously due to the internal powering sequence and delays, especially if the IC has more than one power supply. Therefore, give special consideration to power coupling capacitance, power wiring, width of ground wiring, and routing of connections.

8. Operation Under Strong Electromagnetic Field

Operating the IC in the presence of a strong electromagnetic field may cause the IC to malfunction.

9. Testing on Application Boards

When testing the IC on an application board, connecting a capacitor directly to a low-impedance output pin may subject the IC to stress. Always discharge capacitors completely after each process or step. The IC's power supply should always be turned off completely before connecting or removing it from the test setup during the inspection process. To prevent damage from static discharge, ground the IC during assembly and use similar precautions during transport and storage.

10. Inter-pin Short and Mounting Errors

Ensure that the direction and position are correct when mounting the IC on the PCB. Incorrect mounting may result in damaging the IC. Avoid nearby pins being shorted to each other especially to ground, power supply and output pin. Inter-pin shorts could be due to many reasons such as metal particles, water droplets (in very humid environment) and unintentional solder bridge deposited in between pins during assembly to name a few.

11. Unused Input Pins

Input pins of an IC are often connected to the gate of a MOS transistor. The gate has extremely high impedance and extremely low capacitance. If left unconnected, the electric field from the outside can easily charge it. The small charge acquired in this way is enough to produce a significant effect on the conduction through the transistor and cause unexpected operation of the IC. So unless otherwise specified, unused input pins should be connected to the power supply or ground line.

Operational Notes – continued

12. Regarding the Input Pin of the IC

This monolithic IC contains P+ isolation and P substrate layers between adjacent elements in order to keep them isolated. P-N junctions are formed at the intersection of the P layers with the N layers of other elements, creating a parasitic diode or transistor. For example (refer to figure below):

When GND > Pin A and GND > Pin B, the P-N junction operates as a parasitic diode.
 When GND > Pin B, the P-N junction operates as a parasitic transistor.

Parasitic diodes inevitably occur in the structure of the IC. The operation of parasitic diodes can result in mutual interference among circuits, operational faults, or physical damage. Therefore, conditions that cause these diodes to operate, such as applying a voltage lower than the GND voltage to an input pin (and thus to the P substrate) should be avoided.

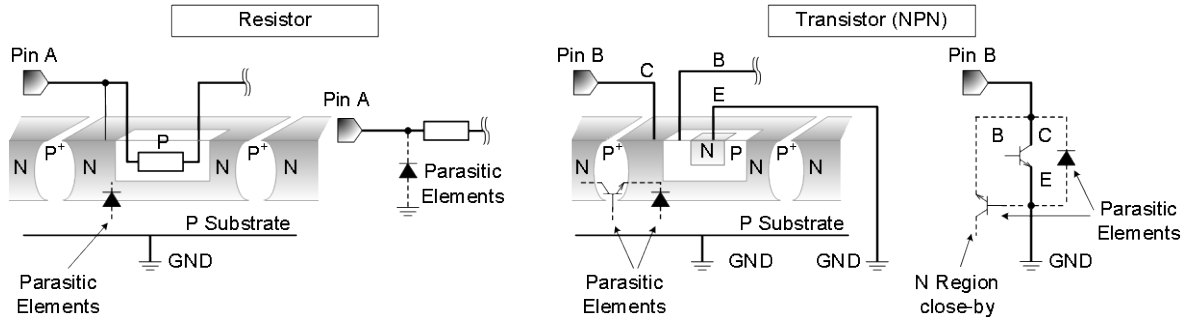

Figure 101. Example of monolithic IC structure

13. Ceramic Capacitor

When using a ceramic capacitor, determine the dielectric constant considering the change of capacitance with temperature and the decrease in nominal capacitance due to DC bias and others.

14. Area of Safe Operation (ASO)

Operate the IC such that the output voltage, output current, and power dissipation are all within the Area of Safe Operation (ASO).

15. Thermal Shutdown Circuit(TSD)

This IC has a built-in thermal shutdown circuit that prevents heat damage to the IC. Normal operation should always be within the IC's power dissipation rating. If however the rating is exceeded for a continued period, the junction temperature (T_j) will rise which will activate the TSD circuit that will turn OFF all output pins. When the T_j falls below the TSD threshold, the circuits are automatically restored to normal operation.

Note that the TSD circuit operates in a situation that exceeds the absolute maximum ratings and therefore, under no circumstances, should the TSD circuit be used in a set design or for any purpose other than protecting the IC from heat damage.

Ordering Information

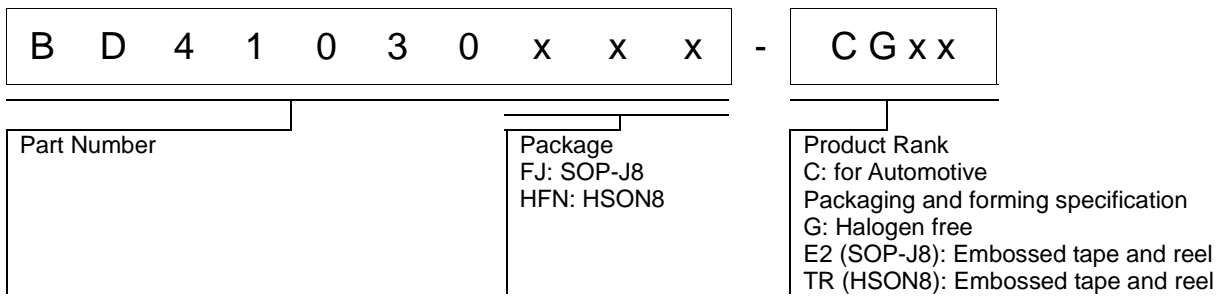

Marking Diagrams

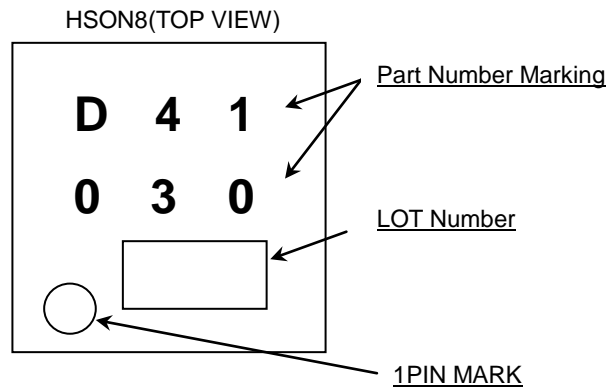
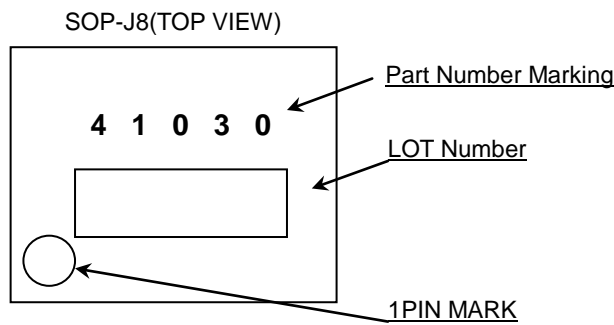

Physical Dimension, Tape and Reel Information

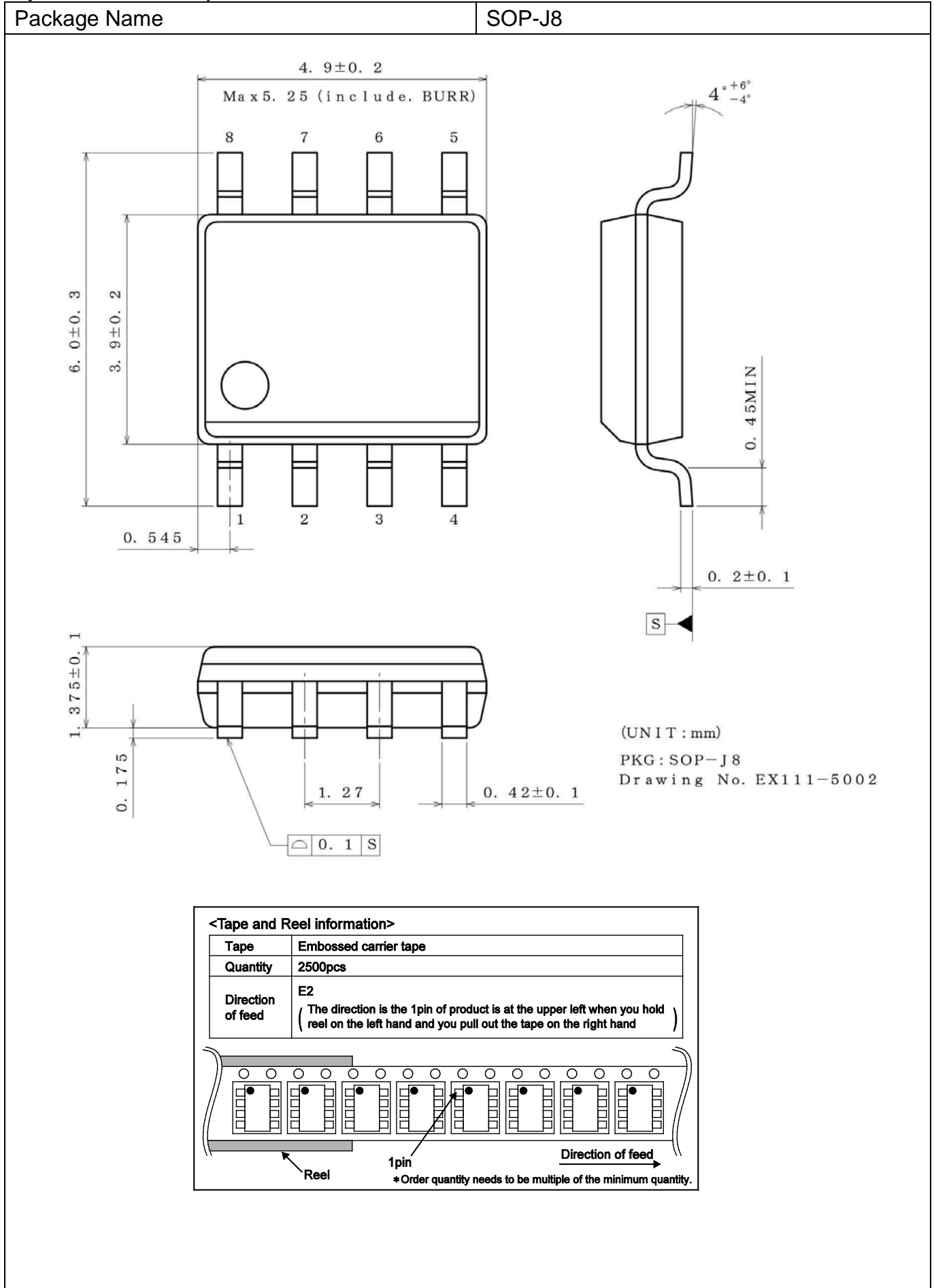

○Product structure : Silicon monolithic integrated circuit ○This product has no designed protection against radioactive rays

Physical Dimension, Tape and Reel Information

Package Name	HSO8
--------------	------

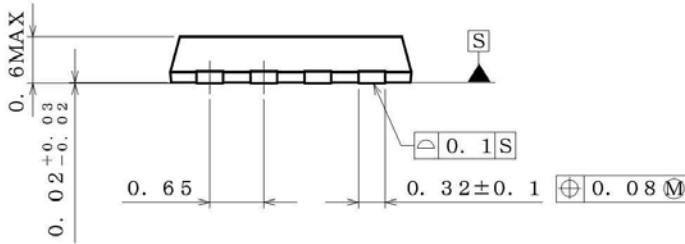
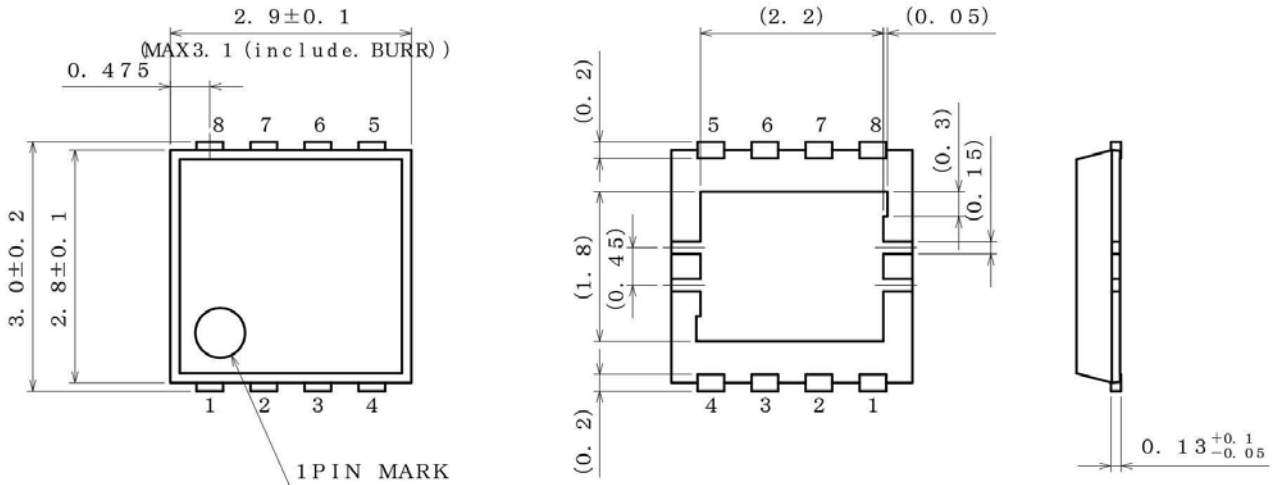

(UNIT : mm)
 PKG : HSO8
 Drawing No. EX163-5002

<Tape and Reel information>

Tape	Embossed carrier tape
Quantity	3000pcs
Direction of feed	TR (The direction is the 1pin of product is at the upper right when you hold reel on the left hand and you pull out the tape on the right hand)

*Order quantity needs to be multiple of the minimum quantity.

○Product structure : Silicon monolithic integrated circuit ○This product has no designed protection against radioactive rays

Revision History

Date	Revision	Changes
12.Jun.2015	001	New Release
18.Aug.2016	002	<ul style="list-style-type: none"> • HSON8 Full-scale revision by the package lineup addition • Typical Performance Curves deletion • P1 Modified Typical Application Circuit • P3 Modified Pin Description • P3 Modified Block diagram • P4 Modified State Transition Chart • P5 Modified Fail-safe function • P6 Absolute Maximum Ratings Modified DC voltage on pin NWAKE • P7 Electrical Characteristics Added 「UVLO threshold voltage」 「POR threshold voltage」 • P8 Electrical Characteristics Modified 「Capacitance of pin LIN」 • P13 Modified Application Example • P14 Modified Power Dissipation • P15 Modified I/O equivalent circuit(s)

Notice

Precaution on using ROHM Products

- If you intend to use our Products in devices requiring extremely high reliability (such as medical equipment ^(Note 1), aircraft/spacecraft, nuclear power controllers, etc.) and whose malfunction or failure may cause loss of human life, bodily injury or serious damage to property ("Specific Applications"), please consult with the ROHM sales representative in advance. Unless otherwise agreed in writing by ROHM in advance, ROHM shall not be in any way responsible or liable for any damages, expenses or losses incurred by you or third parties arising from the use of any ROHM's Products for Specific Applications.

(Note1) Medical Equipment Classification of the Specific Applications

JAPAN	USA	EU	CHINA
CLASS III	CLASS III	CLASS II b	CLASS III
CLASS IV		CLASS III	

- ROHM designs and manufactures its Products subject to strict quality control system. However, semiconductor products can fail or malfunction at a certain rate. Please be sure to implement, at your own responsibilities, adequate safety measures including but not limited to fail-safe design against the physical injury, damage to any property, which a failure or malfunction of our Products may cause. The following are examples of safety measures:
 - Installation of protection circuits or other protective devices to improve system safety
 - Installation of redundant circuits to reduce the impact of single or multiple circuit failure
- Our Products are not designed under any special or extraordinary environments or conditions, as exemplified below. Accordingly, ROHM shall not be in any way responsible or liable for any damages, expenses or losses arising from the use of any ROHM's Products under any special or extraordinary environments or conditions. If you intend to use our Products under any special or extraordinary environments or conditions (as exemplified below), your independent verification and confirmation of product performance, reliability, etc. prior to use, must be necessary:
 - Use of our Products in any types of liquid, including water, oils, chemicals, and organic solvents
 - Use of our Products outdoors or in places where the Products are exposed to direct sunlight or dust
 - Use of our Products in places where the Products are exposed to sea wind or corrosive gases, including Cl₂, H₂S, NH₃, SO₂, and NO₂
 - Use of our Products in places where the Products are exposed to static electricity or electromagnetic waves
 - Use of our Products in proximity to heat-producing components, plastic cords, or other flammable items
 - Sealing or coating our Products with resin or other coating materials
 - Use of our Products without cleaning residue of flux (even if you use no-clean type fluxes, cleaning residue of flux is recommended); or Washing our Products by using water or water-soluble cleaning agents for cleaning residue after soldering
 - Use of the Products in places subject to dew condensation
- The Products are not subject to radiation-proof design.
- Please verify and confirm characteristics of the final or mounted products in using the Products.
- In particular, if a transient load (a large amount of load applied in a short period of time, such as pulse. is applied, confirmation of performance characteristics after on-board mounting is strongly recommended. Avoid applying power exceeding normal rated power; exceeding the power rating under steady-state loading condition may negatively affect product performance and reliability.
- De-rate Power Dissipation depending on ambient temperature. When used in sealed area, confirm that it is the use in the range that does not exceed the maximum junction temperature.
- Confirm that operation temperature is within the specified range described in the product specification.
- ROHM shall not be in any way responsible or liable for failure induced under deviant condition from what is defined in this document.

Precaution for Mounting / Circuit board design

- When a highly active halogenous (chlorine, bromine, etc.) flux is used, the residue of flux may negatively affect product performance and reliability.
- In principle, the reflow soldering method must be used on a surface-mount products, the flow soldering method must be used on a through hole mount products. If the flow soldering method is preferred on a surface-mount products, please consult with the ROHM representative in advance.

For details, please refer to ROHM Mounting specification

Precautions Regarding Application Examples and External Circuits

1. If change is made to the constant of an external circuit, please allow a sufficient margin considering variations of the characteristics of the Products and external components, including transient characteristics, as well as static characteristics.
2. You agree that application notes, reference designs, and associated data and information contained in this document are presented only as guidance for Products use. Therefore, in case you use such information, you are solely responsible for it and you must exercise your own independent verification and judgment in the use of such information contained in this document. ROHM shall not be in any way responsible or liable for any damages, expenses or losses incurred by you or third parties arising from the use of such information.

Precaution for Electrostatic

This Product is electrostatic sensitive product, which may be damaged due to electrostatic discharge. Please take proper caution in your manufacturing process and storage so that voltage exceeding the Products maximum rating will not be applied to Products. Please take special care under dry condition (e.g. Grounding of human body / equipment / solder iron, isolation from charged objects, setting of ionizer, friction prevention and temperature / humidity control).

Precaution for Storage / Transportation

1. Product performance and soldered connections may deteriorate if the Products are stored in the places where:
 - [a] the Products are exposed to sea winds or corrosive gases, including Cl₂, H₂S, NH₃, SO₂, and NO₂
 - [b] the temperature or humidity exceeds those recommended by ROHM
 - [c] the Products are exposed to direct sunshine or condensation
 - [d] the Products are exposed to high Electrostatic
2. Even under ROHM recommended storage condition, solderability of products out of recommended storage time period may be degraded. It is strongly recommended to confirm solderability before using Products of which storage time is exceeding the recommended storage time period.
3. Store / transport cartons in the correct direction, which is indicated on a carton with a symbol. Otherwise bent leads may occur due to excessive stress applied when dropping of a carton.
4. Use Products within the specified time after opening a humidity barrier bag. Baking is required before using Products of which storage time is exceeding the recommended storage time period.

Precaution for Product Label

A two-dimensional barcode printed on ROHM Products label is for ROHM's internal use only.

Precaution for Disposition

When disposing Products please dispose them properly using an authorized industry waste company.

Precaution for Foreign Exchange and Foreign Trade act

Since concerned goods might be fallen under listed items of export control prescribed by Foreign exchange and Foreign trade act, please consult with ROHM in case of export.

Precaution Regarding Intellectual Property Rights

1. All information and data including but not limited to application example contained in this document is for reference only. ROHM does not warrant that foregoing information or data will not infringe any intellectual property rights or any other rights of any third party regarding such information or data.
2. ROHM shall not have any obligations where the claims, actions or demands arising from the combination of the Products with other articles such as components, circuits, systems or external equipment (including software).
3. No license, expressly or implied, is granted hereby under any intellectual property rights or other rights of ROHM or any third parties with respect to the Products or the information contained in this document. Provided, however, that ROHM will not assert its intellectual property rights or other rights against you or your customers to the extent necessary to manufacture or sell products containing the Products, subject to the terms and conditions herein.

Other Precaution

1. This document may not be reprinted or reproduced, in whole or in part, without prior written consent of ROHM.
2. The Products may not be disassembled, converted, modified, reproduced or otherwise changed without prior written consent of ROHM.
3. In no event shall you use in any way whatsoever the Products and the related technical information contained in the Products or this document for any military purposes, including but not limited to, the development of mass-destruction weapons.
4. The proper names of companies or products described in this document are trademarks or registered trademarks of ROHM, its affiliated companies or third parties.

General Precaution

1. Before you use our Products, you are requested to carefully read this document and fully understand its contents. ROHM shall not be in any way responsible or liable for failure, malfunction or accident arising from the use of any ROHM's Products against warning, caution or note contained in this document.
2. All information contained in this document is current as of the issuing date and subject to change without any prior notice. Before purchasing or using ROHM's Products, please confirm the latest information with a ROHM sales representative.
3. The information contained in this document is provided on an "as is" basis and ROHM does not warrant that all information contained in this document is accurate and/or error-free. ROHM shall not be in any way responsible or liable for any damages, expenses or losses incurred by you or third parties resulting from inaccuracy or errors of or concerning such information.



BD41030FJ-C - Web Page

[Distribution Inventory](#)

Part Number	BD41030FJ-C
Package	SOP-J8
Unit Quantity	2500
Minimum Package Quantity	2500
Packing Type	Taping
Constitution Materials List	inquiry
RoHS	Yes