

STRUCTURE Silicon Monolithic Integrated Circuit  
 PRODUCT SERIES 1ch Motor Driver for Digital Still Camera  
 TYPE **BD6369GUL**  
 FEATURES - Built in 1 Constant-Voltage Drivers

●Absolute maximum ratings (Ta=25°C)

Parameter	Symbol	Limit	Unit
Power supply voltage	VCC	-0.5 to +6.5	V
Motor power supply voltage	VM	-0.5 to +6.5	V
Control input voltage	VIN	-0.5 to VCC+0.5	V
Input voltage for Constant-Voltage setting	VLIM	-0.5 to VM+0.5	V
Power dissipation	Pd	730* <sup>1</sup>	mW
Operating temperature range	Topr	-25 to +85	°C
Junction temperature	Tjmax	150	°C
Storage temperature range	Tstg	-55 to +150	°C
H-bridge output current	Iout	-500 to +500* <sup>2</sup>	mA/ch

\*<sup>1</sup> Reduced by 5.84mW/°C over 25°C, when mounted on a glass epoxy board (50mm × 58mm × 1.75mm; 8 layers)

\*<sup>2</sup> Must not exceed Pd, ASO, or Tjmax of 150°C.

●Operating Conditions (Ta= -25°C to +85°C)

Parameter	Symbol	Min.	Typ.	Max.	Unit
Power supply voltage	VCC	2.5	3.0	5.5	V
Motor power supply voltage	VM	2.5	5.0	5.5	V
Control input voltage	VIN	0	-	VCC	V
Input voltage for Constant-Voltage setting	VLIM	0	-	VM	V
H-bridge output current	Iout	-	-	±400* <sup>3</sup>	mA

\*<sup>3</sup> Must not exceed Pd or ASO.

This product isn't designed for protection against radioactive rays.

Status of this document: The Japanese version of this document is the formal specification. A customer may use this translation version only for a reference to help reading the formal version. If there are any differences in translation version of this document, formal version takes priority.

**●BD6369GUL Electrical Characteristics (Unless otherwise specified Ta=25°C, VCC=3.0V, VM=5.0V)**

Parameter	Symbol	Limit			Unit	Conditions
		Min.	Typ.	Max.		
<b>Overall</b>						
Circuit current during standby operation	ICCST	-	0	10	μA	PS=0V
Circuit current1	ICC	-	0.9	1.4	mA	PS=VCC with no signal
Circuit current2	IM	-	0.4	0.65	mA	PS=VCC, VLIM=5V with no signal
<b>Control input (VIN=INA, INB, SEL, PS)</b>						
High level input voltage	VINH	2.0	-	-	V	
Low level input voltage	VINL	-	-	0.7	V	
High level input current	IINH	15	30	60	μA	VIN=3V
Low level input current	IINL	-1	0	-	μA	VIN=0V
Pull-down resistor	RIN	50	100	200	kΩ	
<b>Constant-voltage Control input</b>						
Input current	IVLIM	-1.5	-0.5	-	uA	VLIM=0V
<b>UVLO</b>						
UVLO voltage	VUVLO	1.6	-	2.4	V	
<b>Constant-voltage Drive block</b>						
Output ON-Resistance	RON	-	0.8	1.2	Ω	Io=±400mA on high and low sides in total
Output H voltage	VOH	1.9X VLIM	2.0X VLIM	2.1X VLIM	V	VLIM=1V, 10Ω load
Turn-on time	ton	-	1.5	5	μs	Io=±150mA, 10Ω load
Turn-off time	toff	-	0.1	2	μs	Io=±150mA, 10Ω load
Rise time	tr	-	2	8	μs	Io=±150mA, 10Ω load
Fall time	tf	-	0.05	1	μs	Io=±150mA, 10Ω load

**○Input-Output table**
**Constant-Voltage Drivers**

	INPUT			OUTPUT	
	SEL	INA	INB	OUTA	OUTB
Logic	L	L	X	Z <sup>*4</sup>	Z <sup>*4</sup>
	L	H	L	H	L
	L	H	H	L	H
	H	L	L	L	L
	H	L	H	L	H
	H	H	L	H	L
	H	H	H	Z <sup>*4</sup>	Z <sup>*4</sup>

H : High, L : Low, X : Don't care

<sup>\*4</sup> Z in Constant-Voltage Drivers is a state that POWER MOS has been turned off with the top and bottom. But feed back resistance (20kΩ : Typ) for output H voltage setting is connected between OUTx and GND.

**• Output voltage control**

Output H voltage VOH [V] = 2.0 × VLIM[V] (Typ.)

VOH [V] = VM[V] (VLIM &gt; VM/2)

●Package Outline

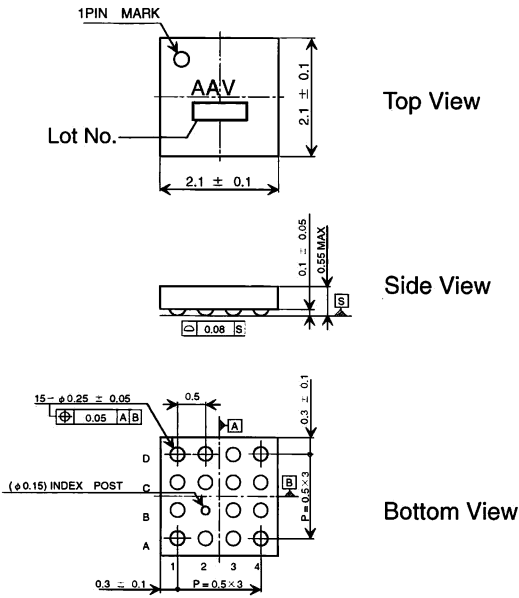

Fig.1 VCSP50L2 Package (Unit: mm)

●Pin Arrangement (Top View)

	1	2	3	4
A	N.C.	OUTA	PS	N.C.
B	VM		INB	INA
C	PGND	VLIM	SEL	VCC
D	N.C.	OUTB	GND	N.C.

Fig.2 BD6369GUL Pin Arrangement (Top View)

●Block Diagram

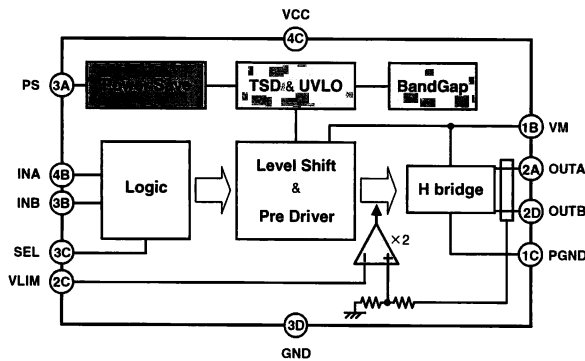
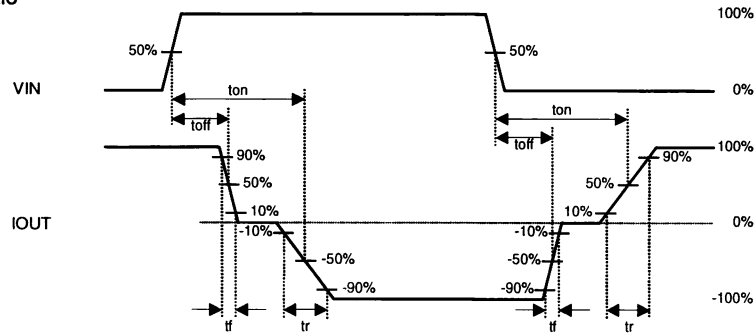

Fig.3 BD6369GUL Block Diagram

●Pin No. and Pin Name

No.	Pin name
1A	N.C.
2A	OUTA
3A	PS
4A	N.C.
1B	VM
2B	
3B	INB
4B	INA
1C	PGND
2C	VLIM
3C	SEL
4C	VCC
1D	N.C.
2D	OUTB
3D	GND
4D	N.C.

●Output AC Characteristic



●Operation Notes

(1) Absolute maximum ratings

Use of the IC in excess of absolute maximum ratings such as the applied voltage or operating temperature range ( $T_{opr}$ ) may result in IC damage. Assumptions should not be made regarding the state of the IC (short mode or open mode) when such damage is suffered. The implementation of a physical safety measure such as a fuse should be considered when use of the IC in a special mode where the absolute maximum ratings may be exceeded is anticipated.

(2) Power supply lines

Regenerated current may flow as a result of the motor's back electromotive force. Insert capacitors between the power supply and ground pins to serve as a route for regenerated current. Determine the capacitance in full consideration of all the characteristics of the electrolytic capacitor, because the electrolytic capacitor may lose some capacitance at low temperatures. If the connected power supply does not have sufficient current absorption capacity, regenerative current will cause the voltage on the power supply line to rise, which combined with the product and its peripheral circuitry may exceed the absolute maximum ratings. It is recommended to implement a physical safety measure such as the insertion of a voltage clamp diode between the power supply and GND pins.

(3) Ground potential

Ensure a minimum GND pin potential in all operating conditions.

(4) Setting of heat

Use a thermal design that allows for a sufficient margin in light of the power dissipation ( $P_d$ ) in actual operating conditions.

(5) Actions in strong magnetic field

Use caution when using the IC in the presence of a strong magnetic field as doing so may cause the IC to malfunction.

(6) ASO

When using the IC, set the output transistor for the motor so that it does not exceed absolute maximum ratings or ASO.

(7) Thermal shutdown circuit

This IC incorporates a TSD (thermal shutdown) circuit (TSD circuit). If the temperature of the chip reaches the following temperature, the motor coil output will be opened. The thermal shutdown circuit (TSD circuit) is designed only to shut the IC off to prevent runaway thermal operation. It is not designed to protect the IC or guarantee its operation. Do not continue to use the IC after operating this circuit or use the IC in an environment where the operation of this circuit is assumed.

TSD ON temperature [°C] (Typ.)	Hysteresis temperature [°C] (Typ.)
175	25

(8) Ground Wiring Pattern

When using both small signal and large current GND patterns, it is recommended to isolate the two ground patterns, placing a single ground point at the application's reference point so that the pattern wiring resistance and voltage variations caused by large currents do not cause variations in the small signal ground voltage. Be careful not to change the GND wiring pattern of any external components, either.

### Notes

- No technical content pages of this document may be reproduced in any form or transmitted by any means without prior permission of ROHM CO.,LTD.
- The contents described herein are subject to change without notice. The specifications for the product described in this document are for reference only. Upon actual use, therefore, please request that specifications to be separately delivered.
- Application circuit diagrams and circuit constants contained herein are shown as examples of standard use and operation. Please pay careful attention to the peripheral conditions when designing circuits and deciding upon circuit constants in the set.
- Any data, including, but not limited to application circuit diagrams information, described herein are intended only as illustrations of such devices and not as the specifications for such devices. ROHM CO.,LTD. disclaims any warranty that any use of such devices shall be free from infringement of any third party's intellectual property rights or other proprietary rights, and further, assumes no liability of whatsoever nature in the event of any such infringement, or arising from or connected with or related to the use of such devices.
- Upon the sale of any such devices, other than for buyer's right to use such devices itself, resell or otherwise dispose of the same, no express or implied right or license to practice or commercially exploit any intellectual property rights or other proprietary rights owned or controlled by
- ROHM CO., LTD. is granted to any such buyer.
- Products listed in this document are no antiradiation design.

The products listed in this document are designed to be used with ordinary electronic equipment or devices (such as audio visual equipment, office-automation equipment, communications devices, electrical appliances and electronic toys).

Should you intend to use these products with equipment or devices which require an extremely high level of reliability and the malfunction of which would directly endanger human life (such as medical instruments, transportation equipment, aerospace machinery, nuclear-reactor controllers, fuel controllers and other safety devices), please be sure to consult with our sales representative in advance.

It is our top priority to supply products with the utmost quality and reliability. However, there is always a chance of failure due to unexpected factors. Therefore, please take into account the derating characteristics and allow for sufficient safety features, such as extra margin, anti-flammability, and fail-safe measures when designing in order to prevent possible accidents that may result in bodily harm or fire caused by component failure. ROHM cannot be held responsible for any damages arising from the use of the products under conditions out of the range of the specifications or due to non-compliance with the NOTES specified in this catalog.

Thank you for your accessing to ROHM product informations.

More detail product informations and catalogs are available, please contact your nearest sales office.

**ROHM** Customer Support System

THE AMERICAS / EUROPE / ASIA / JAPAN

[www.rohm.com](http://www.rohm.com)

Contact us : [webmaster@rohm.co.jp](mailto:webmaster@rohm.co.jp)