

Stepping Motor Driver series

High Performance, High Reliability 36V Stepping Motor Driver

BD6385EFV-LB

Description

This product guarantees long time support in Industrial market.

BD6385EFV are the high-grade type that provides the highest function and highest reliability in the ROHM stepping motor driver. This has the perfect various protection circuits and reduces IC's generation of heat by adopting low-ON resistance DMOS and high heat-radiation power package.

As for its basic function, it is a low power consumption bipolar PWM constant current-drive driver with power supply's rated voltage of 36V and output current 1.0A. For the input interface, the CLK-IN drive mode and the parallel IN drive mode are compatible with each other, so please choose an input mode according to needs of application. There are excitation modes of FULL STEP & HALF STEP (2 kinds), QUARTER STEP mode, and for current decay mode, the ratio of FAST DECAY & SLOW DECAY can be freely set, so the optimum control conditions for every motor can be realized. In addition, being able to drive with one system of power supply makes contribution to the set design's getting easy.

Applications

Industrial Equipment, PPC, multi-function printer, laser beam printer, ink jet printer, monitoring camera, WEB camera, sewing machine, photo printer, FAX, scanner, mini printer, toy, and robot etc.

Key Specification

- Supply voltage : 10V ~ 28V
- Maximum output current : 1.0A
- Operating temperature range : -25°C ~ +75°C
- Output ON resistance : 1.0Ω (Typ.)

Package

HTSSOP-B40

W(Typ.) x D(Typ.) x H(Max.)
13.60mm x 7.80mm x 1.00mm

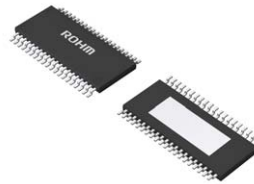

Features

- Long Time Support Product for Industrial Applications.
- Power supply: one system drive (rated voltage of 36V)
- Low ON resistance DMOS output
- CLK-IN drive mode (built-in translator circuit)
- Parallel IN drive mode
- Stepping motor/DC motor (x 2) drives are selectable
- PWM constant current control (self oscillation)
- Built-in spike noise cancel function (external noise filter is unnecessary)
- FULL STEP & HALF STEP (two kinds), applicable to QUARTER STEP
- Applicable to the μSTEP drive
- Current decay mode switching function (linearly variable FAST/SLOW DECAY ratio)
- Normal rotation & reverse rotation switching function
- Power save function
- Built-in logic input pull-down resistor
- Power-on reset function
- Thermal shutdown circuit (TSD)
- Over current protection circuit (OCP)
- Under voltage lock out circuit (UVLO)
- Over voltage lock out circuit (OVLO)
- Malfunction prevention at the time of no applied power supply (Ghost Supply Prevention)
- Adjacent pins short protection
- Inverted mounting protection

Typical Application Circuit

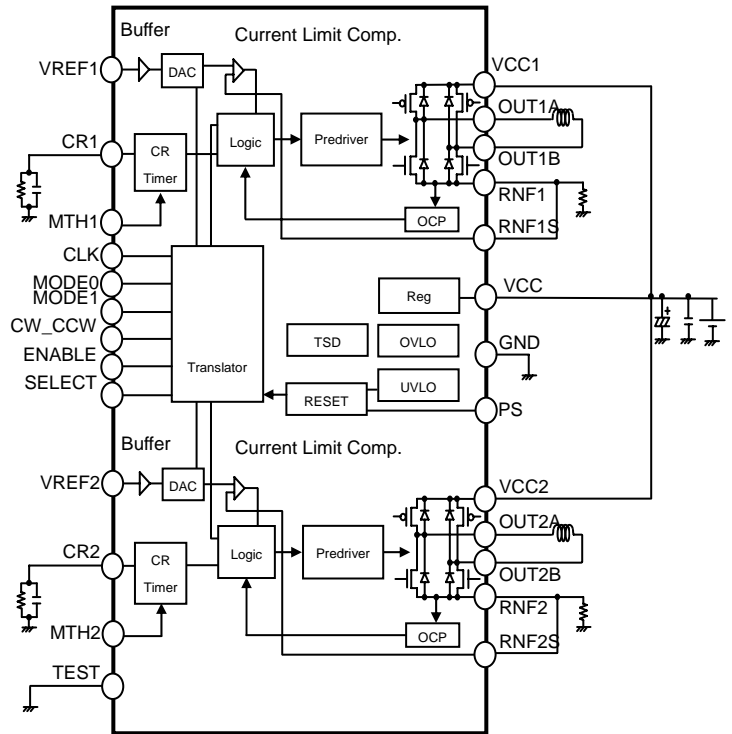

○Product structure : Silicon monolithic integrated circuit ○This product has no designed protection against radioactive rays

Absolute maximum ratings(Ta=25°C)

Item	Symbol	BD6385EFV	Unit
Supply voltage	V _{CC0,1,2}	-0.2~+36.0	V
Power dissipation	Pd	1.6 ^{*1}	W
		4.7 ^{*2}	W
Input voltage for control pin	V _{IN}	-0.2~+5.5	V
RNF maximum voltage	V _{RNF}	0.5	V
Maximum output current	I _{OUT}	1.0 ^{*3}	A/phase
Operating temperature range	T _{opr}	-25~+75	°C
Storage temperature range	T _{stg}	-55~+150	°C
Junction temperature	T _{jmax}	150	°C

*1 70mm × 70mm × 1.6mm glass epoxy board. Derating in done at 12.8mW/°C for operating above Ta=25°C.

*2 4-layer recommended board. Derating in done at 37.6mW/°C for operating above Ta=25°C.

*3 Do not, however exceed Pd, ASO and T_{jmax}=150°C.

Operating conditions(Ta= -25~+75°C)

Item	Symbol	BD6385EFV	Unit
Supply voltage	V _{CC0,1,2}	10~28	V
Output current(DC)	I _{OUT}	0.7 ^{*4}	A/phase

*4 Do not however exceed Pd, ASO.

Electrical characteristics

Applicable to all the series (Unless otherwise specified Ta=25°C, V_{CC0,1,2}=24V)

Item	Symbol	Limit			Unit	Condition
		Min.	Typ.	Max.		
Whole						
Circuit current at standby	I _{CCST}	-	1.0	3.0	mA	PS=L
Circuit current	I _{CC}	-	4.5	10	mA	PS=H, VREFX=2V
Control input (SELECT, CW_CCW, CLK, PS, MODE0, MODE1, ENABLE)						
H level input voltage	V _{INH}	2.0	-	-	V	
L level input voltage	V _{INL}	-	-	0.8	V	
H level input current	I _{INH}	35	50	85	μA	V _{IN} =5V
L level input current	I _{INL}	-10	0	-	μA	V _{IN} =0V
Output (OUT1A, OUT1B, OUT2A, OUT2B)						
Output ON resistance	R _{ON}	-	1.0	1.3	Ω	I _{OUT} = ±1.0A, Sum of upper and lower
Output leak current	I _{LEAK}	-	-	10	μA	
Current control						
RNFXS input current	I _{RNFS}	-2.0	-0.2	-	μA	RNFXS =0V
RNFX input current	I _{RNF}	-40	-20	-	μA	RNFX=0V
VREFX input current	I _{VREF}	-2.0	-0.1	-	μA	VREFX=0V
VREFX input voltage range	V _{REF}	0	-	2.0	V	
MTHX input current	I _{MTH}	-2.0	-0.1	-	μA	MTHX=0V
MTHX input voltage range	V _{MTH}	0	-	3.5	V	
Comparator threshold	V _{CTH}	0.36	0.4	0.44	V	VREFX=2V
Minimum on time	t _{ONMIN}	0.3	0.7	1.2	μs	R=39kΩ, C=1000pF

Terminal function

1) BD6385EFV

Pin No.	Pin name	Function	Pin No.	Pin name	Function
1	NC	Non connection	21	VCC0	Power supply terminal
2	RNF1	Connection terminal of resistor for output current detection	22	NC	Non connection
3	RNF1S	Input terminal of current limit comparator	23	GND	Ground terminal
4	NC	Non connection	24	MODE0	Motor excitation mode setting terminal
5	OUT1B	H bridge output terminal	25	MODE1	Motor excitation mode setting terminal
6	NC	Non connection	26	ENABLE	Output enable terminal
7	OUT1A	H bridge output terminal	27	VREF2	Output current value setting terminal
8	NC	Non connection	28	MTH2	Current decay mode setting terminal
9	VCC1	Power supply terminal	29	NC	Non connection
10	NC	Non connection	30	CR2	Connection terminal of CR for setting PWM frequency
11	CR1	Connection terminal of CR for setting PWM frequency	31	NC	Non connection
12	NC	Non connection	32	VCC2	Power supply terminal
13	MTH1	Current decay mode setting terminal	33	NC	Non connection
14	VREF1	Output current value setting terminal	34	OUT2A	H bridge output terminal
15	SELECT	Input mode select terminal	35	NC	Non connection
16	CW_CCW	Motor rotating direction setting terminal	36	OUT2B	H bridge output terminal
17	NC	Non connection	37	NC	Non connection
18	CLK	Clock input terminal for advancing the electrical angle.	38	RNF2S	Input terminal of current limit comparator
19	PS	Power save terminal	39	RNF2	Connection terminal of resistor for output current detection
20	TEST	Terminal for testing (used by connecting with GND)	40	GND	Ground terminal

Block diagram · Application circuit diagram · Input output equivalent circuit diagram

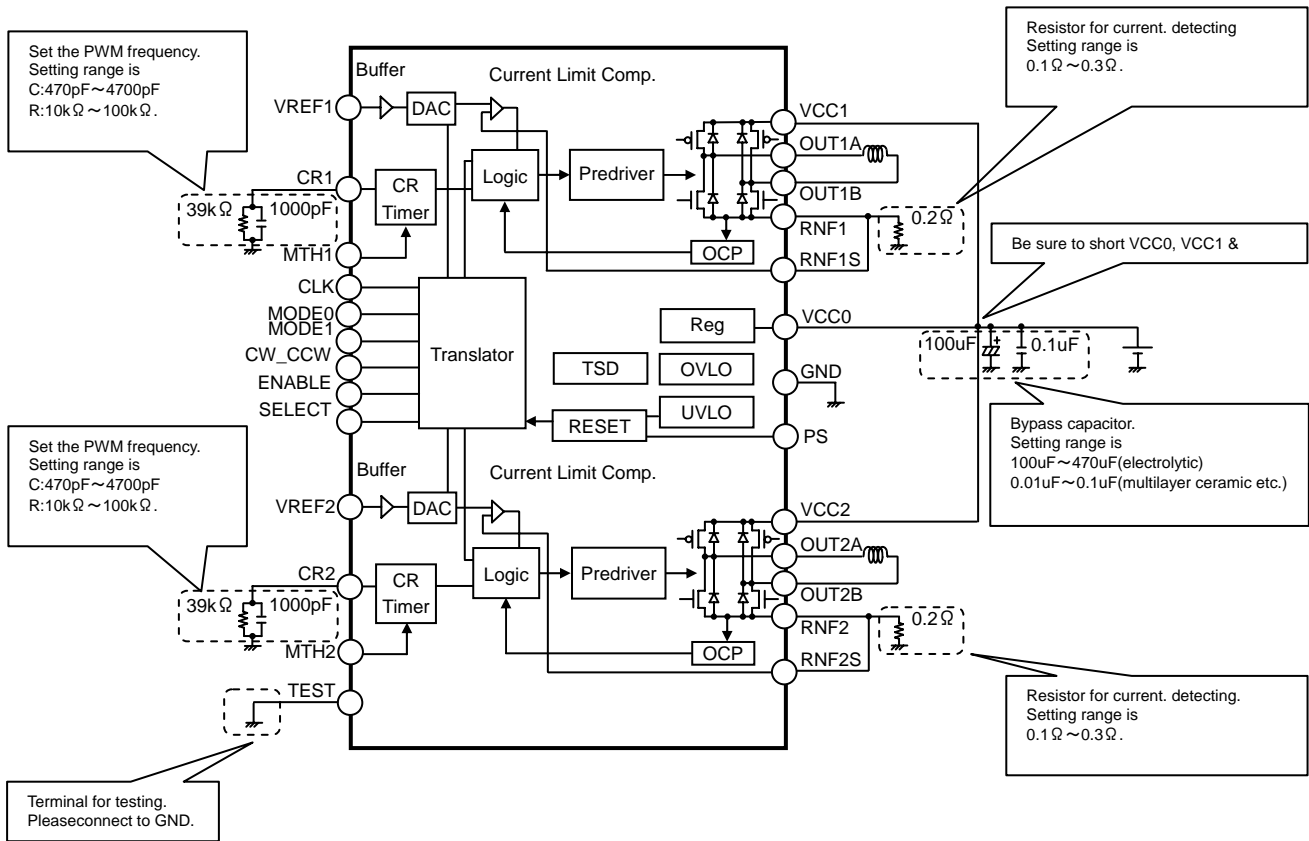

Figure 1. Block diagram & Application circuit diagram of BD6385EFV

Points to notice for terminal description

CLK / Clock input terminal for advancing the electrical angle

CLK is reflected at rising edge. The Electrical angle advances by one for each CLK input.

Motor's misstep will occur if noise is picked up at the CLK terminal, so please design the pattern in such a way that there is no noise plunging.

MODE0,MODE1 / Motor excitation mode setting terminal

Set the motor excitation mode.

MODE0	MODE1	Excitation mode
L	L	FULL STEP
H	L	HALF STEP A
L	H	HALF STEP B
H	H	QUARTER STEP

CW_CCW Terminal / Motor rotating direction setting terminal

Set the motor's rotating direction. Change in setting is reflected at the CLK's rising edge immediately after the change in setting

CW_CCW	Rotating direction
L	Clockwise (CH2's current is outputted with a phase lag of 90° in regard to CH1's current)
H	Counter Clockwise (CH2's current is outputted with a phase lead of 90° in regard to CH1's current)

ENABLE Terminal / Output enable terminal

Turn off forcibly all the output transistors (motor output is open).

At the time of ENABLE=L, electrical angle or operating mode is maintained even if CLK is inputted.

Please be careful because the electrical angle at the time of ENABLE being released (ENABLE=L→H) is different from the released occasion at the section of CLK=H and from the released occasion at the section of CLK=L.

ENABLE	Motor output
L	OPEN (electrical angle maintained)
H	ACTIVE

OPS/Power save terminal

PS can make circuit standby state and make motor output OPEN. In standby state, translator circuit is reset (initialized) and electrical angle is initialized.
 Please be careful because there is a delay of 40μs(max.) before it is returned from standby state to normal state and the motor output becomes ACTIVE.

PS	State
L	Standby state (RESET)
H	ACTIVE

The electrical angle (initial electrical angle) of each excitation mode immediately after RESET is as follows.
 Please be careful because the initial state at the time of FULL STEP is different from those of other excitation modes.

Excitation mode	Initial electrical angle
FULL STEP	45°
HALFSTEP A	0°
HALFSTEP B	0°
QUARTER STEP	0°

OSELECT Terminal/ Input mode switching terminal

This is the terminal to set the input mode.

SELECT	Input mode
L	CLK-IN drive
H	Parallel IN drive

Power dissipation

OHTSSOP-B40 Package

HTSSOP-B40 has exposed metal on the back, and it is possible to dissipate heat from a through hole in the back. Also, the back of board as well as the surfaces has large areas of copper foil heat dissipation patterns, greatly increasing power dissipation. The back metal is shorted with the back side of the IC chip, being a GND potential, therefore there is a possibility for malfunction if it is shorted with any potential other than GND, which should be avoided. Also, it is recommended that the back metal is soldered onto the GND to short. Please note that it has been assumed that this product will be used in the condition of this back metal performed heat dissipation treatment for increasing heat dissipation efficiency.

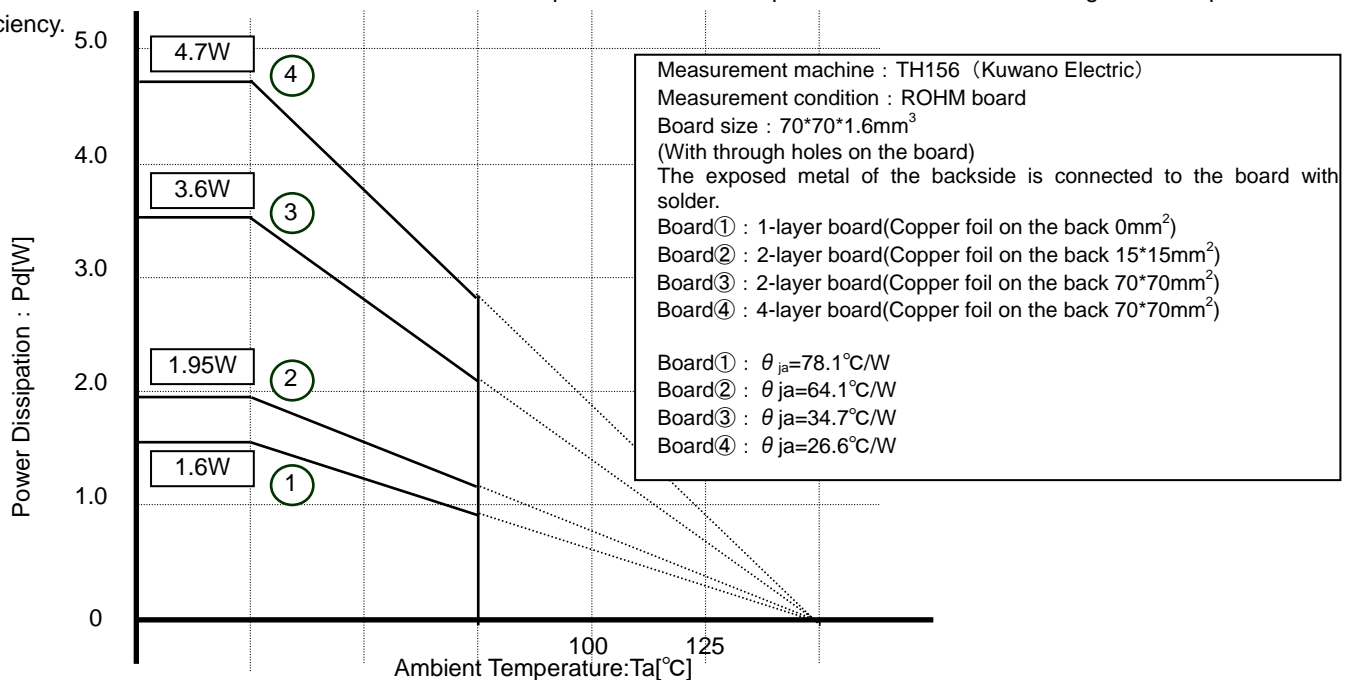

Figure 2. HTSSOP-B40 Derating Curve

Usage Notes

(1) Absolute maximum ratings

An excess in the absolute maximum ratings, such as supply voltage, temperature range of operating conditions, etc., can break down the devices, thus making impossible to identify breaking mode, such as a short circuit or an open circuit. If any over rated values will expect to exceed the absolute maximum ratings, consider adding circuit protection devices, such as fuses.

(2) Connecting the power supply connector backward

Connecting of the power supply in reverse polarity can damage IC. Take precautions when connecting the power supply lines. An external direction diode can be added.

(3) Power supply Lines

Design PCB layout pattern to provide low impedance GND and supply lines. To obtain a low noise ground and supply line, separate the ground section and supply lines of the digital and analog blocks. Furthermore, for all power supply terminals to ICs, connect a capacitor between the power supply and the GND terminal. When applying electrolytic capacitors in the circuit, not that capacitance characteristic values are reduced at low temperatures.

(4) GND Potential

The potential of GND pin must be minimum potential in all operating conditions.

(5) Thermal design

Use a thermal design that allows for a sufficient margin in light of the power dissipation (Pd) in actual operating conditions. Users should be aware that BD6387EFV, BD6385EFV and BD6383EFV have been designed to expose their frames at the back of the package, and should be used with suitable heat dissipation treatment in this area to improve dissipation. As large a dissipation pattern should be taken as possible, not only on the front of the baseboard but also on the back surface. BD6389FM and BD6388FM are both equipped with FIN heat dissipation terminals, but dissipation efficiency can be improved by applying heat dissipation treatment in this area. It is important to consider actual usage conditions and to take as large a dissipation pattern as possible.

(6) Inter-pin shorts and mounting errors

When attaching to a printed circuit board, pay close attention to the direction of the IC and displacement. Improper attachment may lead to destruction of the IC. There is also possibility of destruction from short circuits which can be caused by foreign matter entering between outputs or an output and the power supply or GND.

(7) Operation in a strong electric field

Use caution when using the IC in the presence of a strong electromagnetic field as doing so may cause the IC to malfunction.

(8) ASO

When using the IC, set the output transistor so that it does not exceed absolute maximum ratings or ASO.

(9) Thermal shutdown circuit

The IC has a built-in thermal shutdown circuit (TSD circuit). If the chip temperature becomes $T_{jmax}=150^{\circ}\text{C}$, and higher, coil output to the motor will be open. The TSD circuit is designed only to shut the IC off to prevent runaway thermal operation. It is not designed to protect or indemnify peripheral equipment. Do not use the TSD function to protect peripheral equipment.

TSD on temperature [$^{\circ}\text{C}$] (Typ.)	Hysteresis Temperature [$^{\circ}\text{C}$] (Typ.)
175	25

(10) Inspection of the application board

During inspection of the application board, if a capacitor is connected to a pin with low impedance there is a possibility that it could cause stress to the IC, therefore an electrical discharge should be performed after each process. Also, as a measure against electrostatic discharge, it should be earthed during the assembly process and special care should be taken during transport or storage. Furthermore, when connecting to the jig during the inspection process, the power supply should first be turned off and then removed before the inspection.

(11) Input terminal of IC

This IC is a monolithic IC, and between each element there is a P+ isolation for element partition and a P substrate. This P layer and each element's N layer make up the P-N junction, and various parasitic elements are made up. For example, when the resistance and transistor are connected to the terminal as shown in figure 3,

- When GND > (Terminal A) at the resistance and GND > (Terminal B) at the transistor (NPN), the P-N junction operates as a parasitic diode.
- Also, when GND > (Terminal B) at the transistor (NPN)

The parasitic NPN transistor operates with the N layers of other elements close to the aforementioned parasitic diode.

Because of the IC's structure, the creation of parasitic elements is inevitable from the electrical potential relationship. The operation of parasitic elements causes interference in circuit operation, and can lead to malfunction and destruction. Therefore, be careful not to use it in a way which causes the parasitic elements to operate, such as by applying voltage that is lower than the GND (P substrate) to the input terminal.

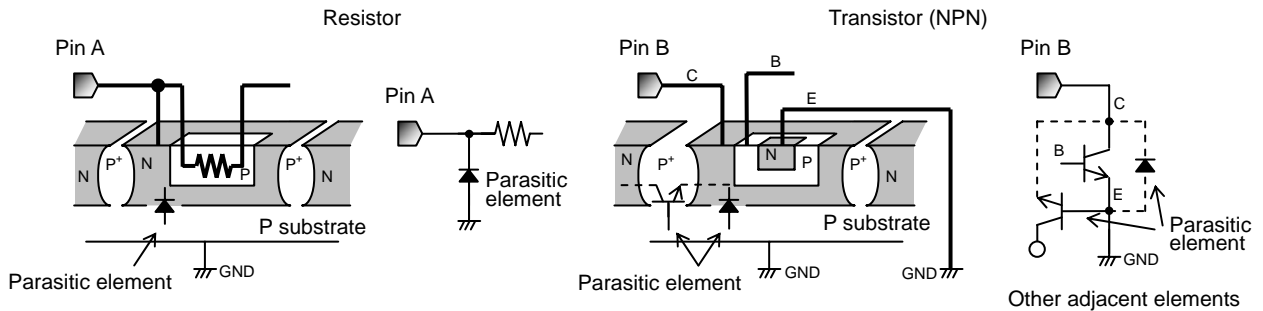

Figure 3. Pattern Diagram of Parasitic Element

(12) Ground Wiring Patterns

When using both small signal and large current GND patterns, it is recommended to isolate the two ground patterns, placing a single ground point at the application's reference point so that the pattern wiring resistance and voltage variations caused by large currents do not cause variations in the small signal ground voltage. Be careful not to change the GND wiring pattern potential of any external components, either.

(13) TEST Terminal

Be sure to connect TEST pin to GND.

Ordering part number

BD6385EFV - LBE2

Product Name	Package EFV : HTSSOP-B40	Product class LB for Industrial applications Packaging and forming specification E2 : Reel-wound embossed taping
--------------	-----------------------------	---

Physical Dimension, Tape and Reel Information

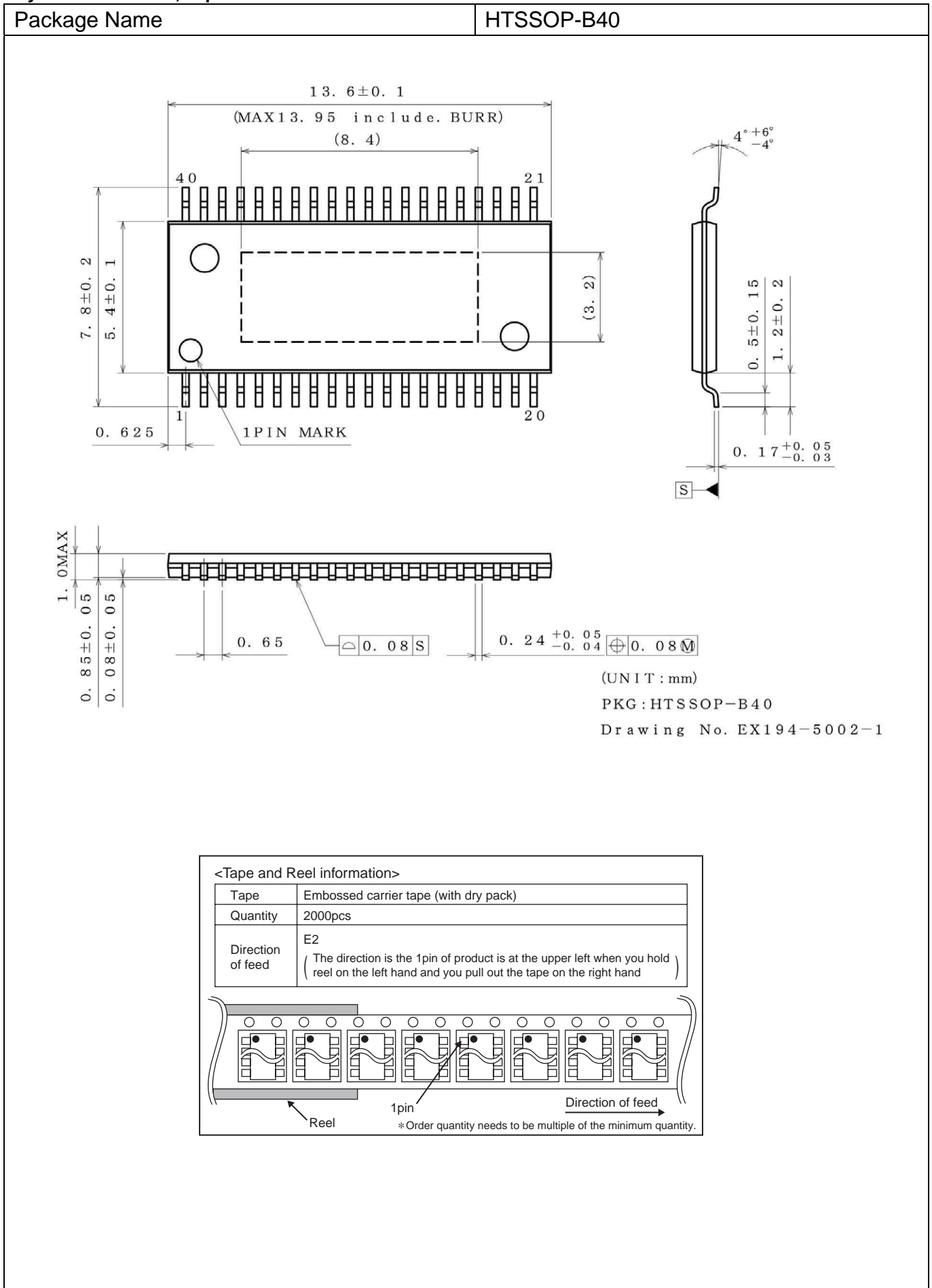

Revision History

Date	Revision	Changes
12.Feb.2013	001	New Release
26.Feb.2014	002	Add sentence "This is the product guarantees long time support in Industrial market." in General Description. Change "Industrial machinery" to "Long Time Support a Product for Industrial Applications." In Features. Change "Industrial machinery" to "Industrial Equipment" in Applications. Applied new style ("title", "Ordering Information" and "Physical Dimension Tape and Reel Information").

Notice

Precaution on using ROHM Products

1. If you intend to use our Products in devices requiring extremely high reliability (such as medical equipment ^(Note 1), aircraft/spacecraft, nuclear power controllers, etc.) and whose malfunction or failure may cause loss of human life, bodily injury or serious damage to property ("Specific Applications"), please consult with the ROHM sales representative in advance. Unless otherwise agreed in writing by ROHM in advance, ROHM shall not be in any way responsible or liable for any damages, expenses or losses incurred by you or third parties arising from the use of any ROHM's Products for Specific Applications.

(Note1) Medical Equipment Classification of the Specific Applications

JAPAN	USA	EU	CHINA
CLASS III	CLASS III	CLASS II b	CLASS III
CLASS IV		CLASS III	

2. ROHM designs and manufactures its Products subject to strict quality control system. However, semiconductor products can fail or malfunction at a certain rate. Please be sure to implement, at your own responsibilities, adequate safety measures including but not limited to fail-safe design against the physical injury, damage to any property, which a failure or malfunction of our Products may cause. The following are examples of safety measures:
 - [a] Installation of protection circuits or other protective devices to improve system safety
 - [b] Installation of redundant circuits to reduce the impact of single or multiple circuit failure
3. Our Products are not designed under any special or extraordinary environments or conditions, as exemplified below. Accordingly, ROHM shall not be in any way responsible or liable for any damages, expenses or losses arising from the use of any ROHM's Products under any special or extraordinary environments or conditions. If you intend to use our Products under any special or extraordinary environments or conditions (as exemplified below), your independent verification and confirmation of product performance, reliability, etc, prior to use, must be necessary:
 - [a] Use of our Products in any types of liquid, including water, oils, chemicals, and organic solvents
 - [b] Use of our Products outdoors or in places where the Products are exposed to direct sunlight or dust
 - [c] Use of our Products in places where the Products are exposed to sea wind or corrosive gases, including Cl₂, H₂S, NH₃, SO₂, and NO₂
 - [d] Use of our Products in places where the Products are exposed to static electricity or electromagnetic waves
 - [e] Use of our Products in proximity to heat-producing components, plastic cords, or other flammable items
 - [f] Sealing or coating our Products with resin or other coating materials
 - [g] Use of our Products without cleaning residue of flux (even if you use no-clean type fluxes, cleaning residue of flux is recommended); or Washing our Products by using water or water-soluble cleaning agents for cleaning residue after soldering
 - [h] Use of the Products in places subject to dew condensation
4. The Products are not subject to radiation-proof design.
5. Please verify and confirm characteristics of the final or mounted products in using the Products.
6. In particular, if a transient load (a large amount of load applied in a short period of time, such as pulse. is applied, confirmation of performance characteristics after on-board mounting is strongly recommended. Avoid applying power exceeding normal rated power; exceeding the power rating under steady-state loading condition may negatively affect product performance and reliability.
7. De-rate Power Dissipation (Pd) depending on Ambient temperature (Ta). When used in sealed area, confirm the actual ambient temperature.
8. Confirm that operation temperature is within the specified range described in the product specification.
9. ROHM shall not be in any way responsible or liable for failure induced under deviant condition from what is defined in this document.

Precaution for Mounting / Circuit board design

1. When a highly active halogenous (chlorine, bromine, etc.) flux is used, the residue of flux may negatively affect product performance and reliability.
2. In principle, the reflow soldering method must be used; if flow soldering method is preferred, please consult with the ROHM representative in advance.

For details, please refer to ROHM Mounting specification

Precautions Regarding Application Examples and External Circuits

1. If change is made to the constant of an external circuit, please allow a sufficient margin considering variations of the characteristics of the Products and external components, including transient characteristics, as well as static characteristics.
2. You agree that application notes, reference designs, and associated data and information contained in this document are presented only as guidance for Products use. Therefore, in case you use such information, you are solely responsible for it and you must exercise your own independent verification and judgment in the use of such information contained in this document. ROHM shall not be in any way responsible or liable for any damages, expenses or losses incurred by you or third parties arising from the use of such information.

Precaution for Electrostatic

This Product is electrostatic sensitive product, which may be damaged due to electrostatic discharge. Please take proper caution in your manufacturing process and storage so that voltage exceeding the Products maximum rating will not be applied to Products. Please take special care under dry condition (e.g. Grounding of human body / equipment / solder iron, isolation from charged objects, setting of ionizer, friction prevention and temperature / humidity control).

Precaution for Storage / Transportation

1. Product performance and soldered connections may deteriorate if the Products are stored in the places where:
 - [a] the Products are exposed to sea winds or corrosive gases, including Cl₂, H₂S, NH₃, SO₂, and NO₂
 - [b] the temperature or humidity exceeds those recommended by ROHM
 - [c] the Products are exposed to direct sunshine or condensation
 - [d] the Products are exposed to high Electrostatic
2. Even under ROHM recommended storage condition, solderability of products out of recommended storage time period may be degraded. It is strongly recommended to confirm solderability before using Products of which storage time is exceeding the recommended storage time period.
3. Store / transport cartons in the correct direction, which is indicated on a carton with a symbol. Otherwise bent leads may occur due to excessive stress applied when dropping of a carton.
4. Use Products within the specified time after opening a humidity barrier bag. Baking is required before using Products of which storage time is exceeding the recommended storage time period.

Precaution for Product Label

QR code printed on ROHM Products label is for ROHM's internal use only.

Precaution for Disposition

When disposing Products please dispose them properly using an authorized industry waste company.

Precaution for Foreign Exchange and Foreign Trade act

Since our Products might fall under controlled goods prescribed by the applicable foreign exchange and foreign trade act, please consult with ROHM representative in case of export.

Precaution Regarding Intellectual Property Rights

1. All information and data including but not limited to application example contained in this document is for reference only. ROHM does not warrant that foregoing information or data will not infringe any intellectual property rights or any other rights of any third party regarding such information or data. ROHM shall not be in any way responsible or liable for infringement of any intellectual property rights or other damages arising from use of such information or data.:
2. No license, expressly or implied, is granted hereby under any intellectual property rights or other rights of ROHM or any third parties with respect to the information contained in this document.

Other Precaution

1. This document may not be reprinted or reproduced, in whole or in part, without prior written consent of ROHM.
2. The Products may not be disassembled, converted, modified, reproduced or otherwise changed without prior written consent of ROHM.
3. In no event shall you use in any way whatsoever the Products and the related technical information contained in the Products or this document for any military purposes, including but not limited to, the development of mass-destruction weapons.
4. The proper names of companies or products described in this document are trademarks or registered trademarks of ROHM, its affiliated companies or third parties.

General Precaution

1. Before you use our Products, you are requested to carefully read this document and fully understand its contents. ROHM shall not be in any way responsible or liable for failure, malfunction or accident arising from the use of any ROHM's Products against warning, caution or note contained in this document.
2. All information contained in this document is current as of the issuing date and subject to change without any prior notice. Before purchasing or using ROHM's Products, please confirm the latest information with a ROHM sales representative.
3. The information contained in this document is provided on an "as is" basis and ROHM does not warrant that all information contained in this document is accurate and/or error-free. ROHM shall not be in any way responsible or liable for any damages, expenses or losses incurred by you or third parties resulting from inaccuracy or errors of or concerning such information.