

Silicon Switching Diodes

- Switching applications
- High breakdown voltage
- Halfbridge rectifier

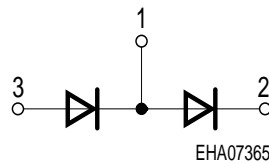
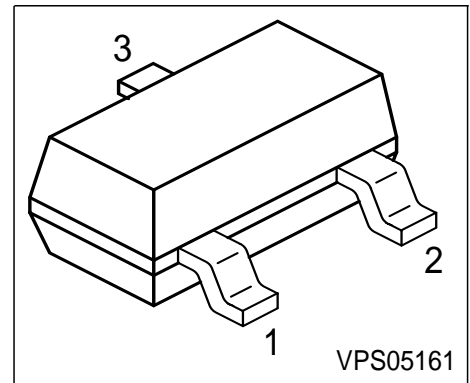

Type	Marking	Pin Configuration			Package
BGX400	GXs	1=C1/A2	2=C2	3=A1	SOT23

Maximum Ratings

Parameter	Symbol	Value	Unit
Diode reverse voltage	V_R	400	V
Peak reverse voltage	V_{RM}	400	
Forward current	I_F	250	mA
Surge forward current, $t = 1 \text{ ms}$	I_{FS}	2	A
Total power dissipation, $T_S = 71 \text{ °C}$	P_{tot}	250	mW
Junction temperature	T_j	150	°C
Storage temperature	T_{stg}	-65 ... 150	

Thermal Resistance

Junction - soldering point ¹⁾	R_{thJS}	≤ 315	K/W
--	------------	------------	-----

¹⁾For calculation of R_{thJA} please refer to Application Note Thermal Resistance

Electrical Characteristics at $T_A = 25^\circ\text{C}$, unless otherwise specified.

Parameter	Symbol	Values			Unit
		min.	typ.	max.	
DC characteristics					
Breakdown voltage $I_{(BR)} = 100 \mu\text{A}$	$V_{(BR)}$	400	-	-	V
Forward voltage $I_F = 1 \text{ A}$ $I_F = 2 \text{ A}$	V_F	- -	- -	1.6 2	
Reverse current $V_R = 400 \text{ V}$	I_R	-	-	1	μA
Reverse current $V_R = 400 \text{ V}, T_A = 150^\circ\text{C}$	I_R	-	-	50	
AC characteristics					
Diode capacitance $V_R = 0 \text{ V}, f = 1 \text{ MHz}$	C_D	-	10	-	pF
Reverse recovery time $I_F = 200 \text{ mA}, I_R = 200 \text{ mA}, R_L = 100 \Omega$, measured at $I_R = 20 \text{ mA}$	t_{rr}	-	1	-	μs

Test circuit for reverse recovery time

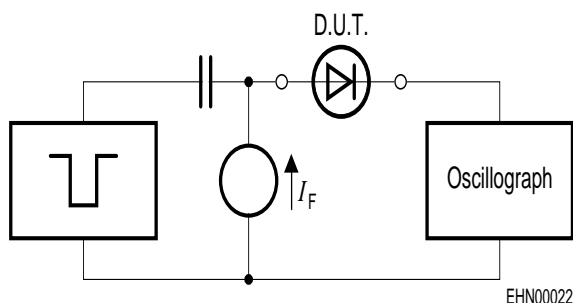

Pulse generator: $t_p = 10 \mu\text{s}$, $D = 0.05$,
 $t_f = 0.6 \text{ ns}$, $R_i = 50 \Omega$

Oscilloscope: $R = 50 \Omega$, $t_r = 0.35 \text{ ns}$,
 $C \leq 1 \text{ pF}$

Forward current $I_F = f(V_F)$

$T_A = 25^\circ\text{C}$

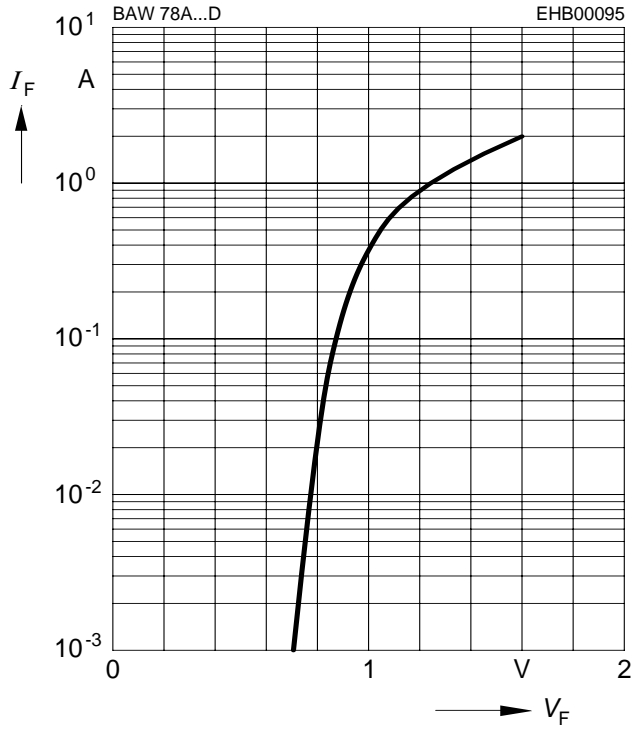

Reverse current $I_R = f(T_A)$

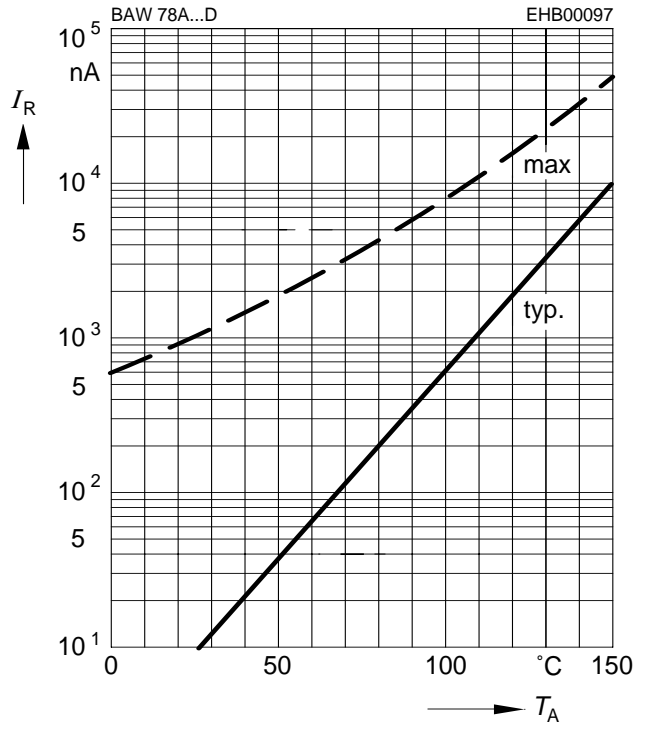

Forward current $I_F = f(T_S)$

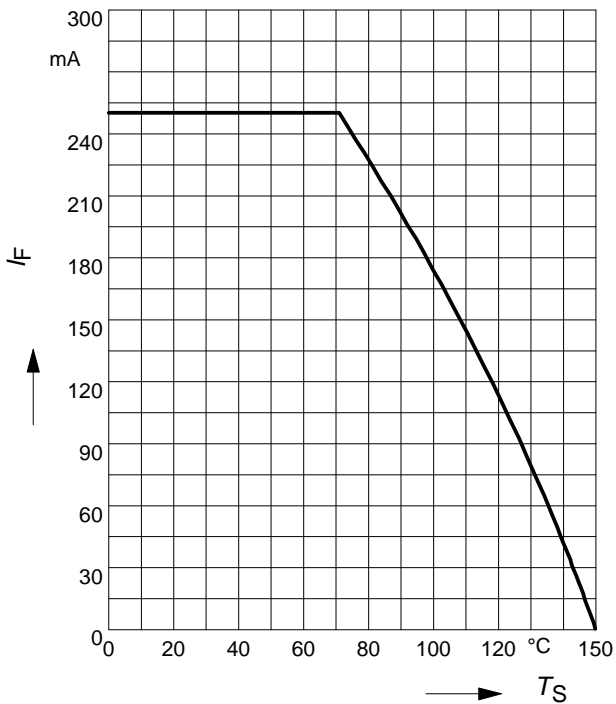

Permissible Pulse Load $R_{thJS} = f(t_p)$

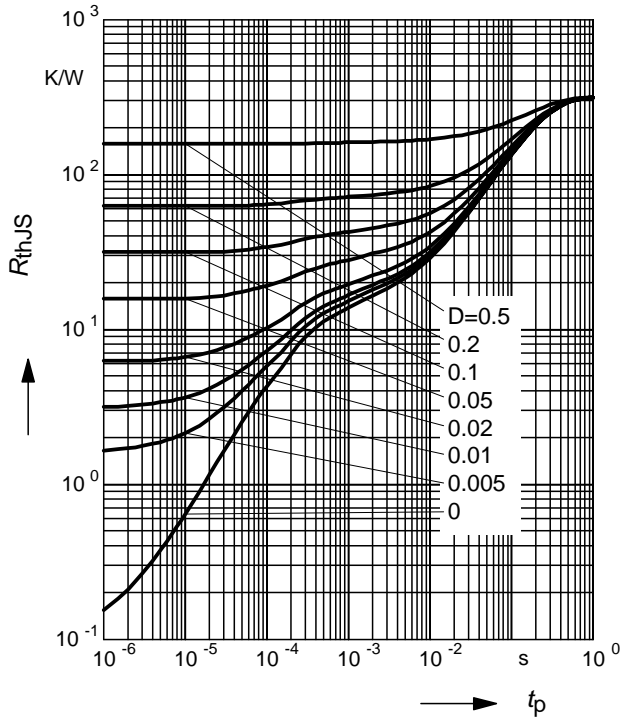

Permissible Pulse Load

$I_{Fmax} / I_{FDC} = f(t_p)$

