

NXP 5 V wideband IQ modulators BGX710x

Strong RF performance with flexible DAC interfacing

Designed for high linearity and low noise floor, these IQ modulators operate between 400 MHz and 4 GHz, while consuming 10% less current than the closest competition competitive solution (<1 W). The power down mode enables even greater levels of power reductions down to more than 6 mA. Strong RF performance is achieved due to the monotonic IP3_o behavior versus frequency, the lowest unadjusted carrier feed through and highest unadjusted sideband suppression in the market. Additionally, flexibility interfacing with any DAC is possible from the RF performance independent of common mode voltage.

Key features

- ▶ IQ modulator performances independent of the IQ common mode voltage ($V_{cm} = 0.25$ to 3.3 V)
- ▶ High linearity (IP3_o = 27 dBm)
- ▶ Flat gain between 400 MHz and 4 GHz (less than 0.5dB variation)
- ▶ High RF output power for 1V_{pp} differential I/Q input (BGX7101: 4 dBm, BGX7100: -0.2 dBm)
- ▶ Very low noise floor (-158 dBm/Hz)
- ▶ Monotonic IP3_o behavior vs frequency
- ▶ Lowest unadjusted Carrier Feedthrough (-50 dBm at -7 dBm output power @ 1960 MHz)
- ▶ Best in class unadjusted sideband suppression (45 dBc at -7 dBm output power @ 1960 MHz)
- ▶ 1dB IQ baseband bandwidth (BGX7101: 650 MHz, BGX7100: 400 MHz)
- ▶ Low power consumption of < 1 W
- ▶ Fast power-down feature (<1μs) via Pon/off pin
- ▶ ESD protection >2 kV HBM, 650 V FCDM on all pins

Applications

- ▶ Macro, micro, and femto base stations
- ▶ Point-to-point backhaul repeaters
- ▶ Software-defined radios
- ▶ Telecom towers, remote radio units
- ▶ Cable modem termination system
- ▶ RF vector signal generators and other measurement instruments

The NXP BGX710x family is a series of 5 V wideband IQ modulators that operate between 400 MHz and 4 GHz while consuming 10% less current than their closest competitors (< 1 W). The power-down mode increases power savings further, lowering consumption to just 6 mA during a receive slot in TDD systems. The power savings are made possible by a fast power-down of less than 1μs.



The devices are designed for high linearity and low noise floor. Their performance on IP3o behavior versus frequency is very strong. Where other devices show chaotic output, these devices are almost flat over the frequency range. Low unadjusted carrier feedthrough, along with the highest unadjusted sideband suppression available on the market, results in very stable operation over the entire temperature range.

Because their RF performance is independent of common mode voltage, these modulators offer flexible interfacing with any DAC. This simplifies design-in, improves performance by

retaining the IQ modulator's output power, and can lower the bill of materials.

Typical applications place the IQ modulator as part of the transmit path of a base station, positioned after the DAC and before the amplifier. After the signals are fed to the I-DAC and Q-DAC, they are converted to the analog domain. Before the I and Q signals enter the IQ modulator, they are first low-pass filtered through a reconstruction filter to remove any aliasing signals. At the IQ modulator, the signals are up-converted to RF using an LO signal coming from the PLL/VCO device, typically referred to as the LO generator.

Key parameters

Type	Package	Frequency range (MHz)	Mode Poif consumption (mA)	V _{cc} (V)	I _{cc} (mA)	Gain (dB)	Noise Floor (dBm/Hz)	PL ⁽¹⁾ (dB)	IP3 _o (dBm)	Po 1V _{pp} differential (dBm)	Sideband suppression (dBc)	Carrier feedthrough (dBm)	S11_LO (dB)
BGX7100	SOT616-3	400 - 4000	6	5	175	1.8	-158	11.5	27	-0.2	55	-48	12
BGX7101	SOT616-3	400 - 4000	6	5	178	6	-158	12	27	4	55	-48	12

Typical BGX710x application in the transmit path of a base station

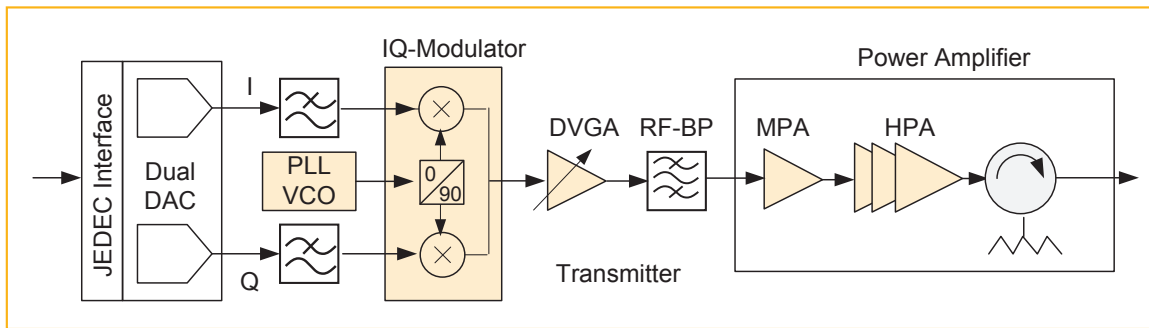

Colored blocks are NXP solutions

UNLEASH^{RF}

Unleash the performance of your RF and microwave designs

www.nxp.com

© 2012 NXP Semiconductors N.V.

All rights reserved. Reproduction in whole or in part is prohibited without the prior written consent of the copyright owner. The information presented in this document does not form part of any quotation or contract, is believed to be accurate and reliable and may be changed without notice. No liability will be accepted by the publisher for any consequence of its use. Publication thereof does not convey nor imply any license under patent- or other industrial or intellectual property rights.

Date of release: October 2012

Document order number: 9397 750 17342

Printed in the Netherlands