

Headphone amplifier for CD-ROMs

BH3541F / BH3544F

The BH3541F and BH3544F are digital-source dual headphone amplifiers. The BH3541F has a fixed gain of 0dB and the BH3544F has a fixed gain of 6dB so that external gain setting is unnecessary. Both the BH3541F and BH3544F have internal mute functions so that prevention of the popping sound when power is turned on and off is greatly simplified. Also, these ICs are equipped with thermal shutdown circuits to prevent damage from short circuits.

| Product name | Fixed gain |
|--------------|------------|
| BH3541F | 0dB |
| BH3544F | 6dB |

●Applications

Devices that use the headphone output from CD-ROMs, CDs, MDs, personal computers, notebook computers, camcorders, etc.

●Features

- 1) Internal mute function to prevent popping sounds when the power is turned on and off.
- 2) Built-in thermal shutdown circuit (150°C) to prevent damage to the IC if a short circuit occurs.
- 3) Compact SOP8 pin package.

●Absolute maximum ratings (Ta = 25°C)

| Parameter | Symbol | Limits | Unit |
|-----------------------|------------------|------------|------|
| Applied voltage | V _{Max} | 7.0 | V |
| Power dissipation | P _d | 450 * | mW |
| Operating temperature | T _{opr} | -25 ~ +75 | °C |
| Storage temperature | T _{stg} | -55 ~ +125 | °C |

*Reduced by 4.5mW for each increase in Ta of 1°C over 25°C.

●Recommended operating conditions (Ta = 25°C)

| Parameter | Symbol | Min. | Typ. | Max. | Unit |
|----------------------|-----------------|------|------|------|------|
| Power supply voltage | V _{cc} | 2.8 | - | 6.5 | V |

Optical disc ICs

●Block diagram

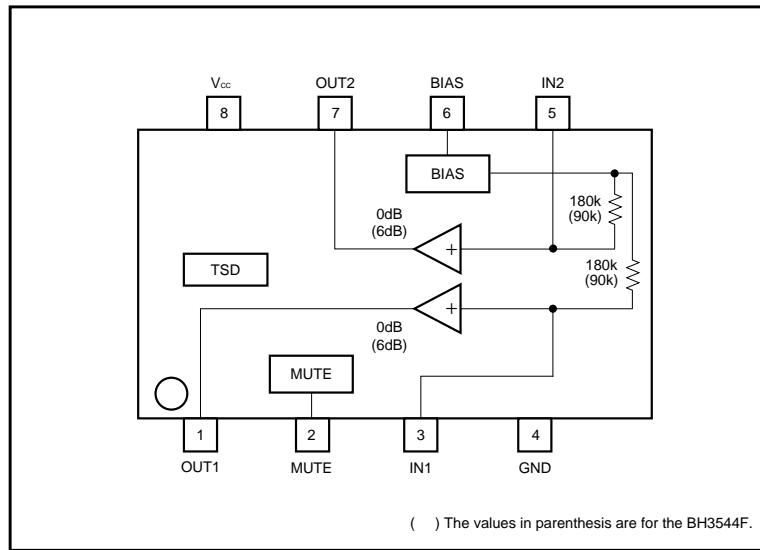

Optical disc ICs

●Pin descriptions

| Pin No. | Pin name | I / O | Pin voltage | Internal equivalent circuit | Function |
|---------|----------|-------|---------------------|-----------------------------|--------------------------------------------------------------------------------------------------------------------------------------------------|
| 1 | OUT1 | O | 2.1V | | Output pin |
| 7 | OUT2 | O | 2.1V (Vcc=5V) | | |
| 2 | MUTE | I | 0.1V (When open) | | Mute control pin (set to low for prevention of popping noise when power is turned on and off). Operating : High Muting : Low (open) |
| 3 | IN1 | I | 2.1V | | Input pin |
| 5 | IN2 | I | 2.1V (Vcc=5V) | | |
| 6 | BIAS | I / O | 2.1V (Vcc=5V) | | Bias pin (the external 47μF capacitor also serves as the anti-pop time constant, therefore make the proper considerations be changing it). |
| 4 | GND | I | - | _____ | _____ |
| 8 | Vcc | I | - | _____ | _____ |

Optical disc ICs

● Measurement conditions

| Signal | SW table | | | | | | Monitor | Conditions |
|------------------|----------|-----|-----|-----|------|------|------------|-----------------------------------------------------------------------------------------------------|
| | SW1 | SW3 | SW5 | SW7 | SW8A | SW8B | | |
| I _Q | 1 | 1 | 1 | 1 | 2 | OFF | IQ | – |
| V _{TM} | – | – | – | – | – | – | – | – |
| G _{Vc} | 1 | 2 | 2 | 1 | 2 | ON | V1AC, V2AC | f _{in} =1kHz, V _{IN1/2} =0dBV (V _{IN1/2} =–6dBV), V _{TM} =1.6V |
| ΔG _{Vc} | – | – | – | – | – | – | – | GVC1–GVC2 |
| THD | 1 | 2 | 2 | 1 | 2 | ON | V1AC, V2AC | f _{in} =1kHz, V _{IN1/2} =0dBV (V _{IN1/2} =–6dBV), V _{TM} =1.6V |
| P _{O1} | 1 | 2 | 2 | 1 | 2 | ON | V1AC, V2AC | f _{in} =1kHz, V _{IN1/2} =0dBV (V _{IN1/2} =–6dBV), V _{TM} =1.6V |
| P _{O2} | 2 | 2 | 2 | 2 | 2 | ON | V1AC, V2AC | f _{in} =1kHz, V _{IN1/2} =0dBV (V _{IN1/2} =–6dBV), V _{TM} =1.6V |
| V _{No} | 1 | 1 | 1 | 1 | 2 | ON | V1AC, V2AC | – |
| CS | 1 | 1 | 2 | 1 | 2 | ON | V1AC, V2AC | f _{in} =1kHz, V _{IN2} =0dBV (V _{IN2} =–6dBV), V _{TM} =1.6V |
| | 1 | 2 | 1 | 1 | 2 | ON | V1AC, V2AC | f _{in} =1kHz, V _{IN1} =0dBV (V _{IN1} =–6dBV), V _{TM} =1.6V |
| ATT | 1 | 2 | 2 | 1 | 2 | ON | V1AC, V2AC | f _{in} =1kHz, V _{IN1/2} =0dBV (V _{IN1/2} =–6dBV), V _{TM} =0.3VB |
| RR | 1 | 1 | 1 | 1 | 1 | ON | V1AC, V2AC | V _{RR} =–20dBV, f _{RR} =100Hz |

*() The values in parenthesis are for the BH3544F.

● Circuit operation

Rising edge timing

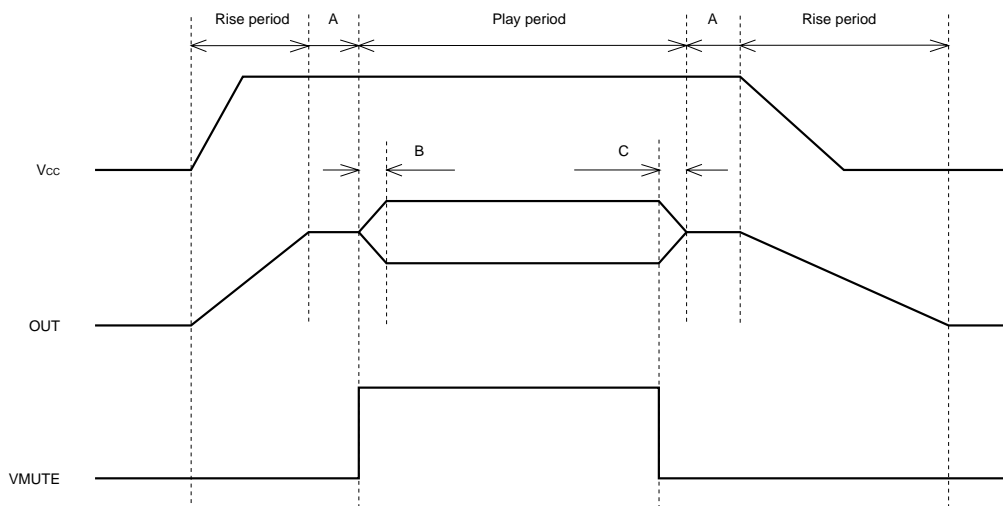

A : MUTE period (use with MUTE = Low to prevent the popping noise when the power is turned on and off).

B : MUTE release time (used to prevent the popping noise at the release of MUTE with the external C2 and R2, and therefore possesses a time constant, so be careful of the timing).

C : MUTE start time (also possesses a time constant like the MUTE release time).

Optical disc ICs

●Application example

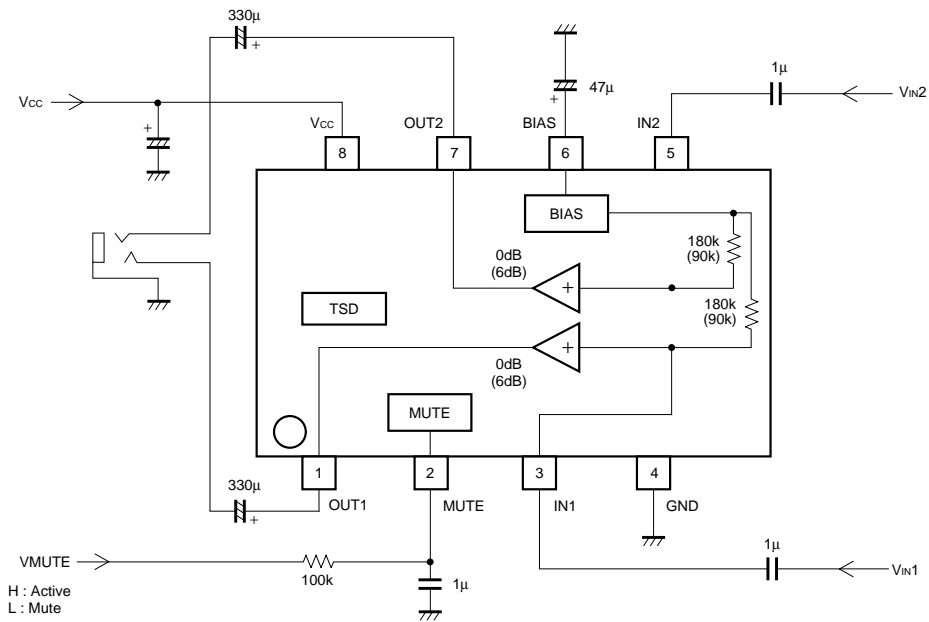

() The values in parenthesis are for the BH3544F.

Fig.2

●Explanation of external components

(1) Input coupling capacitor (C3 and C5)

Determined by the low-band cut-off frequency. Since the input impedance for this IC is 180kΩ, it can be determined by the formula below, but take into consideration the fluctuations, ambient temperature, etc. (a multi-layered ceramic capacitor is recommended).

$$C3 (C5) = 1 / (2\pi \times 180k\Omega \times f)$$

(2) BIAS capacitor (C6)

47µF when V_{CC} = 5V, and 33µF when V_{CC} = 3V. If the capacitance is lowered too much, the electrical characteristics will be adversely affected and popping noise may occur. Therefore, take the sufficient considerations before changing these values.

(3) MUTE pin for anti-pop measures (R2 and C2)

Possesses an impedance of 190kΩ with respect to GND, so if R2 is increased too much, the MUTE mode may become unable to be released.

(4) Output coupling capacitor (C1 and C7)

Determined by the low-band cutoff frequency. As the output load resistance value R_L (assuming that for output protection or current limiting, a resistor R_x will be inserted), it can be determined by the formula below.

$$C1 (C7) = 1 / (2\pi \times (R_L + R_x) \times f)$$

(5) Input gain adjustment resistor (R3 and R4) (for BH3544F only)

Input gain adjustment can be performed by external resistors R3 and R4. The desired gain can be set by the formula given below.

$$G_{vc} = 6 + 20\log (90k\Omega / (90k\Omega + R3)) \quad [dB]$$

Optical disc ICs

●Operation notes

The application example is recommended by ROHM, but before use in your application, be sure to carefully confirm electrical characteristics.

Also, for use with different circuit constants for the external circuits, be sure to leave a sufficient margin for fluctuations in characteristics in the external components and ROHM ICs in not only the static characteristics, but also the transient characteristics as well.

●Electrical characteristic curves

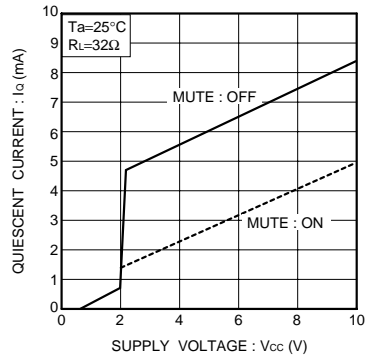

Fig.3 Quiescent current vs. power supply voltage

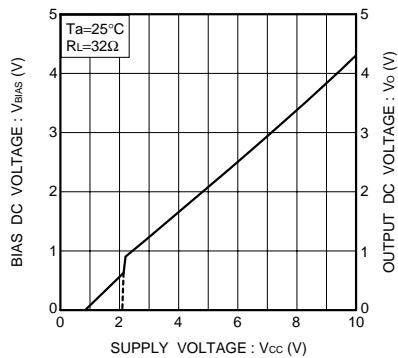

Fig.4 Pin DC current vs. power supply voltage

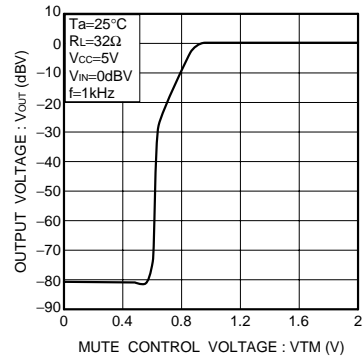

Fig.5 Output voltage vs. MUTE control voltage

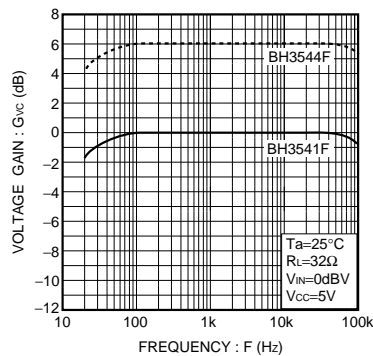

Fig.6 Voltage gain vs. frequency

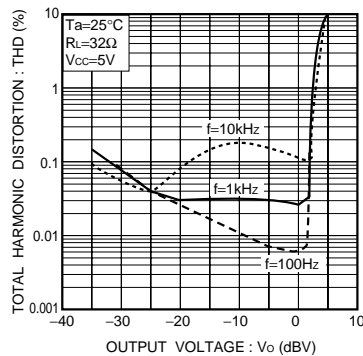

Fig.7 Total harmonic distortion vs. output voltage (I)

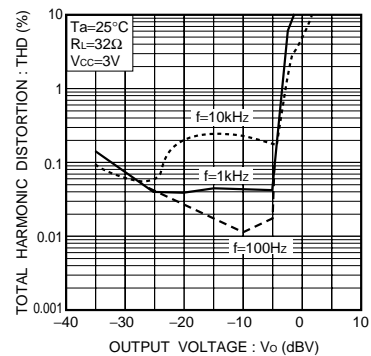

Fig.8 Total harmonic distortion vs. output voltage (II)

Optical disc ICs

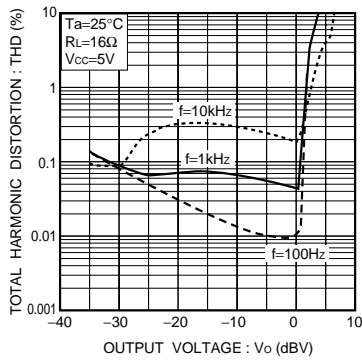

Fig.9 Total harmonic distortion vs. output voltage (III)

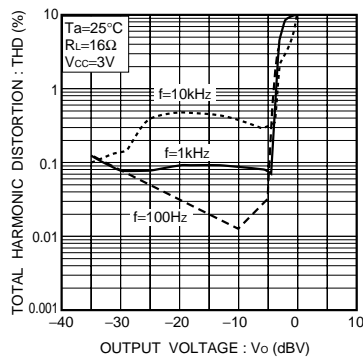

Fig.10 Total harmonic distortion vs. output voltage (IV)

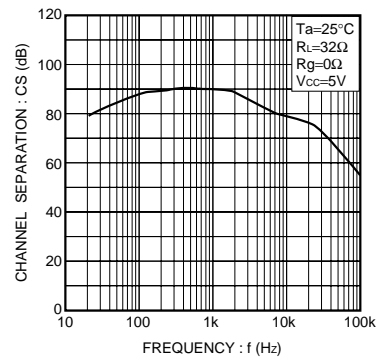

Fig.11 Channel separation vs. frequency

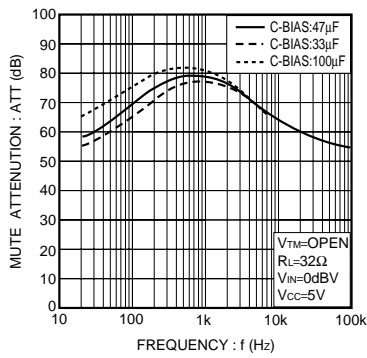

Fig.12 MUTE attenuation vs. frequency

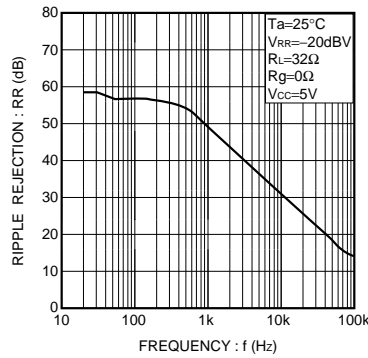

Fig.13 Ripple rejection vs. frequency

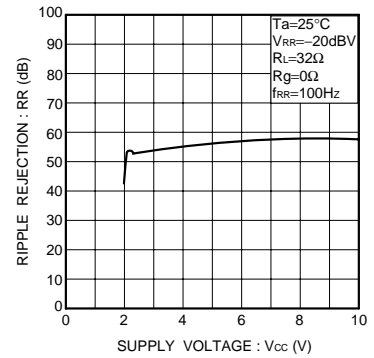

Fig.14 Ripple rejection vs. power supply voltage

●External dimensions (Units : mm)

