

SILICON BRIDGE RECTIFIERS

VOLTAGE RANGE: 50 --- 1000 V
CURRENT: 15.0 A

FEATURES

- ◇ Rating to 1000V PRV
- ◇ Surge overload rating to 300 Amperes peak
- ◇ Ideal for printed circuit board
- ◇ Reliable low cost construction utilizing molded plastic technique results in inexpensive product
- ◇ Lead solderable per MIL-STD-202 method 208
- ◇ Mounting: thru hole for # 8 screw Mounting

BR - W

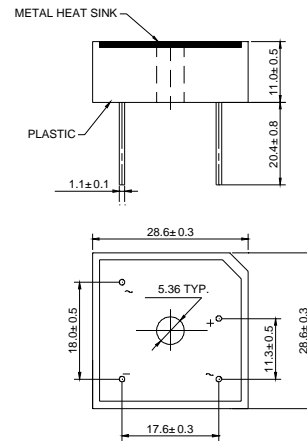

Dimensions in millimeters

MAXIMUM RATINGS AND ELECTRICAL CHARACTERISTICS

Ratings at 25°C ambient temperature unless otherwise specified.

Single phase, half wave, 60 Hz, resistive or inductive load. For capacitive load, derate by 20%.

		BR 15005 (W)	BR 1501 (W)	BR 1502 (W)	BR 1504 (W)	BR 1506 (W)	BR 1508 (W)	BR 1510 (W)	UNITS
Maximum recurrent peak reverse voltage	V_{RRM}	50	100	200	400	600	800	1000	V
Maximum RMS voltage	V_{RMS}	35	70	140	280	420	560	700	V
Maximum DC blocking voltage	V_{DC}	50	100	200	400	600	800	1000	V
Maximum average forward output current @ $T_A=50^\circ C$	$I_{F(AV)}$	15.0							A
Peak forward surge current 8.3ms single half-sine-wave superimposed on rated load	I_{FSM}	300.0							A
Maximum instantaneous forward voltage at 7.5 A	V_F	1.1							V
Maximum reverse current @ $T_A=25^\circ C$ at rated DC blocking voltage @ $T_A=100^\circ C$	I_R	5.0 0.5							μA mA
Operating junction temperature range	T_J	- 55 ---- + 150							$^\circ C$
Storage temperature range	T_{STG}	- 55 ---- + 150							$^\circ C$

FIG.1 – PEAK FORWARD SURGE CURRENT

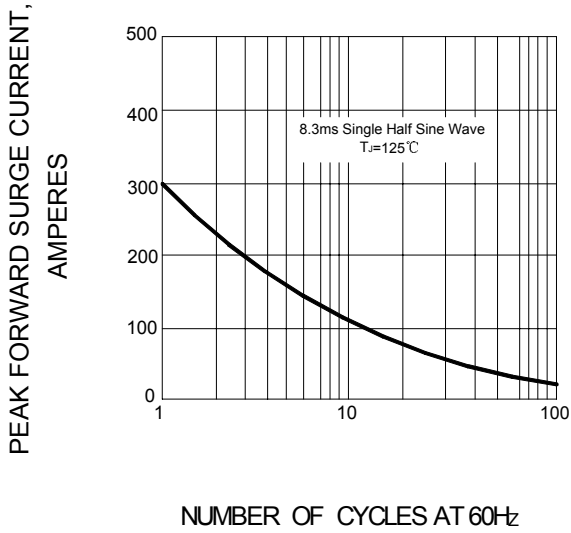

FIG.2 – FORWARD DERATING CURVE

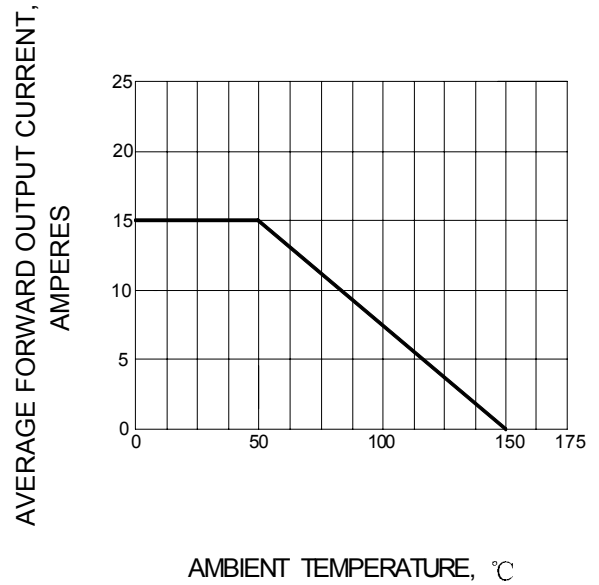

FIG.3 – TYPICAL FORWARD CHARACTERISTIC

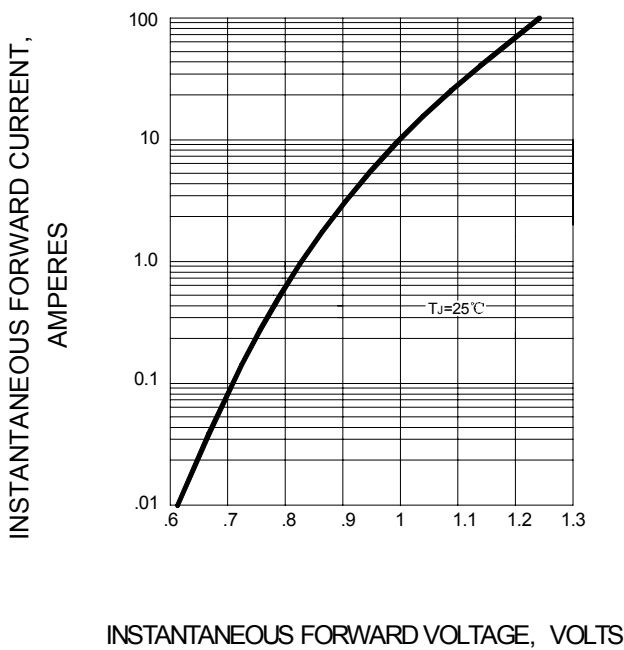

FIG.4 – TYPICAL REVERSE CHARACTERISTIC

