

PNP Epitaxial Planar Transistor

BTB1580SM3

Description

The BTB1580SM3 is a PNP Darlington transistor, designed for use in general purpose amplifier and low speed switching application. Pb-free package process is adopted.

Equivalent Circuit

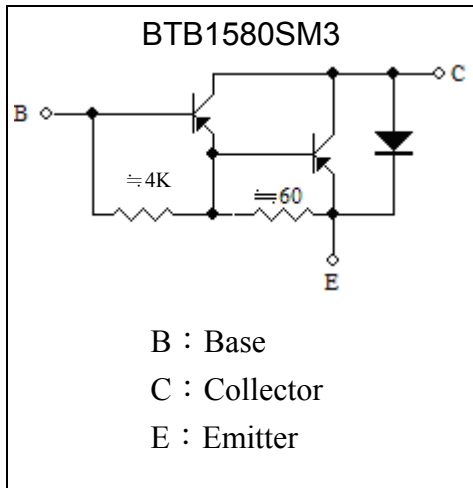

Outline

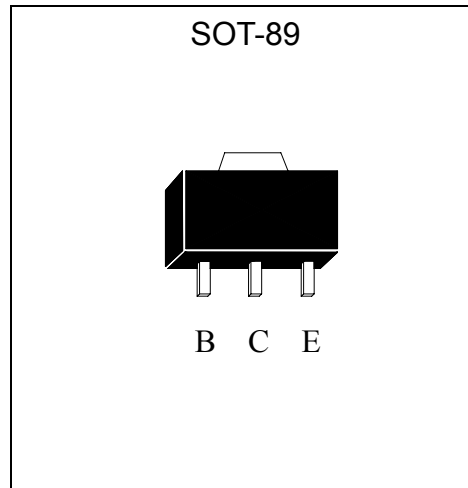

Ordering Information

Device	Package	Shipping
BTB1580SM3-0-T2-G	SOT-89 (Pb-free lead plating and halogen-free package)	1000 pcs / Tape & Reel

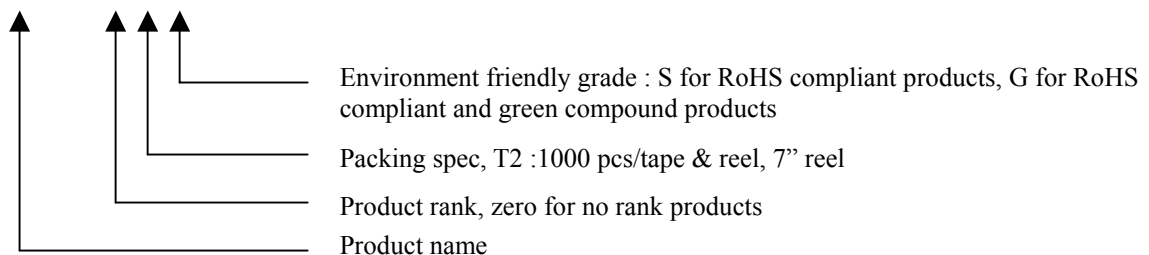



Absolute Maximum Ratings (Ta=25°C)

Parameter	Symbol	Limits	Unit
Collector-Base Voltage	V _{CB0}	-120	V
Collector-Emitter Voltage	V _{CEO}	-120	
Emitter-Base Voltage	V _{EBO}	-5	
Collector Current (DC)	I _C	-4	A
Collector Current (Pulse)	I _{CP}	-6 (Note 1)	
Thermal Resistance, Junction to Ambient	R _{θJA}	208	°C/W
		125 (Note 2)	
		62.5 (Note 3)	
		85 (Note 4)	
Thermal Resistance, Junction to Case	R _{θJC}	43	
Power Dissipation	P _D	0.7	W
		1.2 (Note 2)	
		2.4 (Note 3)	
		1.8 (Note 4)	
Power Dissipation @ T _C =25°C		3.5	
Operating Junction Temperature Range	T _J	-55~+175	°C
Storage Temperature Range	T _{stg}	-55~+175	

- Note : 1. Single Pulse P_w ≤ 350μs, Duty ≤ 2%.
 2. When mounted on a FR-4 PCB with area measuring 10×10×1 mm.
 3. When mounted on a ceramic board with area measuring 40×40×1mm.
 4. When mounted on a FR-4 PCB with area measuring 30×30×1 mm.

Characteristics (Ta=25°C)

Symbol	Min.	Typ.	Max.	Unit	Test Conditions
BV _{CEO}	-120	-	-	V	I _C =-1mA, I _B =0
BV _{CB0}	-120	-	-	V	I _C =-100μA, I _E =0
I _{CB0}	-	-	-100	nA	V _{CB} =-120V, I _E =0
I _{CEO}	-	-	-1	μA	V _{CE} =-120V, I _B =0
I _{EBO}	-	-	-2	mA	V _{EB} =-5V, I _C =0
*V _{CE(sat)}	-	-	-1.8	V	I _C =-2A, I _B =-2mA
*V _{BE(on)}			-2.2	V	V _{CE} =-4V, I _C =-2A
*h _{FE1}	1000	-	-	-	V _{CE} =-4V, I _C =-1A
*h _{FE2}	1000	-	-	-	V _{CE} =-4V, I _C =-2A
C _{ob}	-		200	pF	V _{CB} =-10V, I _E =0A, f=1MHz

*Pulse Test : Pulse Width ≤ 380μs, Duty Cycle ≤ 2%

Recommended soldering footprint

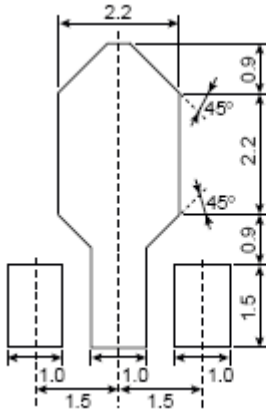

unit : mm

Typical Characteristics

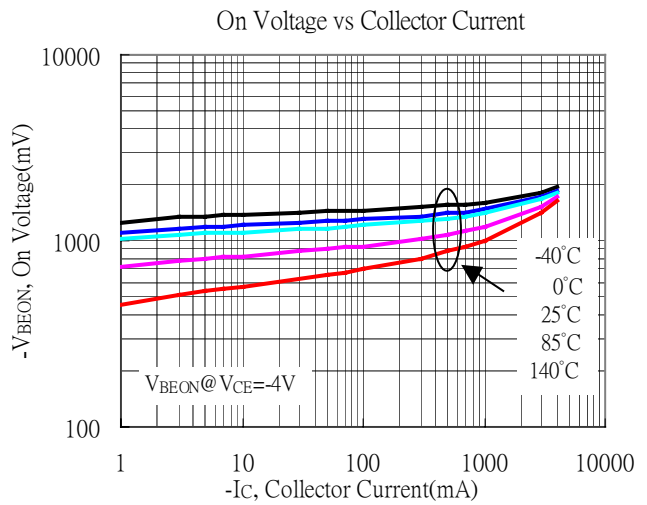
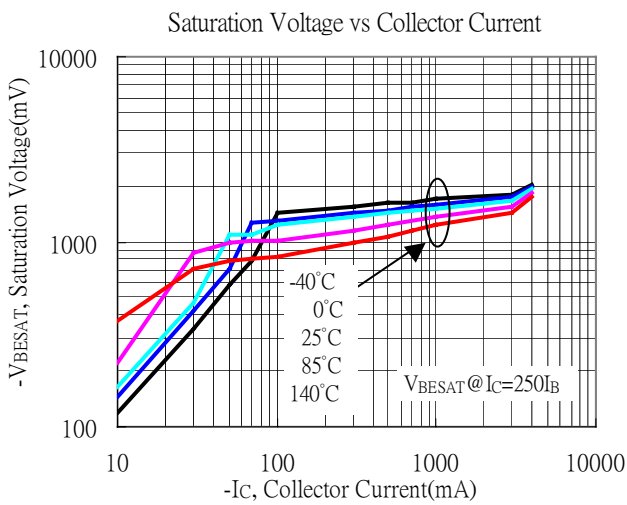
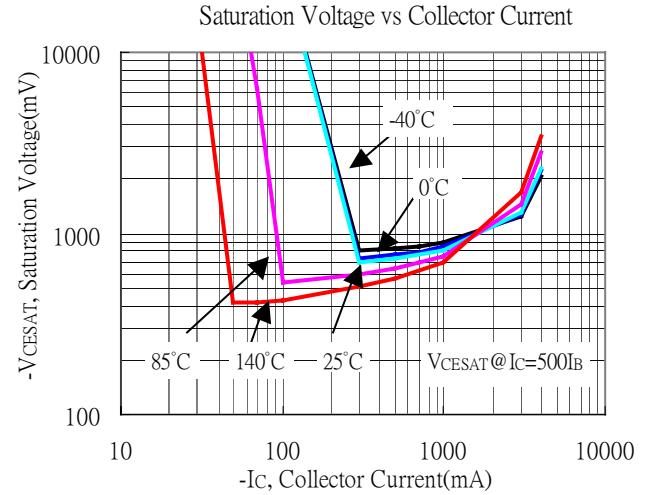
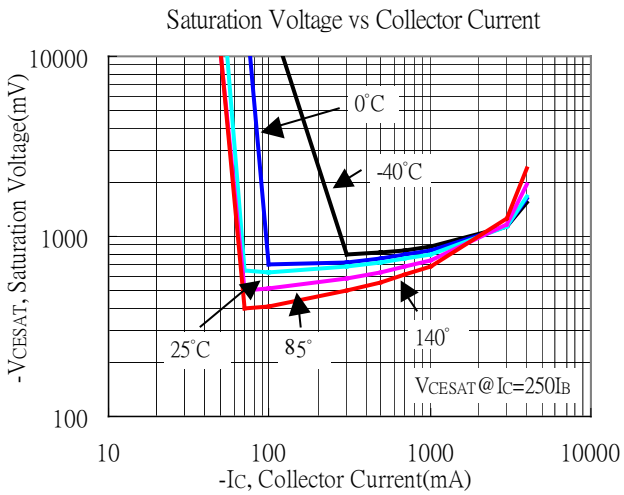
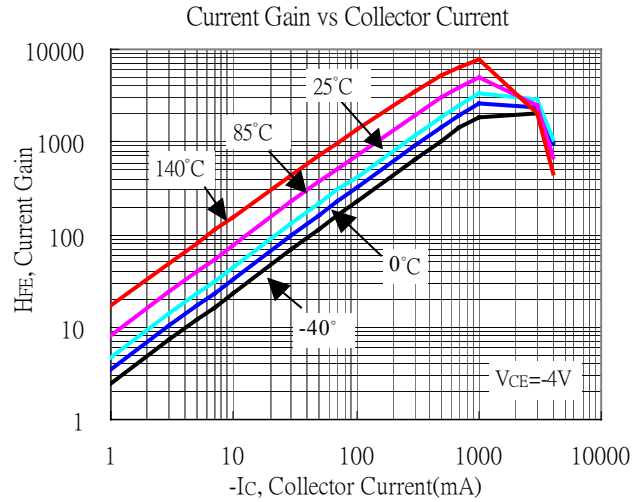
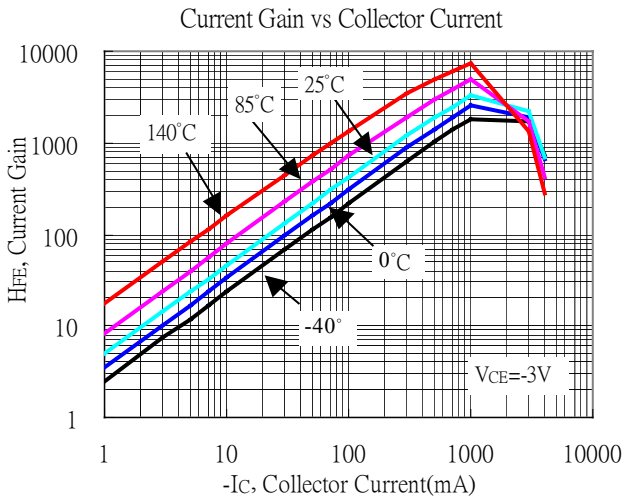

Typical Characteristics(Cont.)

Built-in Diode Characteristics

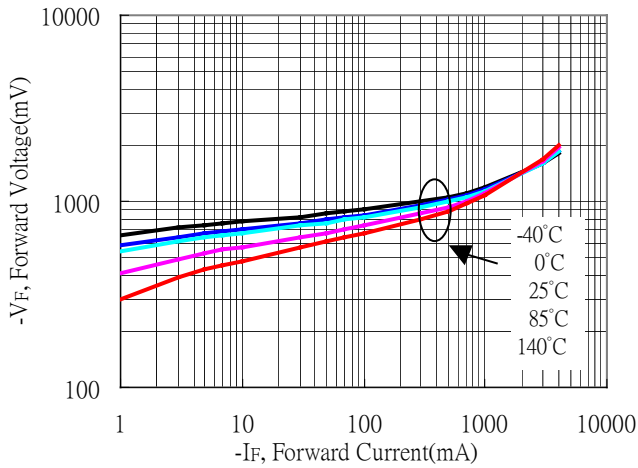

Capacitance vs Reverse-Biased Voltage

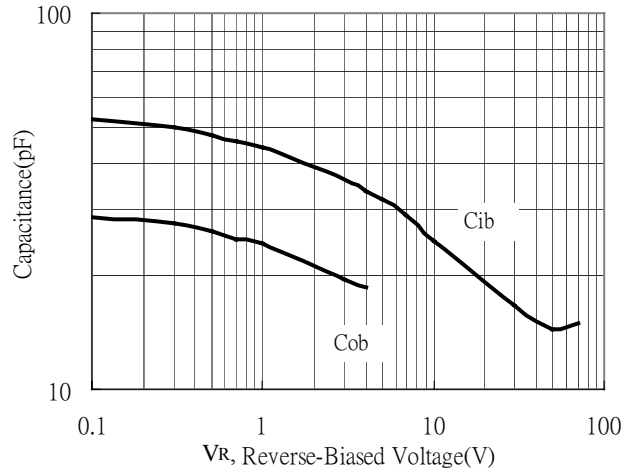

Power Derating Curves

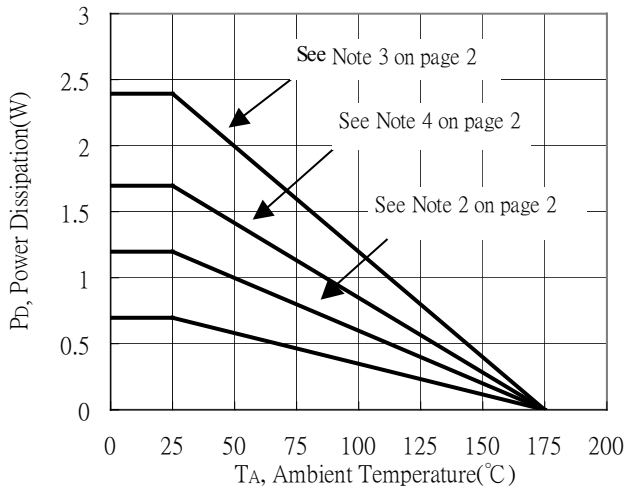

Power Derating Curve

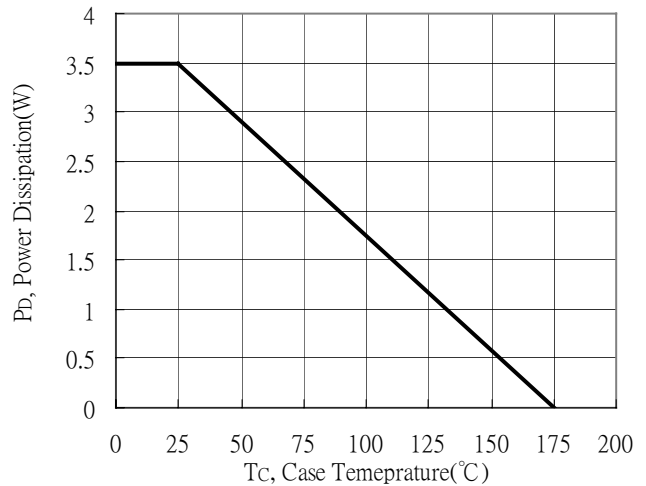

Emitter Grounded Output Characteristics

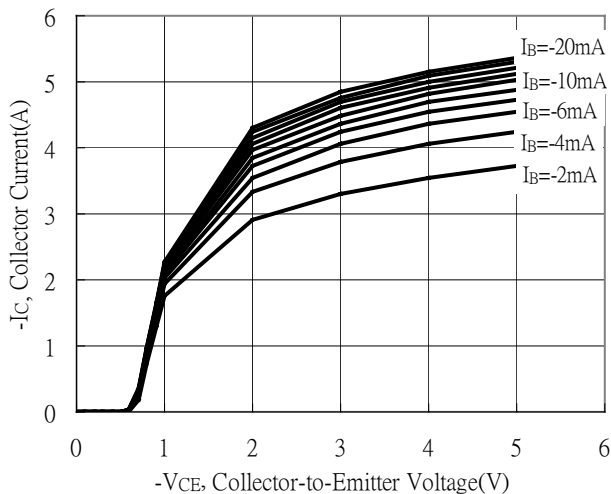

Emitter Grounded Output Characteristics

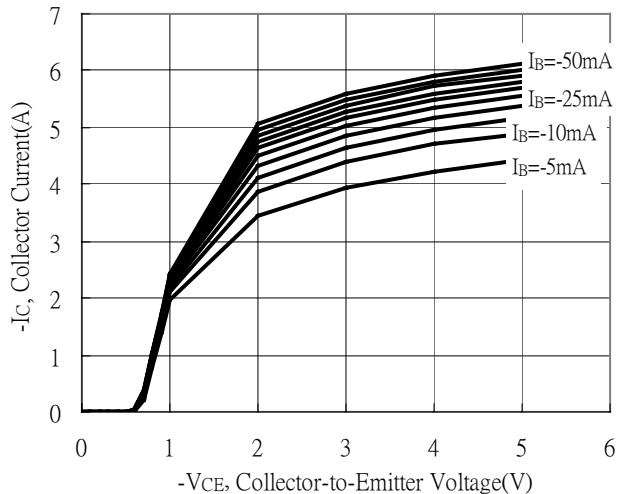

Reel Dimension

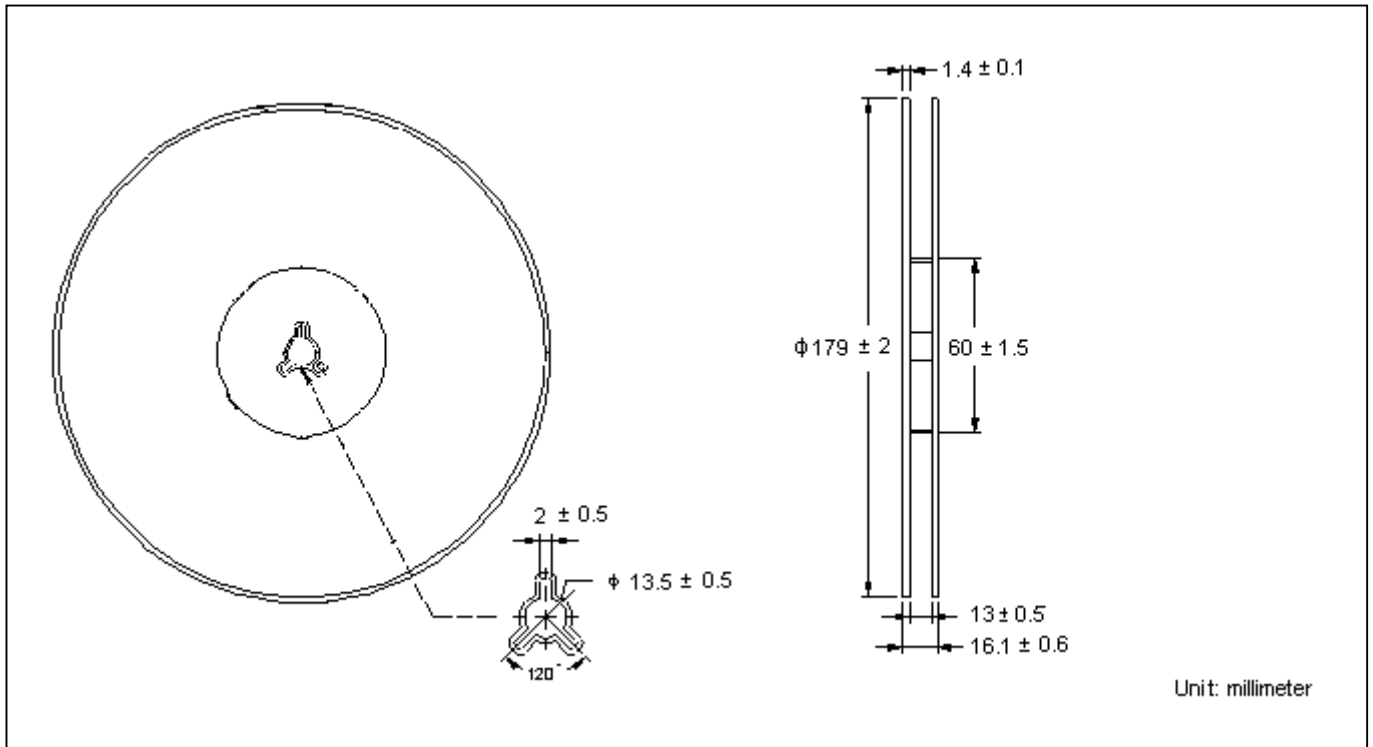

Carrier Tape Dimension

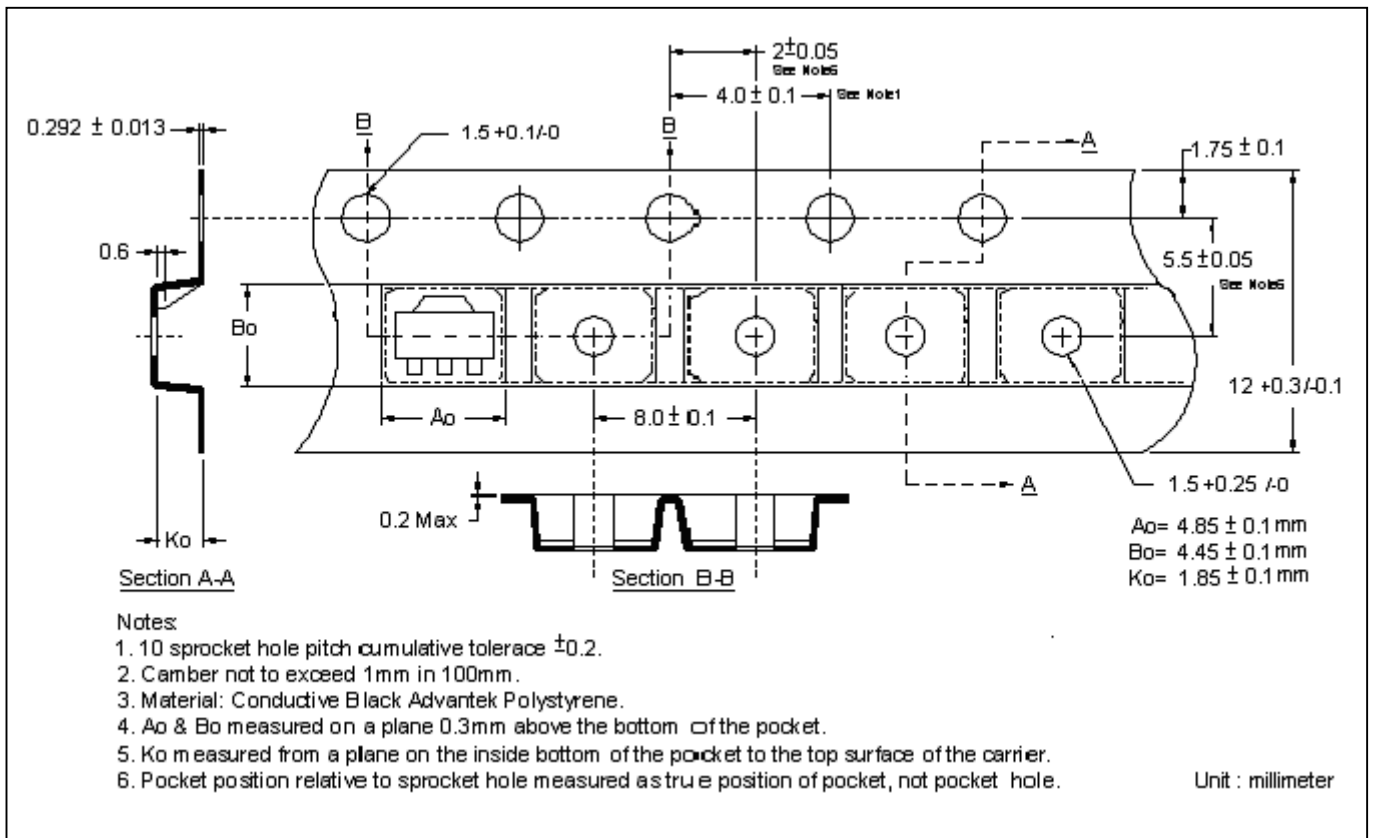

Recommended wave soldering condition

Product	Peak Temperature	Soldering Time
Pb-free devices	260 +0/-5 °C	5 +1/-1 seconds

Recommended temperature profile for IR reflow

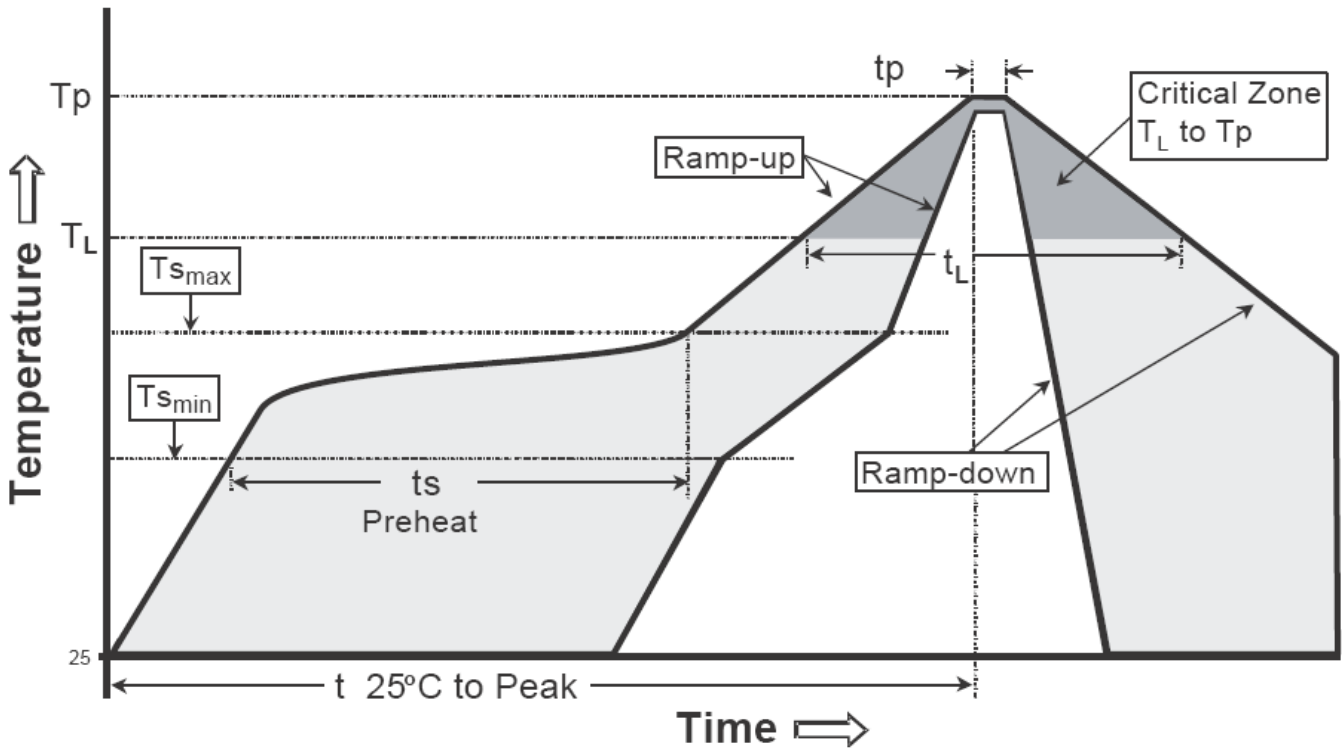

Profile feature	Sn-Pb eutectic Assembly	Pb-free Assembly
Average ramp-up rate (T _{smax} to T _p)	3°C/second max.	3°C/second max.
Preheat		
-Temperature Min(T _{s min})	100°C	150°C
-Temperature Max(T _{s max})	150°C	200°C
-Time(t _{s min} to t _{s max})	60-120 seconds	60-180 seconds
Time maintained above:		
-Temperature (T _L)	183°C	217°C
- Time (t _L)	60-150 seconds	60-150 seconds
Peak Temperature(T _P)	240 +0/-5 °C	260 +0/-5 °C
Time within 5°C of actual peak temperature(tp)	10-30 seconds	20-40 seconds
Ramp down rate	6°C/second max.	6°C/second max.
Time 25 °C to peak temperature	6 minutes max.	8 minutes max.

Note :1. All temperatures refer to topside of the package, measured on the package body surface.
 2. For devices mounted on FR-4 PCB of 1.6mm or equivalent grade PCB. If other grade PCB is used, care should be taken to match the coefficients of thermal expansion between components and PCB. If they are not matched well, the solder joints may crack or the bodies of the parts may crack or shatter as the assembly cools.

SOT-89 Dimension

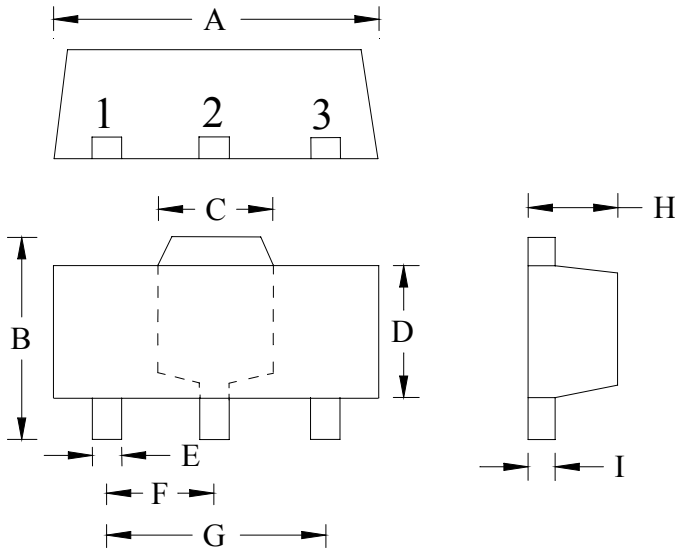

The diagram shows three views of the SOT-89 package: a top view with dimensions A, C, and lead positions 1, 2, 3; a front view with dimensions B, D, E, F, G; and a side view with dimensions H and I.

Marking:

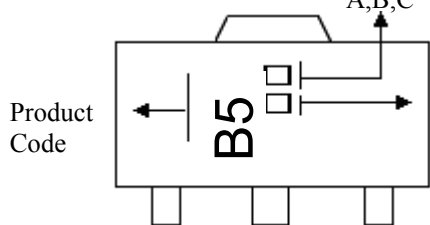

month code: 1~9, A,B,C
 Year code : 6→2006, 7→2007,...

Product Code ← B5 →

Style: Pin 1. Base 2. Collector 3. Emitter

3-Lead SOT-89 Plastic
 Surface Mounted Package
 CYStek Package Code: M3

DIM	Inches		Millimeters		DIM	Inches		Millimeters	
	Min.	Max.	Min.	Max.		Min.	Max.	Min.	Max.
A	0.1732	0.1811	4.40	4.60	F	0.0591	TYP	1.50	TYP
B	0.1551	0.1673	3.94	4.25	G	0.1181	TYP	3.00	TYP
C	0.0610	REF	1.55	REF	H	0.0551	0.0630	1.40	1.60
D	0.0906	0.1024	2.30	2.60	I	0.0138	0.0173	0.35	0.44
E	0.0126	0.0205	0.32	0.52					

- Notes:**
- Controlling dimension: millimeters.
 - Maximum lead thickness includes lead finish thickness, and minimum lead thickness is the minimum thickness of base material.
 - If there is any question with packing specification or packing method, please contact your local CYStek sales office.

Material:

- Lead: Pure tin plated.
- Mold Compound: Epoxy resin family, flammability solid burning class: UL94V-0

Important Notice:

- All rights are reserved. Reproduction in whole or in part is prohibited without the prior written approval of CYStek.
- CYStek reserves the right to make changes to its products without notice.
- CYStek **semiconductor products are not warranted to be suitable for use in Life-Support Applications, or systems.**
- CYStek assumes no liability for any consequence of customer product design, infringement of patents, or application assistance.