

## BUX10

### HIGH POWER NPN SILICON TRANSISTOR

- SGS-THOMSON PREFERRED SALESTYPE
- NPN TRANSISTOR
- HIGH CURRENT CAPABILITY
- FAST SWITCHING SPEED

#### APPLICATIONS

- MOTOR CONTROL
- LINEAR AND SWITCHING INDUSTRIAL EQUIPMENT

#### DESCRIPTION

The BUX10 is a silicon multiepitaxial planar NPN transistor in Jedec TO-3 metal case, intended for use in switching and linear applications in military and industrial equipment.

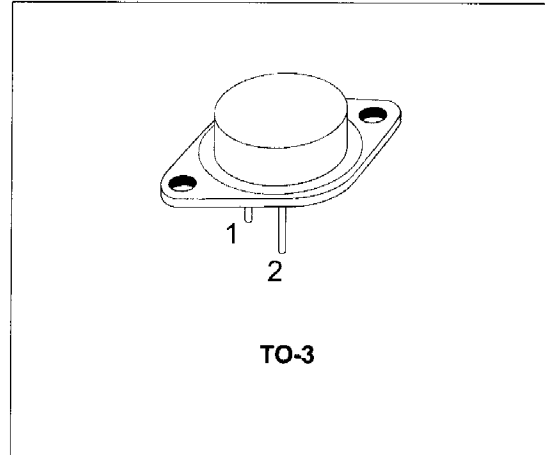

#### INTERNAL SCHEMATIC DIAGRAM

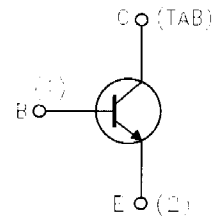

#### ABSOLUTE MAXIMUM RATINGS

Symbol	Parameter	Value	Unit
$V_{CBO}$	Collector-base Voltage ( $I_E = 0$ )	160	V
$V_{CEX}$	Collector-emitter Voltage ( $V_{BE} = -1.5V$ )	160	V
$V_{CEO}$	Collector-emitter Voltage ( $I_B = 0$ )	125	V
$V_{EBO}$	Emitter-base Voltage ( $I_C = 0$ )	7	V
$I_C$	Collector Current	25	A
$I_{CM}$	Collector Peak Current ( $t_P = 10$ ms)	30	A
$I_B$	Base Current	5	A
$P_{tot}$	Total Power Dissipation at $T_{case} \leq 25^\circ C$	150	W
$T_{stg}$	Storage Temperature	-65 to 200	$^\circ C$
$T_j$	Max Operating Junction Temperature	200	$^\circ C$

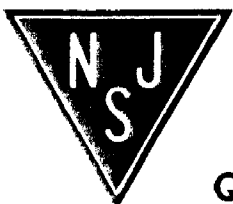

NJ Semi-Conductors reserves the right to change test conditions, parameter limits and package dimensions without notice. Information furnished by NJ Semi-Conductors is believed to be both accurate and reliable at the time of going to press. However, NJ Semi-Conductors assumes no responsibility for any errors or omissions discovered in its use. NJ Semi-Conductors encourages customers to verify that datasheets are current before placing orders.

## BUX10

### THERMAL DATA

$R_{thj-case}$	Thermal Resistance Junction-case	Max	1.17	$^{\circ}C/W$
----------------	----------------------------------	-----	------	---------------

### ELECTRICAL CHARACTERISTICS ( $T_{case} = 25^{\circ}C$ unless otherwise specified)

Symbol	Parameter	Test Conditions	Min.	Typ.	Max.	Unit	
$I_{CEO}$	Collector Cut-off Current ( $I_B = 0$ )	$V_{CE} = 100 V$			1.5	mA	
$I_{CEX}$	Collector Cut-off Current	$V_{CE} = 160 V$ $T_{case} = 125^{\circ}C$ $V_{CE} = 160 V$			1.5	mA	
		$V_{BE} = -1.5V$ $V_{BE} = -1.5V$			6	mA	
$I_{EBO}$	Emitter Cut-off Current ( $I_C = 0$ )	$V_{EB} = 5 V$			1	mA	
$V_{CEO(sus)*}$	Collector-Emitter Sustaining Voltage	$I_C = 200 mA$	125			V	
$V_{EBO}$	Emitter-Base Voltage ( $I_C = 0$ )	$I_E = 50 mA$	7			V	
$V_{CE(sat)*}$	Collector-Emitter Saturation Voltage	$I_C = 10 A$ $I_C = 20 A$			0.3 0.7	V V	
		$I_B = 1 A$ $I_B = 2 A$			0.6 1.2	V V	
$V_{BE(sat)*}$	Base-Emitter Saturation Voltage	$I_C = 20 A$			1.6	2	V
$h_{FE}$	DC Current Gain	$I_C = 10 A$ $I_C = 20 A$			20 10	60	
		$V_{CE} = 2 V$ $V_{CE} = 4 V$					
$I_{S/b}$	Second Breakdown Collector Current	$V_{CE} = 30 V$ $V_{CE} = 48 V$			5 1	A A	
		$t = 1 s$ $t = 1 s$					
$f_T$	Transistor Frequency	$I_C = 1 A$ $f = 10MHz$			8		MHz
$t_{on}$	Turn-on Time	$I_C = 20 A$ $V_{CC} = 30V$			0.5	1.5	$\mu s$
		$I_{B1} = 2 A$					
$t_s$	Storage Time	$I_C = 20 A$			0.6	1.2	$\mu s$
$t_f$	Fall Time	$V_{CC} = 30V$			0.15	0.3	$\mu s$
		$I_{B1} = - I_{B2} = 2A$					
	Clamped $E_{S/b}$ Collector Current	$V_{clamp} = 125 V$ $L = 500 \mu H$	20				A

\* Pulsed: Pulse duration = 300 $\mu s$ , duty cycle  $\leq 2\%$

## TO-3 MECHANICAL DATA

DIM.	mm			inch		
	MIN.	TYP.	MAX.	MIN.	TYP.	MAX.
A	11.00		13.10	0.433		0.516
B	0.97		1.15	0.038		0.045
C	1.50		1.65	0.059		0.065
D	8.32		8.92	0.327		0.351
E	19.00		20.00	0.748		0.787
G	10.70		11.10	0.421		0.437
N	16.50		17.20	0.649		0.677
P	25.00		26.00	0.984		1.023
R	4.00		4.09	0.157		0.161
U	38.50		39.30	1.515		1.547
V	30.00		30.30	1.187		1.193

