

DO-35 Glass-Encapsulate Diodes

Zener Diodes

Features

- P_d 0.5W
- V_z 2.4V-75V

Applications

- Stabilizing Voltage

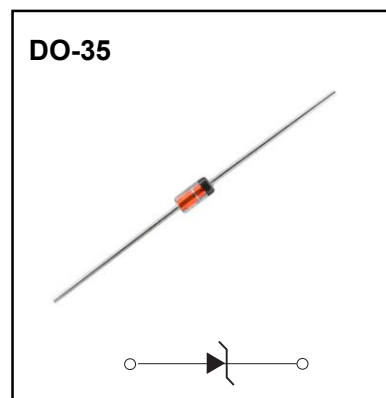

Limiting Values (Absolute Maximum Rating)

Item	Symbol	Unit	Conditions	Max
Power dissipation	P_d	mW	$L=4\text{mm}, T_L=25^\circ\text{C}$	500
Zener current	I_z	mA	P_{tot} / V_z	See Table
Maximum junction temperature	T_j	$^\circ\text{C}$		175
Storage temperature range	T_{stg}	$^\circ\text{C}$		-65 to +175

Electrical Characteristics ($T_a=25^\circ\text{C}$ Unless otherwise specified)

Item	Symbol	Unit	Conditions	Max
Thermal resistance	$R_{\theta JA}$	$^\circ\text{C}/\text{W}$	junction to ambient air, $L=4\text{mm}, T_L=\text{constant}$	300
Forward voltage	V_F	V	$I_F=200\text{mA}$	1.5

Electrical Characteristics (T_A=25°C unless otherwise noted)

BZX55C..

Part Number	Zener voltage range		Dynamic resistance		Test current	Temperature Coefficient		Test current	Reverse leakage current		
	V _Z at I _{ZT}		R _{ZJT} at I _{ZT} f = 1 KHz	R _{ZJK} at I _{ZK} f = 1 KHz	I _{ZT}	TK _{VZ}		I _{ZK}	I _R at T _{amb} =25°C	I _R at T _{amb} =150°C	at V _R
	V		Ω		mA	%K		mA	μA		V
	Min.	Max.				Min.	Max.				
BZX55C2V4	2.28	2.56	< 85	< 600	5	- 0.09	- 0.06	1	< 50	< 100	1
BZX55C2V7	2.5	2.9	< 85	< 600	5	- 0.09	- 0.06	1	< 10	< 50	1
BZX55C3V0	2.8	3.2	< 85	< 600	5	- 0.08	- 0.05	1	< 4	< 40	1
BZX55C3V3	3.1	3.5	< 85	< 600	5	- 0.08	- 0.05	1	< 2	< 40	1
BZX55C3V6	3.4	3.8	< 85	< 600	5	- 0.08	- 0.05	1	< 2	< 40	1
BZX55C3V9	3.7	4.1	< 85	< 600	5	- 0.08	- 0.05	1	< 2	< 40	1
BZX55C4V3	4	4.6	< 75	< 600	5	- 0.06	- 0.03	1	< 1	< 20	1
BZX55C4V7	4.4	5	< 60	< 600	5	- 0.05	0.02	1	< 0.5	< 10	1
BZX55C5V1	4.8	5.4	< 35	< 550	5	- 0.02	0.02	1	< 0.1	< 2	1
BZX55C5V6	5.2	6	< 25	< 450	5	- 0.05	0.05	1	< 0.1	< 2	1
BZX55C6V2	5.8	6.6	< 10	< 200	5	0.03	0.06	1	< 0.1	< 2	2
BZX55C6V8	6.4	7.2	< 8	< 150	5	0.03	0.07	1	< 0.1	< 2	3
BZX55C7V5	7	7.9	< 7	< 50	5	0.03	0.07	1	< 0.1	< 2	5
BZX55C8V2	7.7	8.7	< 7	< 50	5	0.03	0.08	1	< 0.1	< 2	6.2
BZX55C9V1	8.5	9.6	< 10	< 50	5	0.03	0.09	1	< 0.1	< 2	6.8
BZX55C10	9.4	10.6	< 15	< 70	5	0.03	0.1	1	< 0.1	< 2	7.5
BZX55C11	10.4	11.6	< 20	< 70	5	0.03	0.11	1	< 0.1	< 2	8.2
BZX55C12	11.4	12.7	< 20	< 90	5	0.03	0.11	1	< 0.1	< 2	9.1
BZX55C13	12.4	14.1	< 26	< 110	5	0.03	0.11	1	< 0.1	< 2	10
BZX55C15	13.8	15.6	< 30	< 110	5	0.03	0.11	1	< 0.1	< 2	11
BZX55C16	15.3	17.1	< 40	< 170	5	0.03	0.11	1	< 0.1	< 2	12
BZX55C18	16.8	19.1	< 50	< 170	5	0.03	0.11	1	< 0.1	< 2	13
BZX55C20	18.8	21.2	< 55	< 220	5	0.03	0.11	1	< 0.1	< 2	15
BZX55C22	20.8	23.3	< 55	< 220	5	0.04	0.12	1	< 0.1	< 2	16
BZX55C24	22.8	25.6	< 80	< 220	5	0.04	0.12	1	< 0.1	< 2	18
BZX55C27	25.1	28.9	< 80	< 220	5	0.04	0.12	1	< 0.1	< 2	20
BZX55C30	28	32	< 80	< 220	5	0.04	0.12	1	< 0.1	< 2	22
BZX55C33	31	35	< 80	< 220	5	0.04	0.12	1	< 0.1	< 2	24
BZX55C36	34	38	< 80	< 220	5	0.04	0.12	1	< 0.1	< 2	27
BZX55C39	37	41	< 90	< 500	2.5	0.04	0.12	0.5	< 0.1	< 5	30
BZX55C43	40	46	< 90	< 600	2.5	0.04	0.12	0.5	< 0.1	< 5	33
BZX55C47	44	50	< 110	< 700	2.5	0.04	0.12	0.5	< 0.1	< 5	36
BZX55C51	48	54	< 125	< 700	2.5	0.04	0.12	0.5	< 0.1	< 10	39
BZX55C56	52	60	< 135	< 1000	2.5	0.04	0.12	0.5	< 0.1	< 10	43
BZX55C62	58	66	< 150	< 1000	2.5	0.04	0.12	0.5	< 0.1	< 10	47
BZX55C68	64	72	< 200	< 1000	2.5	0.04	0.12	0.5	< 0.1	< 10	51
BZX55C75	70	79	< 250	< 1500	2.5	0.04	0.12	0.5	< 0.1	< 10	56

Electrical Characteristics (T_A=25°C unless otherwise noted)

BZX55B..

Part Number	Zener voltage range		Dynamic resistance		Test current	Temperature Coefficient		Test current	Reverse leakage current		
	V _Z at I _{ZT}		R _{ZJT} at I _{ZT} f = 1 KHz	R _{ZJK} at I _{ZK} f = 1 KHz	I _{ZT}	TK _{VZ}		I _{ZK}	I _R at T _{amb} =25°C	I _R at T _{amb} =150°C	at V _R
	V		Ω		mA	%K		mA	μA		V
	Min.	Max.				Min.	Max.				
BZX55B2V7	2.64	2.76	< 85	< 600	5	- 0.09	- 0.06	1	< 10	< 50	1
BZX55B3V0	2.94	3.06	< 90	< 600	5	- 0.08	- 0.05	1	< 4	< 40	1
BZX55B3V3	3.24	3.36	< 90	< 600	5	- 0.08	- 0.05	1	< 2	< 40	1
BZX55B3V6	3.52	3.68	< 90	< 600	5	- 0.08	- 0.05	1	< 2	< 40	1
BZX55B3V9	3.82	3.98	< 90	< 600	5	- 0.08	- 0.05	1	< 2	< 40	1
BZX55B4V3	4.22	4.38	< 90	< 600	5	- 0.06	- 0.03	1	< 1	< 20	1
BZX55B4V7	4.6	4.8	< 80	< 600	5	- 0.05	0.02	1	< 0.5	< 10	1
BZX55B5V1	5	5.2	< 60	< 550	5	- 0.02	0.02	1	< 0.1	< 2	1
BZX55B5V6	5.48	5.72	< 40	< 450	5	- 0.05	0.05	1	< 0.1	< 2	1
BZX55B6V2	6.08	6.32	< 10	< 200	5	0.03	0.06	1	< 0.1	< 2	2
BZX55B6V8	6.66	6.94	< 8	< 150	5	0.03	0.07	1	< 0.1	< 2	3
BZX55B7V5	7.35	7.65	< 7	< 50	5	0.03	0.07	1	< 0.1	< 2	5
BZX55B8V2	8.04	8.36	< 7	< 50	5	0.03	0.08	1	< 0.1	< 2	6.2
BZX55B9V1	8.92	9.28	< 10	< 50	5	0.03	0.09	1	< 0.1	< 2	6.8
BZX55B10	9.8	10.2	< 15	< 70	5	0.03	0.1	1	< 0.1	< 2	7.5
BZX55B11	10.78	11.22	< 20	< 70	5	0.03	0.11	1	< 0.1	< 2	8.2
BZX55B12	11.76	12.24	< 20	< 90	5	0.03	0.11	1	< 0.1	< 2	9.1
BZX55B13	12.74	13.26	< 26	< 110	5	0.03	0.11	1	< 0.1	< 2	10
BZX55B15	14.7	15.3	< 30	< 110	5	0.03	0.11	1	< 0.1	< 2	11
BZX55B16	15.7	16.3	< 40	< 170	5	0.03	0.11	1	< 0.1	< 2	12
BZX55B18	17.64	18.36	< 50	< 170	5	0.03	0.11	1	< 0.1	< 2	13
BZX55B20	19.6	20.4	< 55	< 220	5	0.03	0.11	1	< 0.1	< 2	15
BZX55B22	21.55	22.45	< 55	< 220	5	0.04	0.12	1	< 0.1	< 2	16
BZX55B24	23.5	24.5	< 80	< 220	5	0.04	0.12	1	< 0.1	< 2	18
BZX55B27	26.4	27.6	< 80	< 220	5	0.04	0.12	1	< 0.1	< 2	20
BZX55B30	29.4	30.6	< 80	< 220	5	0.04	0.12	1	< 0.1	< 2	22
BZX55B33	32.4	33.6	< 80	< 220	5	0.04	0.12	1	< 0.1	< 2	24
BZX55B36	35.3	36.7	< 80	< 220	5	0.04	0.12	1	< 0.1	< 2	27
BZX55B39	38.2	39.8	< 90	< 500	2.5	0.04	0.12	0.5	< 0.1	< 5	30
BZX55B43	42.1	43.9	< 90	< 600	2.5	0.04	0.12	0.5	< 0.1	< 5	33
BZX55B47	46.1	47.9	< 110	< 700	2.5	0.04	0.12	0.5	< 0.1	< 5	36
BZX55B51	50	52	< 125	< 700	2.5	0.04	0.12	0.5	< 0.1	< 10	39
BZX55B56	54.9	57.1	< 135	< 1000	2.5	0.04	0.12	0.5	< 0.1	< 10	43
BZX55B62	60.8	63.2	< 150	< 1000	2.5	0.04	0.12	0.5	< 0.1	< 10	47
BZX55B68	66.6	69.4	< 200	< 1000	2.5	0.04	0.12	0.5	< 0.1	< 10	51
BZX55B75	73	76.5	< 250	< 1500	2.5	0.04	0.12	0.5	< 0.1	< 10	56

Typical Characteristics

FIG1: Total Power Dissipation vs. Ambient Temperature

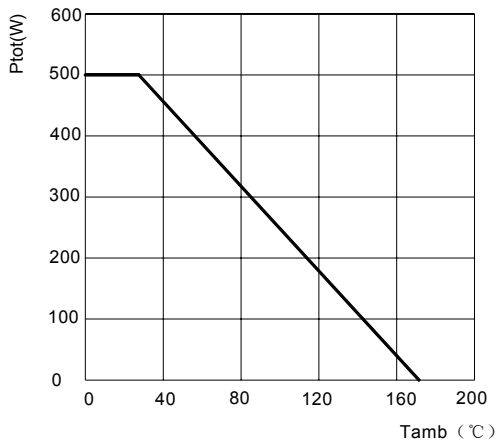

FIG2: Thermal Resistance vs. Lead Length

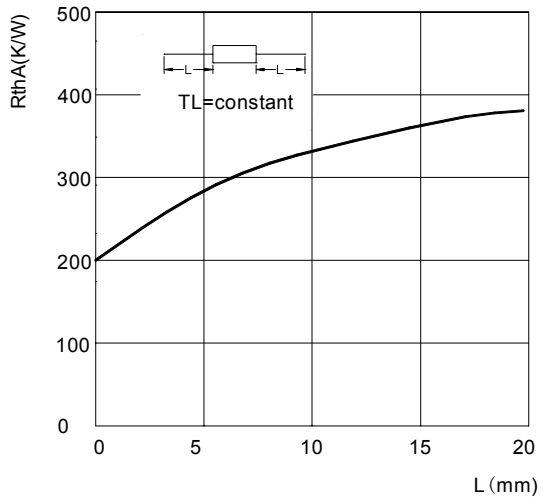

FIG3: Typical Change of Working Voltage under Operating Conditions at Tamb=25°C

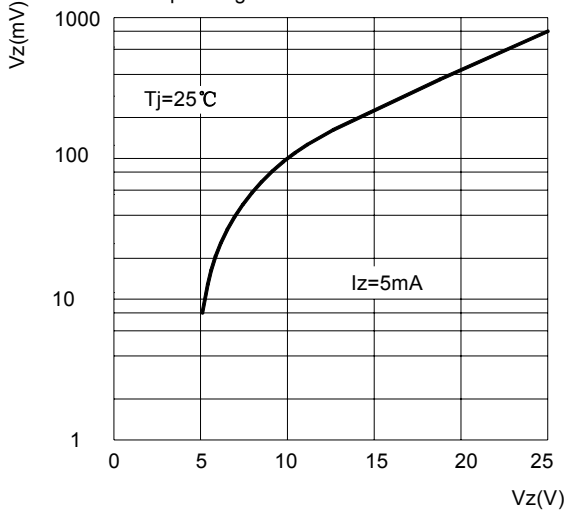

FIG4: Typical Change of Working Voltage vs. Junction Temperature

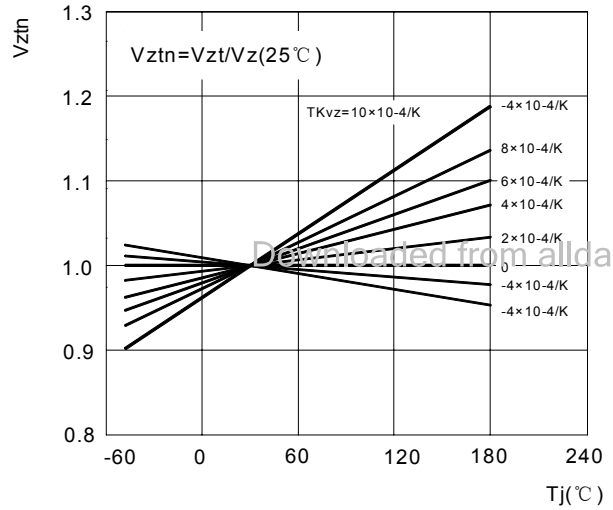

FIG5: Temperature Coefficient of Vz vs. Z-voltage

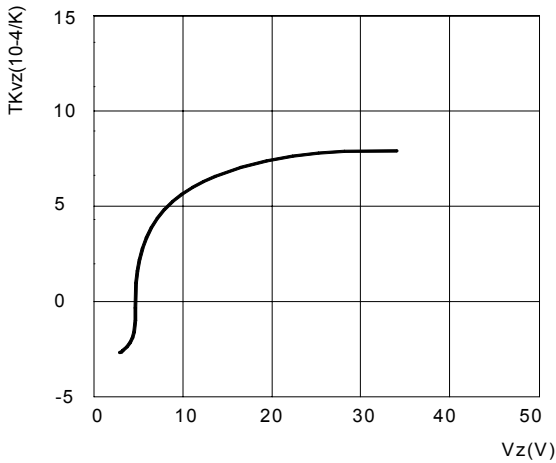
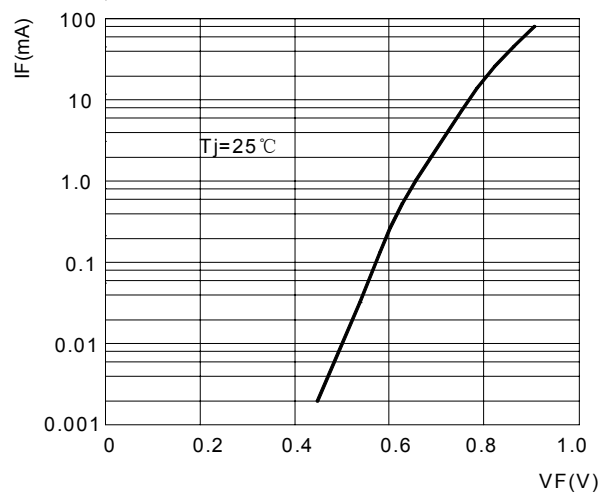
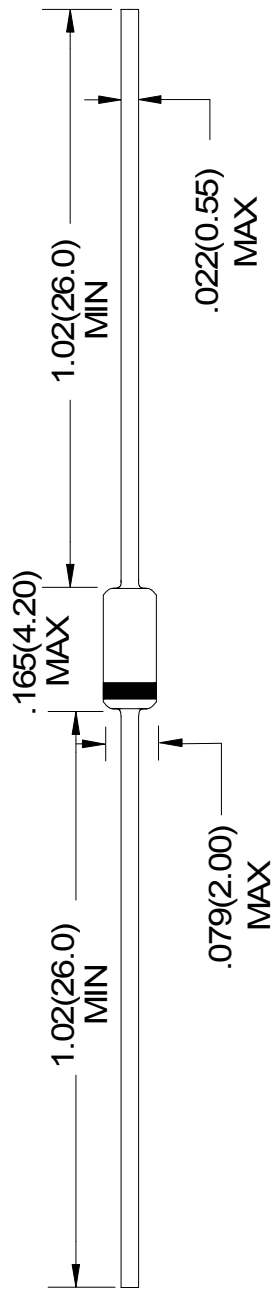

FIG6: Forward Current vs. Forward Voltage





Downloaded from alldatasheet.com

Unit: in inches (millimeters)

NOTICE

JSMD reserve the right to make modifications, enhancements, improvements, corrections or other changes without further notice to any product herein. JSMD does not assume any liability arising out of the application or use of any product described herein.

Ammo Box Packaging Specifications For Axial Lead Rectifiers

Axial lead devices are packed in accordance with EIA standard RS-296-D and specifications given below

COMPONENT OUTLINE	COMPONENT PITCH A	INNER TAPE PITCH B	CUMULATIVE PITCH TOLERANCE
	$\pm 0.5\text{mm}(.020'')$	$+0.5\text{mm}(.020'')$	
R-1	5.0mm	26.0mm	2.0mm/20pitch
R-1	5.0mm	52.4mm	2.0mm/10pitch
A-405	5.0mm	26.0mm	2.0mm/20pitch
A-405	5.0mm	52.4mm	2.0mm/10pitch
DO-34/DO-35	5.0mm	26.0mm	2.0mm/20pitch
DO-34/DO-35	5.0mm	52.4mm	2.0mm/10pitch
DO-41	5.0mm	26.0mm	2.0mm/20pitch
DO-41	5.0mm	52.4mm	2.0mm/10pitch
DO-15	5.0mm	52.4mm	2.0mm/10pitch
DO-27	10.0mm	52.4mm	2.0mm/10pitch
R-6	10.0mm	52.4mm	2.0mm/10pitch

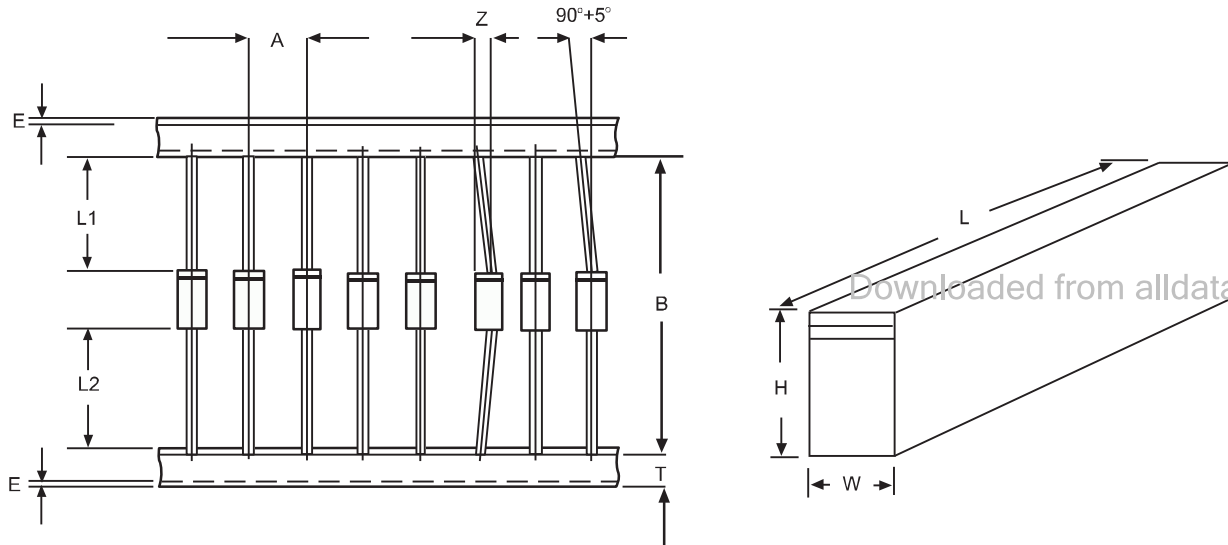

ITEM	SYMBOL	SPECIFICATIONS(mm)	SPECIFICATIONS(inch)
Component alignment	Z	1.2max	0.048max
Tape width	T	6.0 ± 0.4	0.236 ± 0.016
Exposed adhesive	E	0.8max	0.032max
Body eccentricity	$ L1-L2 $	1.0max	0.040max
Box length	L	255.0 ± 5.0	10.04 ± 0.197
Box width	W	78.0 ± 5.0	3.07 ± 0.197
Box height	H	150.0 ± 5.0	5.91 ± 0.197

NOTE: Each component lead shall be sandwiched between tapes for A minimum of 3.2mm(0.126'')