

C30617 and C30618 Series

High Speed InGaAs Pin Photodiodes

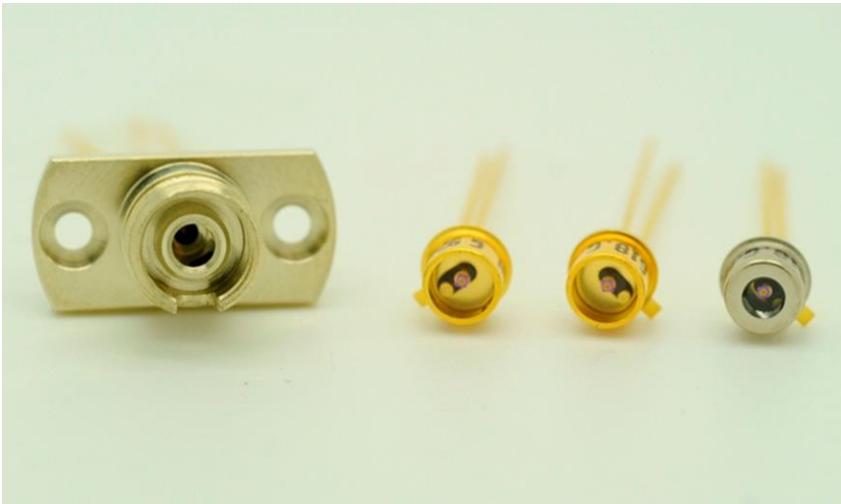

Overview

This series of high speed InGaAs photodiodes is designed for use in OEM fiber-optic communications systems and high-speed receiver applications including trunk line, LAN, fiber-in-the-loop and data communications. Ceramic sub-mount packages are available for easy integration into high speed SONET, FDDI, data link receiver modules, or as back facet power monitors in laser diode modules.

Available in hermetic TO-18 packages, in connectorized receptacle packages with industry standard FC or SC connectors, or in fibered TO-18 package, these photodiodes are designed to function with either single or multimode fibers. Receptacle packages use a ball-lens TO-18 package to maximize coupling efficiency. All devices are planar passivated and feature proven, high reliability mounting and contacting.

Recognizing that different applications have different performance requirements, Excelitas offers a wide range of customization of these photodiodes to meet your design challenges. Responsivity and noise screening, custom device testing and packaging are among many of the application-specific solutions available

Key Features

- Available in various packages
- 100, 350 μm diameters
- High responsivity at 1300 and 1500 nm
- Low capacitance for high bandwidths (to 3.5 GHz)

Applications

- Telecommunications
- Instrumentation
- Data transmission
- High speed switching
- Data links and LANs

C30617 and C30618 Series

High Speed InGaAs PIN Photodiodes

Table 1 – Mechanical and Optical Characteristics

	C30617	C30618	Unit
Shape	Circular	Circular	
Useful Area	0.008	0.096	mm ²
Useful Diameter	100	350	μm
Package Types¹	TO-18, Rectangular ceramic, FC, SC receptacle Pigtailed design	TO-18, Rectangular ceramic, FC receptacle	
Window Type	Ball Lens Glass	Flat Glass	

¹ See Figures 5 to 10 for package dimension details.

Table 2 – Ordering Guide

Package Type	C30617	C30618
TO-18 ball glass lens	C30617BH	
TO-18 flat glass lens	C30617GH	C30618GH
Rectangular ceramic	C30617ECERH	C30618ECERH
TO-18 ball lens with FC receptacle	C30617BFCH	C30618BFCH
TO-18 ball lens with SC receptacle	C30617BSCH	
Pigtailed design	C30617BQC-04-LC/FC (other fiber options available)	

Warranty

A standard 12-month warranty following shipment applies. Any warranty is null and void if the photodiode window has been opened.

C30617 and C30618 Series

High Speed InGaAs PIN Photodiodes

Table 4 – Electro-Optical Characteristics (C30617 , C30618)

$T_A = 22^\circ\text{C}$, @ $V_R = V_{op}$ typical (5V) unless otherwise stated

Parameter	Symbol	C30617			C30618			Unit
		Minimum	Typical	Maximum	Minimum	Typical	Maximum	
Operating Voltage	V_{op}		5			5		V
Breakdown Voltage	V_{br}	25	100		25	80		V
Responsivity at 1300 nm TO-18 ceramic FC/SC receptacle ¹		0.80 0.65	0.90 0.75		0.80 0.65	0.90 0.75		A/W
Responsivity at 1550 nm TO-18 ceramic FC/ SC receptacle ¹		0.85 0.70	0.95 0.80		0.85 0.70	0.95 0.80		A/W
Dark Current	i_d		<1.0	2.0		<1.0	5.0	nA
Spectral Noise Current (10KHz, 1.0 Hz)	i_n		<0.02	0.15		<0.02	0.20	pA/√Hz
Capacitance $V_R = 5V$ $V_R = 25V$	C		-- 0.45	1.0 --		-- 3.7	6.0 --	pF
Rise Time	t_r		0.07	0.5		0.5	1.0	ns
Fall Time	t_f		0.07	0.5		0.5	1.0	ns
Bandwidth (-3 _{dB} , $R_L = 50\Omega$)	BW		3.5			0.75		GHz
Maximum Forward Current				10			10	mA
Power Dissipation				100			100	mW
Storage Temperature ²		-60		125	-60		125	°C
Operating Temperature ²		-40		125	-40		125	°C

¹ Coupled from 62.5 μm , 0.28NA, graded index multi-mode fiber using 1300 nm SLED source.

² Maximum storage and operating temperature of connectorized/receptacle devices is +85°C.

High Speed InGaAs PIN Photodiodes

Figure 1 – Typical Quantum Efficiency as a function of Wavelength

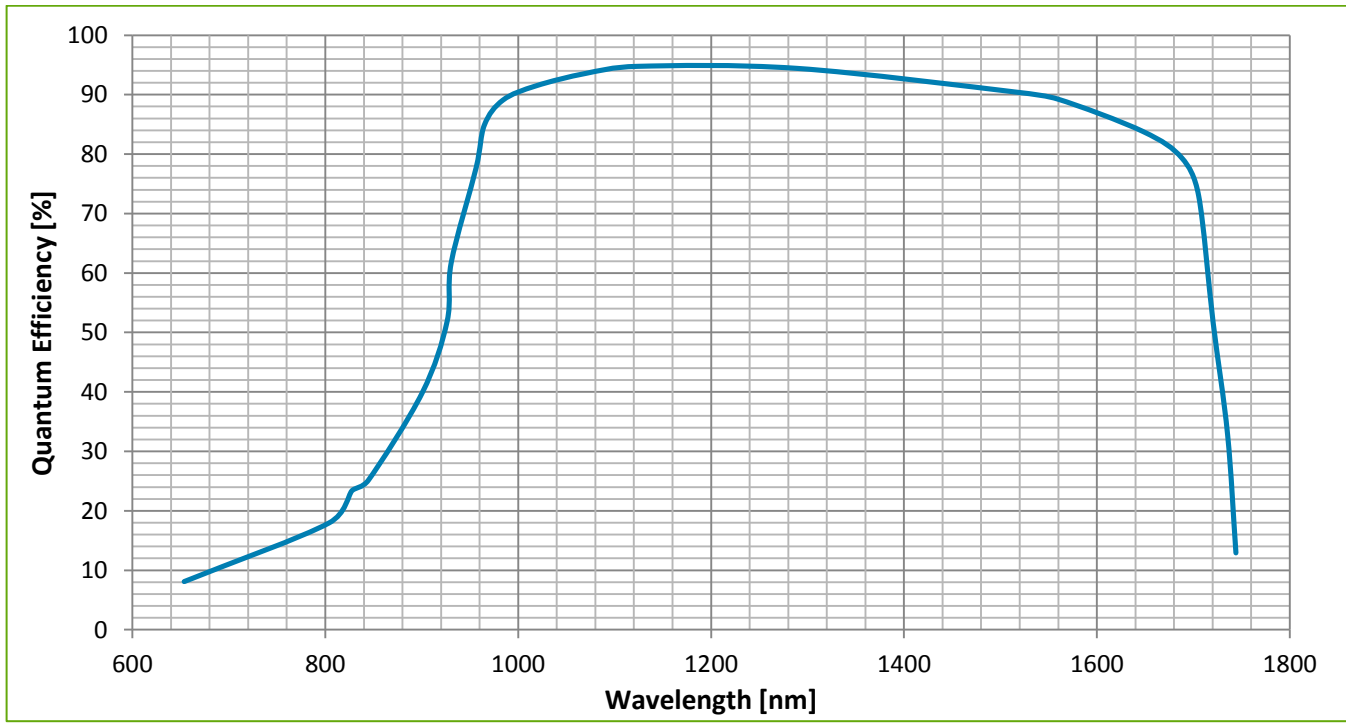
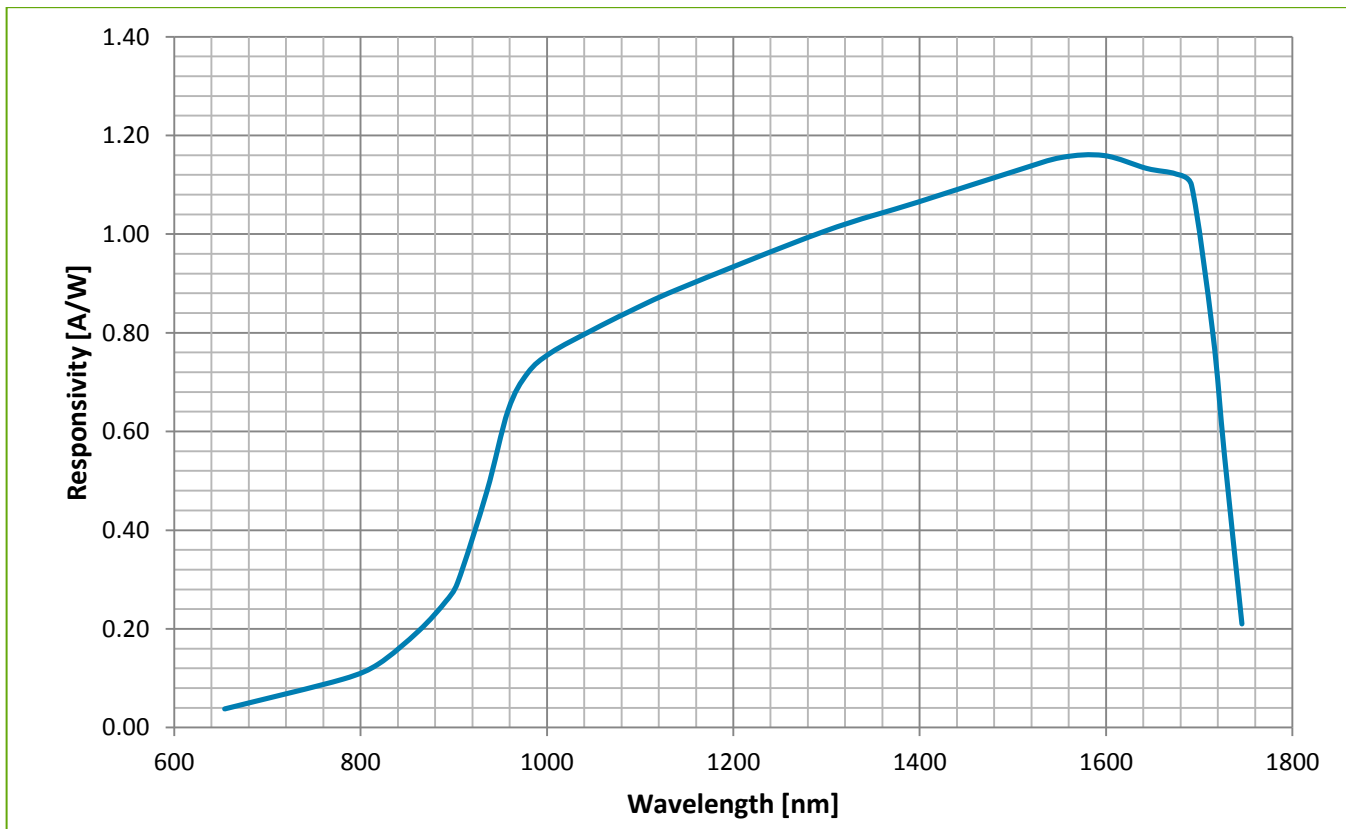

Figure 2 – Typical Responsivity as a function of Wavelength



C30617 and C30618 Series
High Speed InGaAs PIN Photodiodes

Figure 3 – Typical Capacitance as a function of Operating Voltage, V_{op}

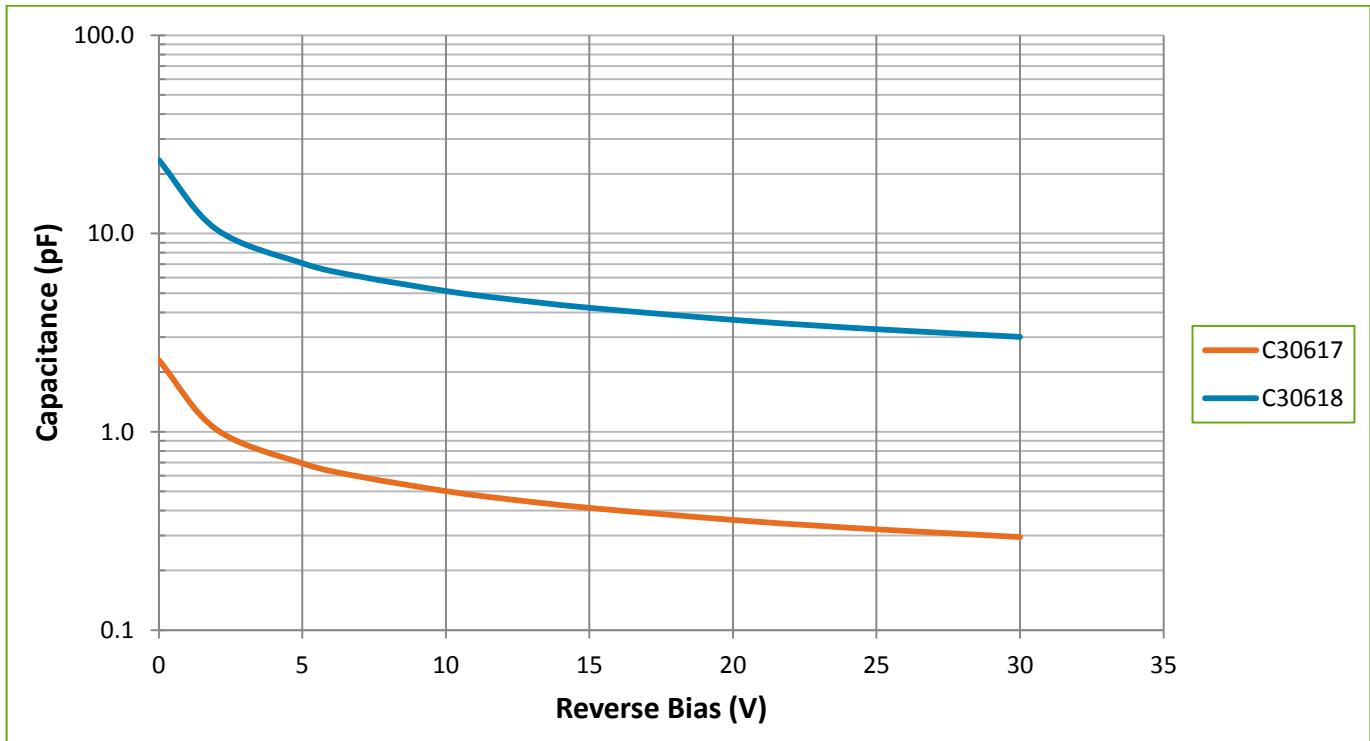
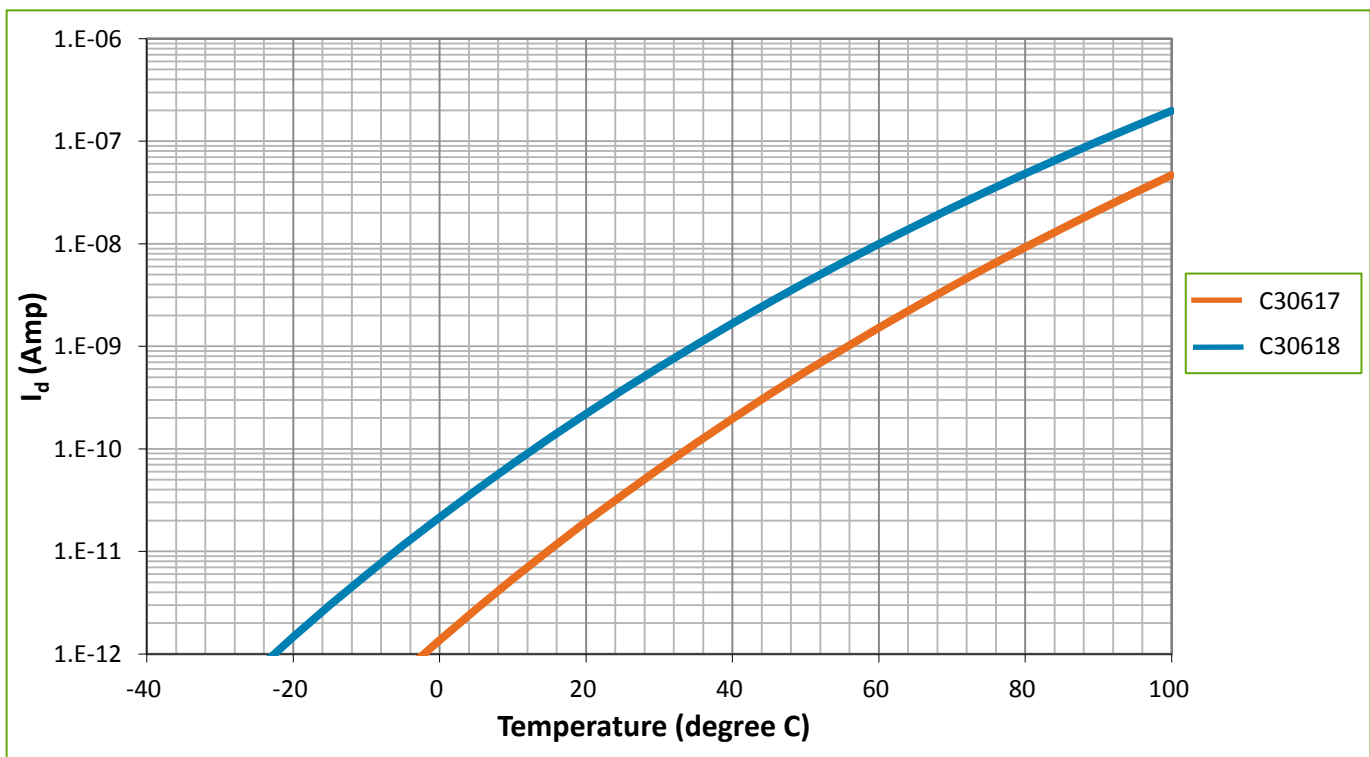

Figure 4 – Typical Dark Current as a function of Temperature



C30617 and C30618 Series
High Speed InGaAs PIN Photodiodes

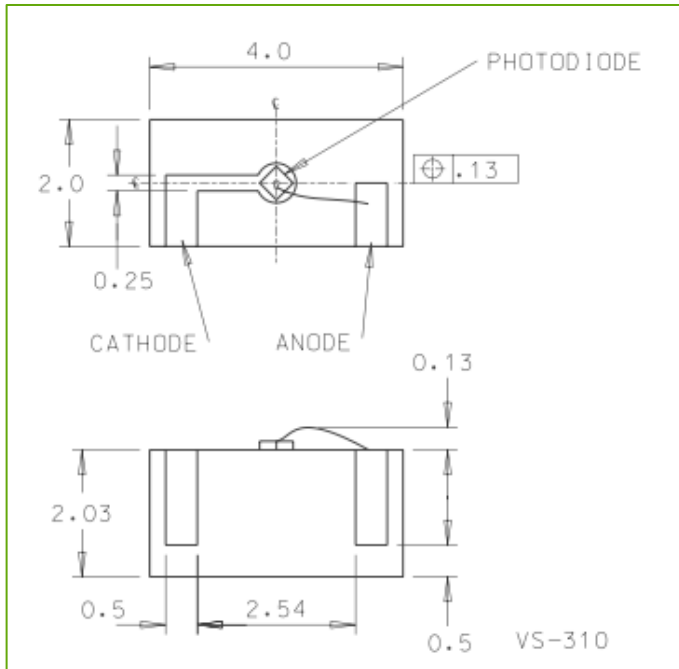

Figure 5 Package dimension for rectangular ceramic ECERH types, in mm, for reference only

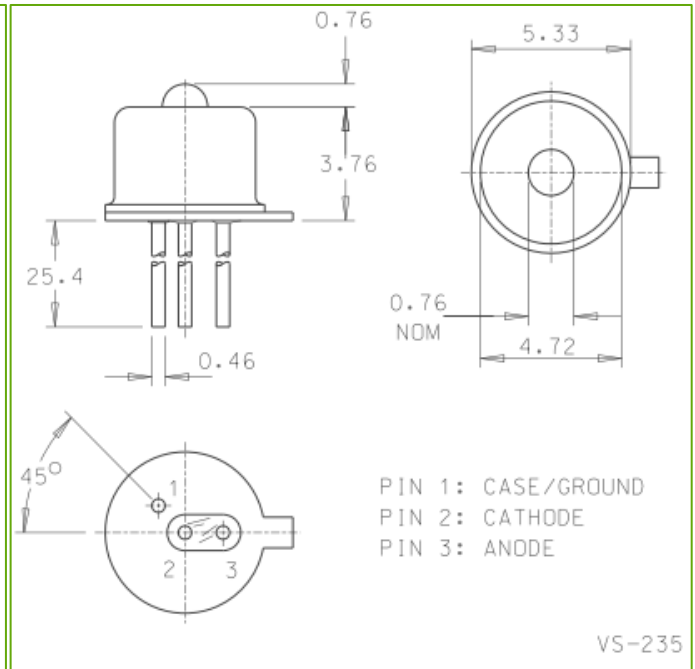

Figure 6 Package dimension for TO-18 ball lens BH types, in mm, for reference only

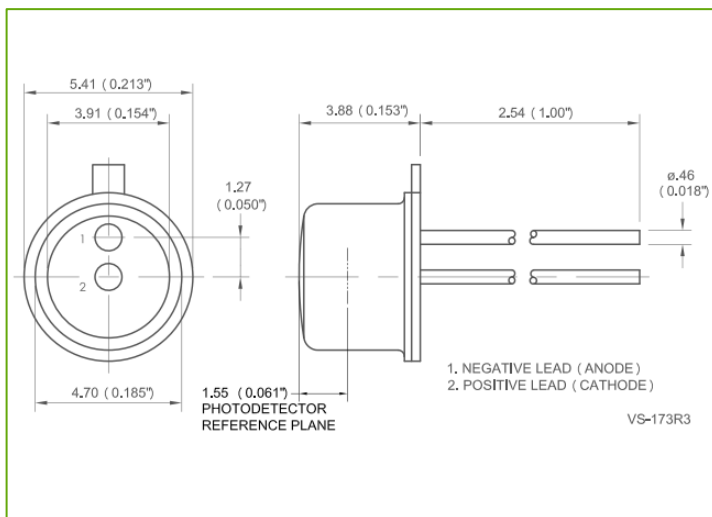

Figure 7 Package dimension for TO-18 flat glass lens GH types, in mm (inches), for reference only

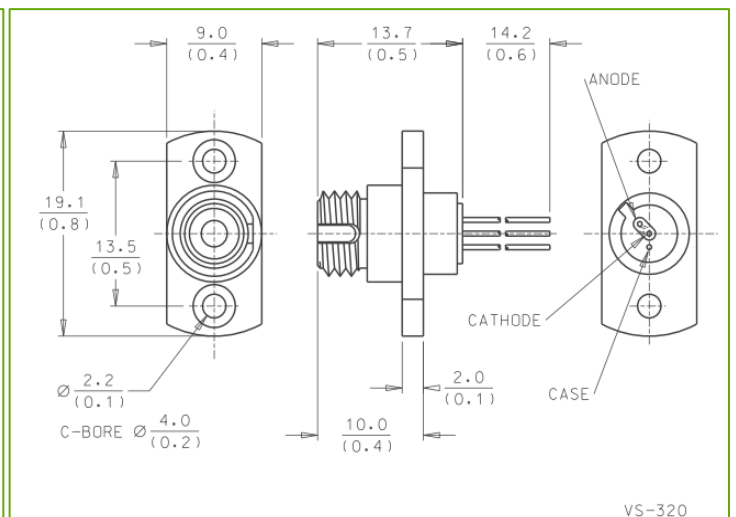

Figure 8 Package dimension for TO-18 ball lens FC receptacle BFC types, in mm (inches), for reference only

C30617 and C30618 Series

High Speed InGaAs PIN Photodiodes

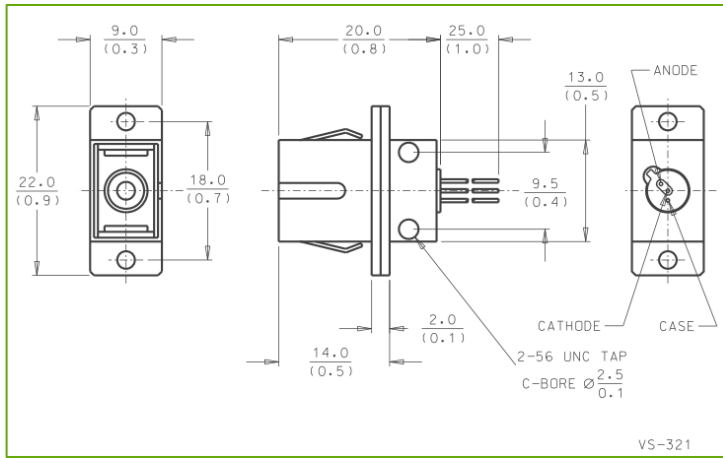

Figure 9 Package dimension for TO-18 ball lens SC receptacle BSC types, in mm (inches), for reference only

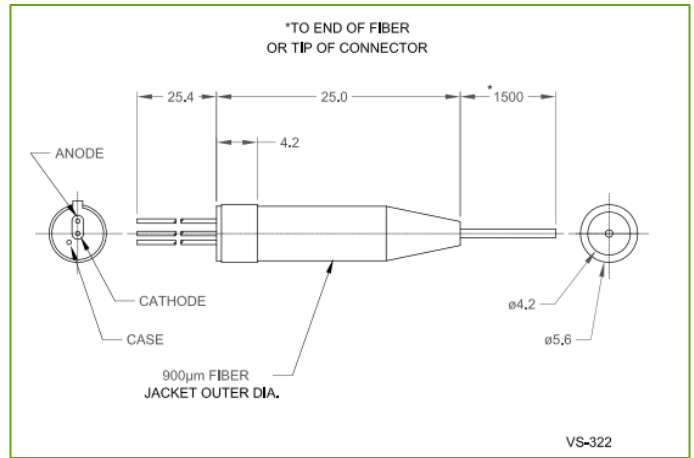

Figure 10 Package dimension for TO-18 ball lens fiber pigtail types, in mm (inches), for reference only

RoHS Compliance

These InGaAs PIN Photodiodes are designed and built to be fully compliant with the European Union Directive 2011/65/EU – Restriction of the use of certain Hazardous Substances (RoHS) in Electrical and Electronic equipment.



About Excelitas Technologies

Excelitas Technologies is a global technology leader focused on delivering innovative, customized solutions to meet the lighting, detection and other high-performance technology needs of OEM customers.

Excelitas has a long and rich history of serving our OEM customer base with optoelectronic sensors and modules for more than 45 years beginning with PerkinElmer, EG&G, and RCA. The constant throughout has been our innovation and commitment to delivering the highest quality solutions to our customers worldwide.

From aerospace and defense to analytical instrumentation, clinical diagnostics, medical, industrial, and safety and security applications, Excelitas Technologies is committed to enabling our customers' success in their specialty end-markets. Excelitas Technologies has approximately 5,000 employees in North America, Europe and Asia, serving customers across the world.

Excelitas Technologies
22001 Dumberry Road
Vaudreuil-Dorion, Quebec
Canada J7V 8P7
Telephone: (+1) 450 424 3300
Toll-free: (+1) 800 775 6786
Fax: (+1) 450 424 3345
detection@excelitas.com

**Excelitas Technologies
GmbH & Co. KG**
Wenzel-Jaksch-Str. 31
D-65199 Wiesbaden
Germany
Telephone: (+49) 611 492 430
Fax: (+49) 611 492 165
detection.europe@excelitas.com

Excelitas Technologies Singapore, Pte. Ltd.
8 Tractor Road
Singapore 627969
Telephone: (+65) 6775 2022 (Main number)
Telephone: (+65) 6770 4366 (Customer Service)
Fax: (+65) 6778-1752
detection.asia@excelitas.com

EXCELITAS®
TECHNOLOGIES

For a complete listing of our global offices, visit www.excelitas.com/locations

© 2015 Excelitas Technologies Corp. All rights reserved. The Excelitas logo and design are registered trademarks of Excelitas Technologies Corp. All other trademarks not owned by Excelitas Technologies or its subsidiaries that are depicted herein are the property of their respective owners. Excelitas reserves the right to change this document at any time without notice and disclaims liability for editorial, pictorial or typographical errors.