

December 1993

## A/D Converter for 3-Digit Display

### Features

- Dual Slope A/D Conversion
- Multiplexed BCD Display
- Ultra Stable Internal Band Gap Voltage Reference
- Capable of Reading 99mV Below Ground with Single Supply
- Differential Input
- Internal Timing - No External Clock Required
- Choice of Low Speed (4Hz) or High Speed (96Hz) Conversion Rate
- "Hold" Inhibits Conversion but Maintains Delay
- Overrange Indication
  - "EEE" for Reading Greater than +999mV, "-" for Reading More Negative than -99mV When Used With CA3161E
- BCD-to-Seven-Segment Decoder/Driver
- Extended Temperature Range Version Available

### Description

The CA3162E and CA3162AE are  $I^2L$  monolithic A/D converters that provide a 3 digit multiplexed BCD output. They are used with the CA3161E BCD-to-Seven-Segment Decoder/Driver\* and a minimum of external parts to implement a complete 3 digit display. The CA3162AE is identical to the CA3162E except for an extended operating temperature range.

\* The CA3161E is described in Display Drivers section of this data book.

### Ordering Information

PART NUMBER	TEMPERATURE RANGE	PACKAGE
CA3162E	0°C to +70°C	16 Lead Plastic DIP
CA3162AE	-40°C to +85°C	16 Lead Plastic DIP

### Pinout

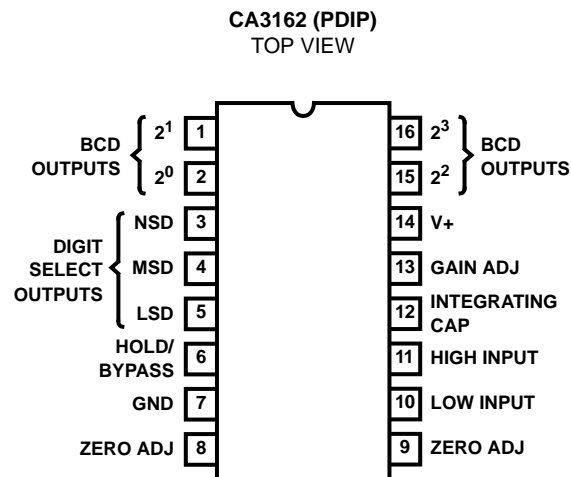

CA3162, CA3162A

Functional Block Diagram

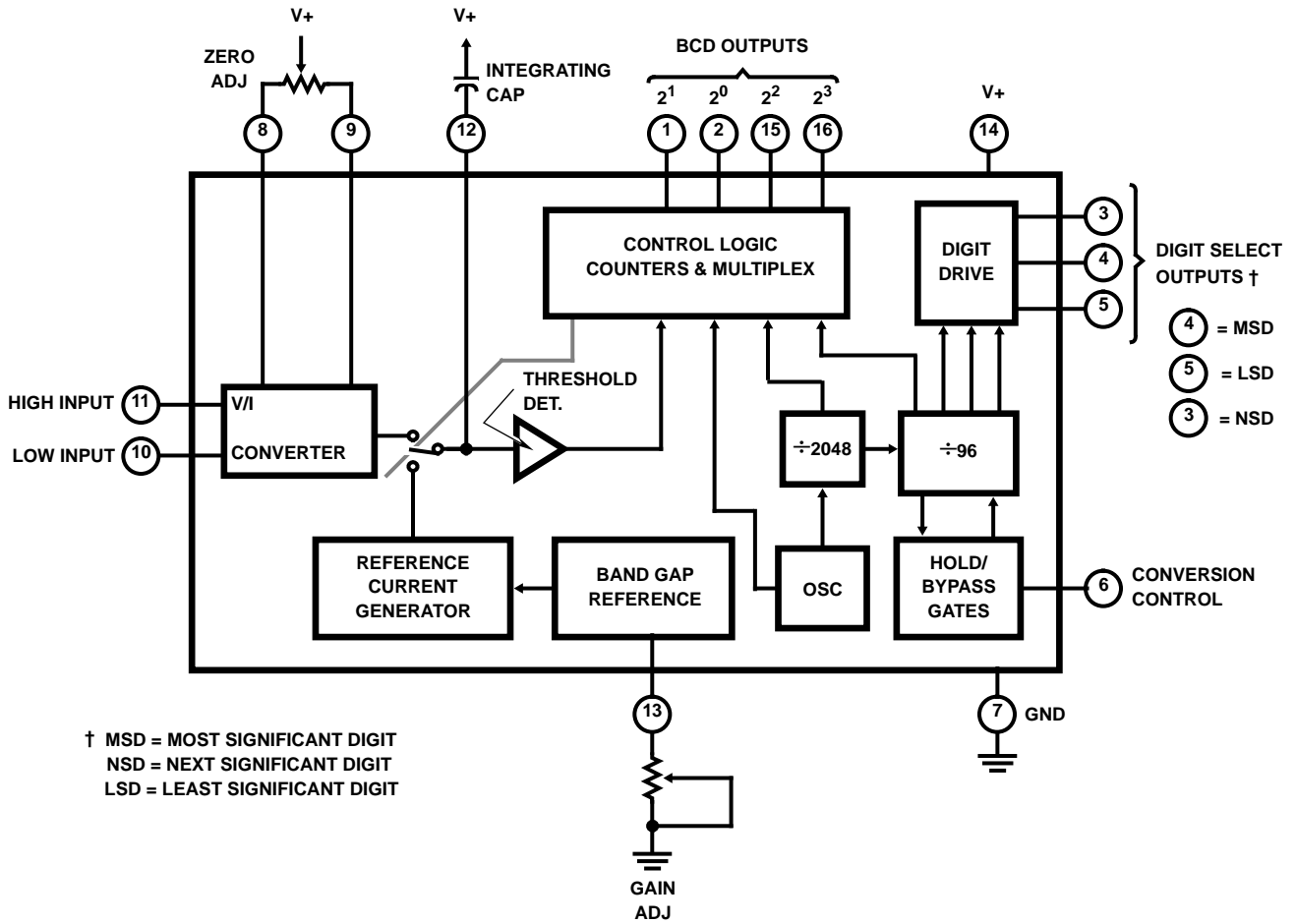

## Specifications CA3162, CA3162A

### Absolute Maximum Ratings

DC Supply Voltage (Between Pins 7 & 14) . . . . . +7V  
 Input Voltage (Pin 10 or 11 to Ground) . . . . .  $\pm 15V$   
 Storage Temperature Range . . . . .  $-65^{\circ}C$  to  $+150^{\circ}C$   
 Lead Temperature (Soldering 10s) . . . . .  $+300^{\circ}C$

### Thermal Information

Thermal Resistance  $\theta_{JA}$   
 Plastic DIP Package . . . . .  $90^{\circ}C/W$   
 Operating Temperature Range  
 CA3162E . . . . .  $0$  to  $+75^{\circ}C$   
 CA3162AE . . . . .  $-40^{\circ}C$  to  $+85^{\circ}C$   
 Maximum Power Dissipation  
 Plastic DIP Package . . . . .  $0.67W$   
 Junction Temperature . . . . .  $+150^{\circ}C$

*CAUTION: Stresses above those listed in "Absolute Maximum Ratings" may cause permanent damage to the device. This is a stress only rating and operation of the device at these or any other conditions above those indicated in the operational sections of this specification is not implied.*

### Electrical Specifications $T_A = +25^{\circ}C$ , $V_+ = 5V$ , Zero Pot Centered, Gain Pot = $2.4k\Omega$ Unless Otherwise Specified

PARAMETERS	TEST CONDITIONS	MIN	TYP	MAX	UNITS
Operating Supply Voltage Range, $V_+$		4.5	5	5.5	V
Supply Current, $I_+$	100k $\Omega$ to $V_+$ on Pins 3, 4, 5	-	-	17	mA
Input Impedance, $Z_I$		-	100	-	M $\Omega$
Input Bias Current, $I_{IB}$	Pins 10 and 11	-	-80	-	nA
Unadjusted Zero Offset	$V_{11}-V_{10} = 0V$ , Read Decoded Output	-12	-	+12	mV
Unadjusted Gain	$V_{11}-V_{10} = 900mV$ , Read Decoded Output	846	-	954	mV
Linearity	Notes 1 and 2	-1	-	+1	Count
Conversion Rate					
Slow Mode	Pin 6 = Open or GND	-	4	-	Hz
Fast Mode	Pin 6 = 5V	-	96	-	Hz
Conversion Control Voltage (Hold Mode) at Pin 6		0.8	1.2	1.6	V
Common Mode Input Voltage Range, $V_{ICR}$	Notes 3, 4	-0.2	-	+0.2	V
BCD Sink Current at Pins 1, 2, 15, 16	$V_{BCD} \geq 0.5V$ , at Logic Zero State	0.4	1.6	-	mA
Digit Select Sink Current at Pins 3, 4, 5	$V_{DIGIT\ Select} = 4V$ at Logic Zero State	1.6	2.5	-	mA
Zero Temperature Coefficient	$V_I = 0V$ , Zero Pot Centered	-	10	-	$\mu V/^{\circ}C$
Gain Temperature Coefficient	$V_I = 900mV$ , Gain Pot = $2.4k\Omega$	-	0.005	-	$\%/^{\circ}C$

#### NOTES:

- Apply zero volts across  $V_{11}$  to  $V_{10}$ . Adjust zero potentiometer to give 000mV reading. Apply 900mV to input and adjust gain potentiometer to give 900mV reading.
- Linearity is measured as a difference from a straight line drawn through zero and positive full scale. Limits do not include  $\pm 0.5$  count bit digitizing error.
- For applications where low input pin 10 is not operated at pin 7 potential, a return path of not more than 100k $\Omega$  resistance must be provided for input bias currents.
- The common mode input voltage above ground cannot exceed +0.2V if the full input signal range of 999mV is required at pin 11. That is, pin 11 may not operate higher than 1.2V positive with respect to ground or 0.2V negative with respect to ground. If the maximum input signal is less than 999mV, the common mode input voltage may be raised accordingly.

Timing Diagram

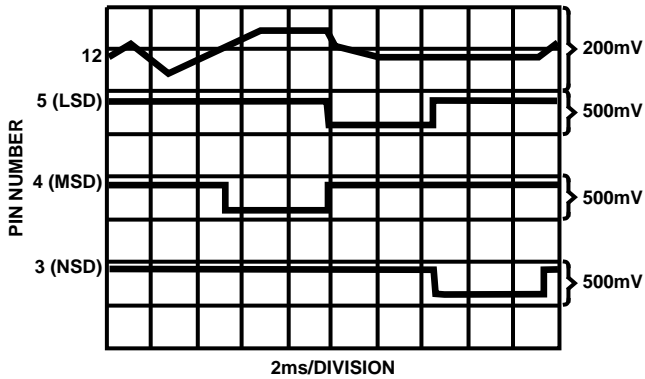

FIGURE 1. HIGH SPEED MODE

Detailed Description

The Functional Block Diagram of the CA3162E shows the V/I converter and reference current generator, which is the heart of the system. The V/I converter converts the input voltage applied between pins 10 and 11 to a current that charges the integrating capacitor on pin 12 for a predetermined time interval. At the end of the charging interval, the V/I converter is disconnected from the integrating capacitor, and a band gap

reference constant current source of opposite polarity is connected. The number of clock counts that elapse before the charge is restored to its original value is a direct measure of the signal induced current. The restoration is sensed by the comparator, which in turn latches the counter. The count is then multiplexed to the BCD outputs.

The timing for the CA3162E is supplied by a 786Hz ring oscillator, and the input at pin 6 determines the sampling rate. A 5V input provides a high speed sampling rate (96Hz), and grounding or floating pin 6 provides a low speed (4Hz) sampling rate. When pin 6 is fixed at +1.2V (by placing a 12K resistor between pin 6 and the +5V supply) a "hold" feature is available. While the CA3162E is in the hold mode, sampling continues at 4Hz but the display data are latched to the last reading prior to the application of the 1.2V. Removal of the 1.2V restores continuous display changes. Note, however, that the sampling rate remains at 4Hz.

Figure 1 shows the timing of sampling and digit select pulses for the high speed mode. Note that the basic A/D conversion process requires approximately 5ms in both modes.

The "EEE" or "---" displays indicate that the range of the system has been exceeded in the positive or negative direction, respectively. Negative voltages to -99mV are displayed with the minus sign in the MSD. The BCD code is 1010 for a negative overrange (---) and 1011 for a positive overrange (EEE).

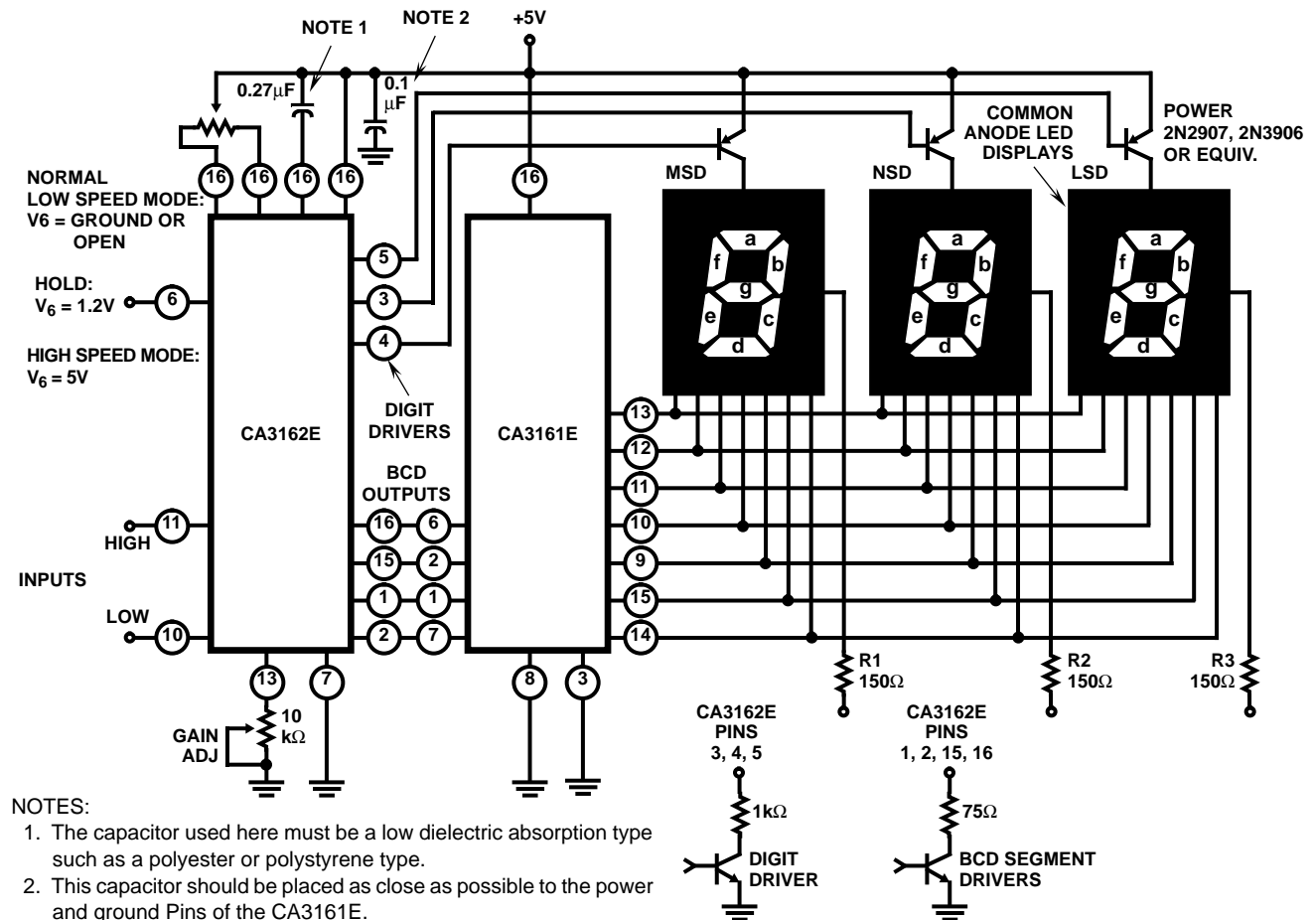

FIGURE 2. BASIC DIGITAL READOUT SYSTEM USING THE CA3162E AND THE CA3161E





# CA3162, CA3162A

## Die Characteristics

### DIE DIMENSIONS:

101 x 124 x 20 ± 1mils

### METALLIZATION:

Type: Al

Thickness: 17.5kÅ ± 2.5kÅ

### GLASSIVATION:

Type: 3% PSG

Thickness: 13kÅ ± 2.5kÅ

## Metallization Mask Layout

CA3162, CA3162A

