

April 1994

## Dual Full Bridge Driver

### Features

- Two Full Bridge Drivers
- $\pm 150\text{mA}$  Maximum Current
- Logic Controlled Switching
- Direction Control
- PWM  $I_{\text{OUT}}$  Control
- 18V Over-Voltage Protection
- 300mA Short-Circuit Protection
- Nominal 8V to 16V Operation
- Internal Voltage Regulation With Bandgap Reference

### Applications

- Dual Full Bridge Driver For Air Core Gauge Instrumentation
- $\mu\text{P}$  Controlled Sensor Data Displays
- Speedometer Displays
- Tachometer Displays
- Stepper Motors
- Slave Position Indicators

### Description

The CA3275 Dual Full Bridge Driver is intended for general-purpose applications requiring Dual Full Bridge drive or switching, including direction and pulse-width modulation for position control. While all features of the IC may not be utilized or required, they would normally be used in instrumentation systems with quadrature coils, such as air-core gauges, where the coils would be driven at frequencies ranging from 200Hz to 400Hz. The coils are wrapped at 90° angles for independent direction control. Coils wound in this physical configuration are controlled by pulse width modulation, where each coil drive is a function of the sine or cosine versus degrees of movement. The direction control is used to change the direction of the current in the H-Driver coil.

The switch rate capability of the IC is typically 30kHz regardless of the inductive load. Over-current limiting is used to limit short circuit current. Over-voltage protection (in the range of 18V to 24V) causes the device to shut down the output current drive. Thermal shutdown limits power dissipation on the chip. The CA3275 is supplied in a 14 lead dual-in-line plastic package.

### Ordering Information

PART NO.	TEMPERATURE	PACKAGE
CA3275E	-40°C to +85°C	14 Lead Plastic DIP

### Pinout

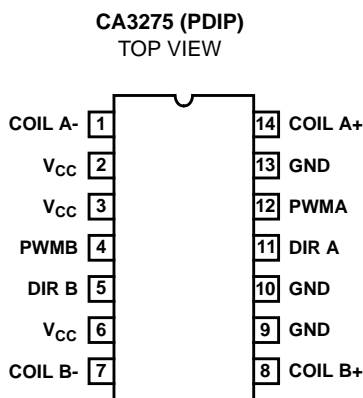

### Block Diagram

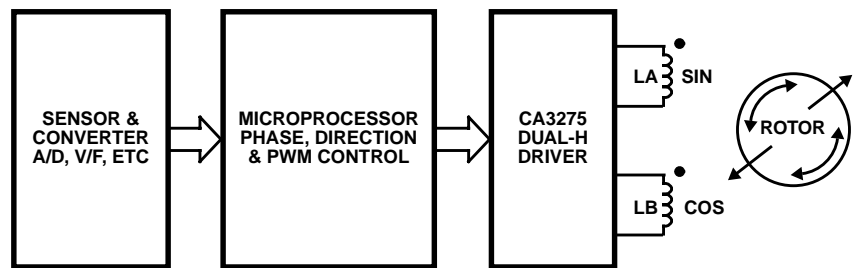

# Specifications CA3275

## Absolute Maximum Ratings

Operating $V_{CC}$ .....	16V
Transient $V_{CC}$ , 30 Seconds Maximum .....	24V
Peak $V_{CC}$ , 0.4 Seconds Maximum .....	40V
Maximum Continuous Output Current, .....	$\pm 100$ mA
Each Drive	
Maximum PWM Output Switching Current, .....	$\pm 150$ mA
Each Drive	

## Thermal Information

Thermal Resistance	$\theta_{JA}$
PDIP Package .....	100°C/W
Power Dissipation, $P_D$	
Up to +70°C .....	800mW
Above +70°C .....	Derate Linearly at 10mW/°C
Ambient Temperature Range	
Operating .....	-40°C to +85°C
Storage .....	-55°C to +150°C
Lead Temperature (During Soldering) .....	+265°C
At distance 1/16" $\pm$ 1/32" (1.59 $\pm$ 0.79mm) from case for	10s max

*CAUTION: Stresses above those listed in "Absolute Maximum Ratings" may cause permanent damage to the device. This is a stress only rating and operation of the device at these or any other conditions above those indicated in the operational sections of this specification is not implied.*

## Electrical Specifications $T_A = -40^\circ\text{C}$ to $+85^\circ\text{C}$ , $V_{CC} = 16\text{V}$ Unless Otherwise Specified

PARAMETERS	SYMBOL	MIN	TYP	MAX	UNITS
Operating Supply Voltage Range	$V_{CC}$	8	-	16	V
Supply Current (Note 1)	$I_{CC}$	-	8	20	mA
INPUT LEVELS					
Logic Input, Low Voltage	$V_{IL}$	-	-	0.8	V
Logic Input, High Voltage	$V_{IH}$	3.5	-	-	V
Logic Input, Low Current, $V_{IL} = 0\text{V}$	$I_{IL}$	-10	-	-	$\mu\text{A}$
Logic Input, High Current, $V_{IH} = 5\text{V}$	$I_{IH}$	-	-	10	$\mu\text{A}$
OUTPUT: $R_{LA} = R_{LB} = 138\Omega$					
Maximum Source Saturated Voltage	$V_{SAT} - \text{High}$	-	1.2	1.75	V
Maximum Sink Saturated Voltage	$V_{SAT} - \text{Low}$	-	0.25	0.5	V
Differential $V_{SAT}$ Voltage, Both Outputs Saturated	Diff - $V_{SAT}$	-	10	100	mV

## Switching Specifications

PARAMETERS	SYMBOL	MIN	TYP	MAX	UNITS
SOURCE CURRENT (See Figure 3)					
Turn-Off Delay	$T_{SC-OFF}$	-	-	2	$\mu\text{s}$
Fall Time	$T_{SC-F}$	-	-	2.2	$\mu\text{s}$
Turn-On Time	$T_{SC-ON}$	-	-	1	$\mu\text{s}$
Rise Time	$T_{SC-R}$	-	-	0.4	$\mu\text{s}$
SINK CURRENT (See Figure 4)					
Turn-Off Delay	$T_{SK-OFF}$	-	-	1.6	$\mu\text{s}$
Fall Time	$T_{SK-F}$	-	-	0.4	$\mu\text{s}$
Turn-On Time	$T_{SK-ON}$	-	-	0.6	$\mu\text{s}$
Rise Time	$T_{SK-R}$	-	-	0.2	$\mu\text{s}$

**NOTE:**

- No load,  $PWMA = PWMB = 5\text{V}$ ,  $DIR A = DIR B = 0\text{V}$

# CA3275

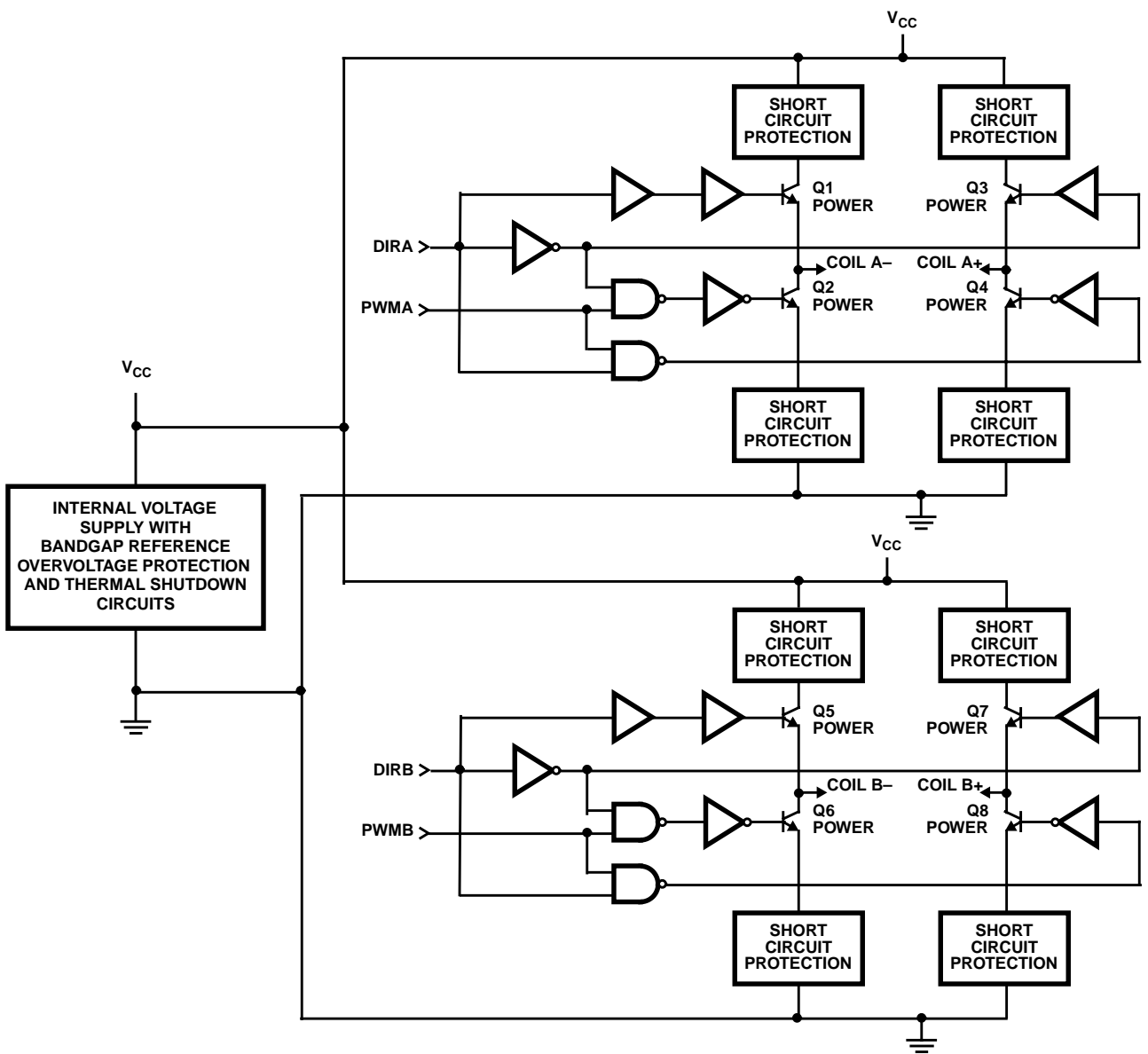

FIGURE 1. CA3275 DUAL FULL BRIDGE DRIVER SCHEMATIC

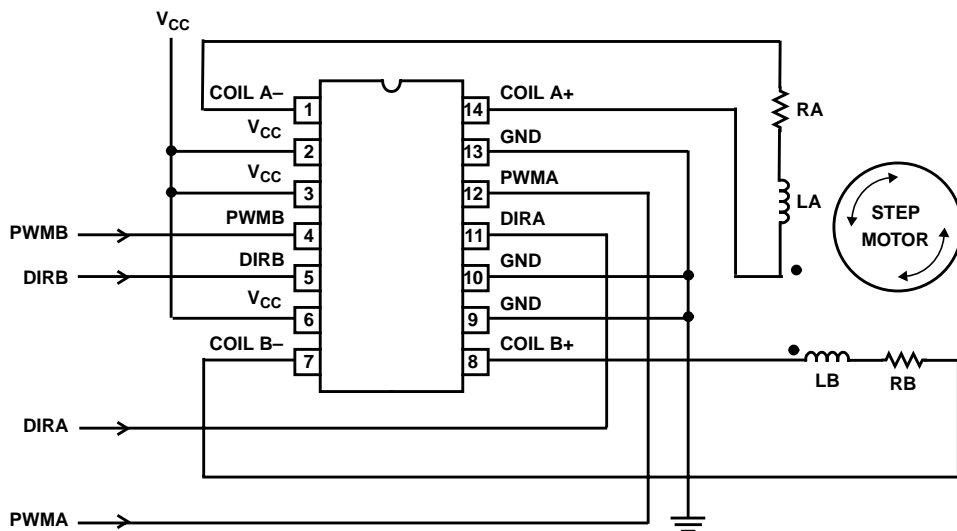

FIGURE 2. QUADRATURE STEP-MOTOR APPLICATION SCHEMATIC

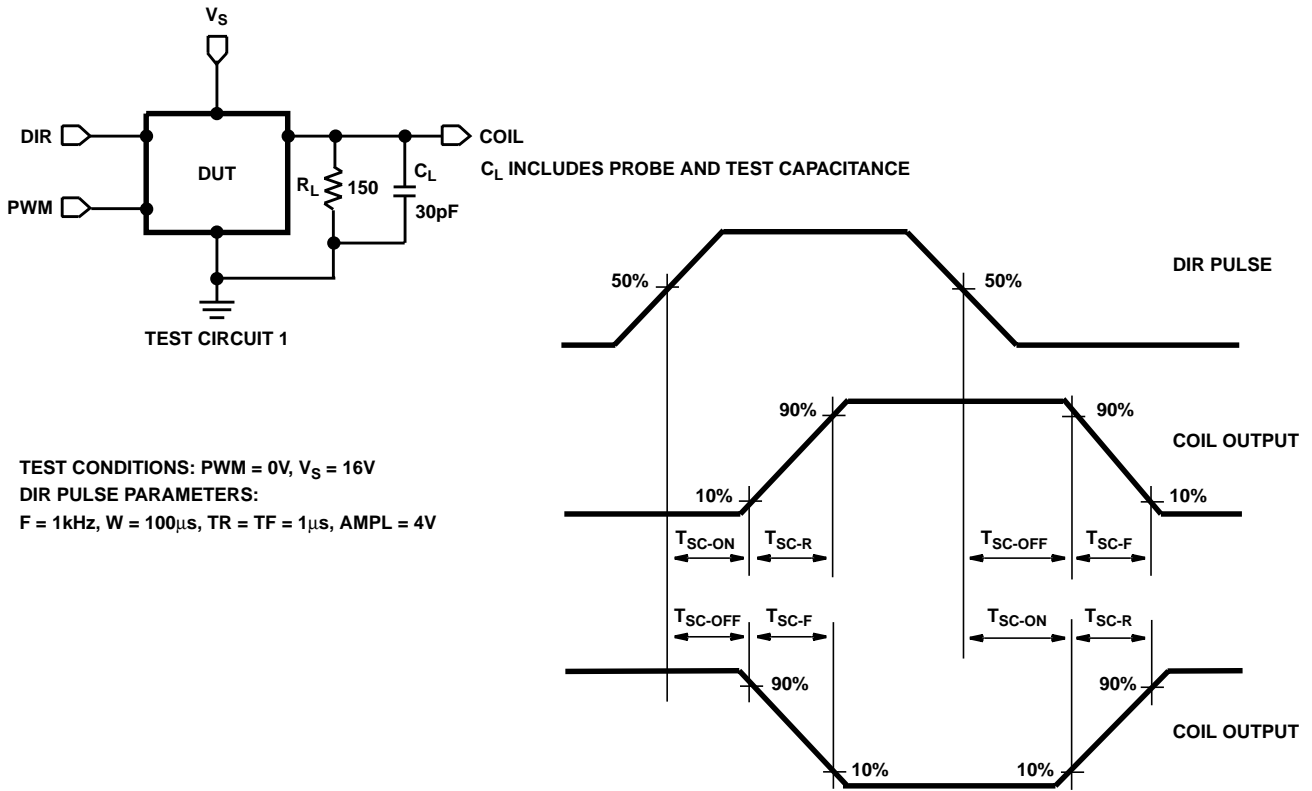

FIGURE 3. SOURCE SWITCHING TEST CIRCUIT AND VOLTAGE WAVEFORMS

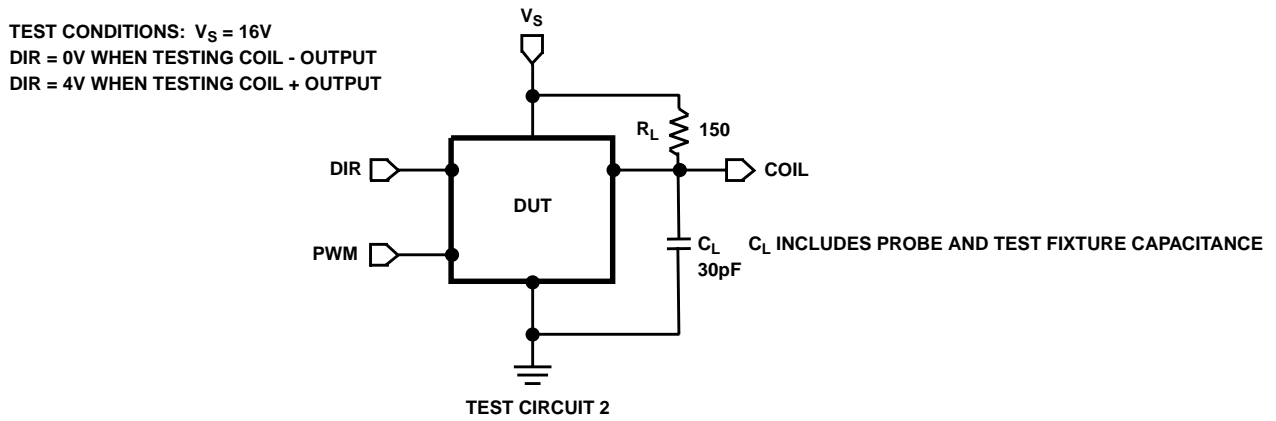

FIGURE 4. SINK SWITCHING TEST CIRCUIT AND VOLTAGE WAVEFORMS

All Intersil semiconductor products are manufactured, assembled and tested under **ISO9000** quality systems certification.

*Intersil products are sold by description only. Intersil Corporation reserves the right to make changes in circuit design and/or specifications at any time without notice. Accordingly, the reader is cautioned to verify that data sheets are current before placing orders. Information furnished by Intersil is believed to be accurate and reliable. However, no responsibility is assumed by Intersil or its subsidiaries for its use; nor for any infringements of patents or other rights of third parties which may result from its use. No license is granted by implication or otherwise under any patent or patent rights of Intersil or its subsidiaries.*

For information regarding Intersil Corporation and its products, see web site <http://www.intersil.com>

### **Sales Office Headquarters**

#### **NORTH AMERICA**

Intersil Corporation  
P. O. Box 883, Mail Stop 53-204  
Melbourne, FL 32902  
TEL: (321) 727-9207  
FAX: (321) 724-7240

#### **EUROPE**

Intersil SA  
Mercure Center  
100, Rue de la Fusee  
1130 Brussels, Belgium  
TEL: (32) 2.724.2111  
FAX: (32) 2.724.22.05

#### **ASIA**

Intersil (Taiwan) Ltd.  
Taiwan Limited  
7F-6, No. 101 Fu Hsing North Road  
Taipei, Taiwan  
Republic of China  
TEL: (886) 2 2716 9310  
FAX: (886) 2 2715 3029