

CFK2062-P3

1.8 to 2.0 GHz
+30 dBm Power GaAs FET

Product Specifications
July 1997 (1 of 4)

1.8 to 2.0 GHz +30 dBm Power GaAs FET

Features

- ❑ High Gain
- ❑ +30 dBm Power Output
- ❑ Proprietary Power FET Process
- ❑ >40% Linear Power Added Efficiency
- ❑ Surface Mount SO-8 Power Package

Applications

- ❑ PCS/PCN Base Stations and Terminals
- ❑ Wireless Local Loop

Description

The CFK2062-P3 is a high-gain FET intended for driver amplifier applications in high-power systems, and output stage usage in medium power applications at power levels up to +30 dBm. The device is easily matched and provides excellent linearity at 1 Watt. Manufactured in Celeritek's proprietary

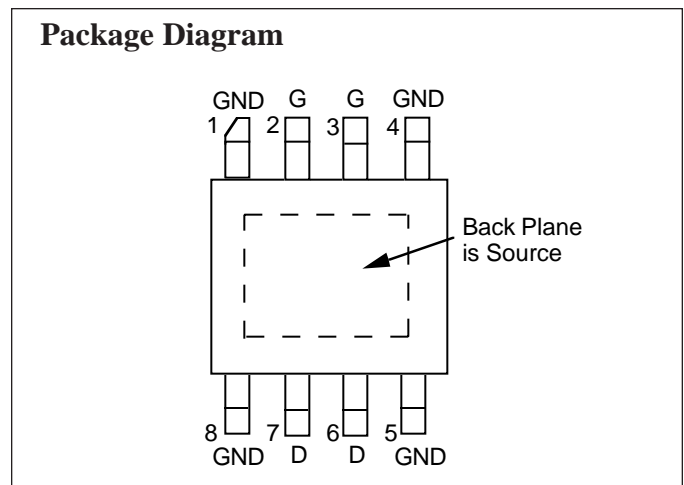

power FET process, this device is assembled in an industry standard surface mount SO-8 power package that is compatible with high volume, automated board assembly techniques.

Specifications (TA = 25°C) The following specifications are guaranteed at room temperature in Celeritek test fixture at 1.95 GHz.

Parameters	Conditions	Min	Typ	Max	Units
V_d = 8V, I_d = 400 mA (Quiescent)					
P-1dB		30.0	31.0	—	dBm
SSG		13.5	14.5	—	dB
3rd Order Products (1)		—	30	—	dBc
Efficiency	@ P1dB	—	40	—	%
V_d = 5V, I_d = 600 mA (Quiescent)					
P-1dB		—	30.5	—	dBm
SSG		—	13.5	—	dB

Parameters	Conditions	Min	Typ	Max	Units
g _m	V _{ds} = 2.0V, V _{gs} = 0V	—	650	—	mS
I _{dss}	V _{ds} = 2.0V, V _{gs} = 0V	—	1.4	—	A
V _p	V _{ds} = 3.0V, I _{ds} = 25 mA	—	-1.8	—	Volts
BV _{GD}	I _{gd} = 2.5 mA	15	17	—	Volts
Θ _{JL} (2)	@ 150°C TCH	—	12	—	°C/W

Absolute Maximum Ratings

Parameter	Symbol	Rating
Drain-Source Voltage	V _{DS}	10V (3)
Gate-Source Voltage	V _{GS}	-5V
Drain Current	I _{DS}	I _{dss}
Continuous Dissipation	P _T	6W
Channel Temperature	T _{CH}	175°C
Storage Temperature	T _{STG}	-65°C to +175°C

SO-8 Power Package Physical Dimensions

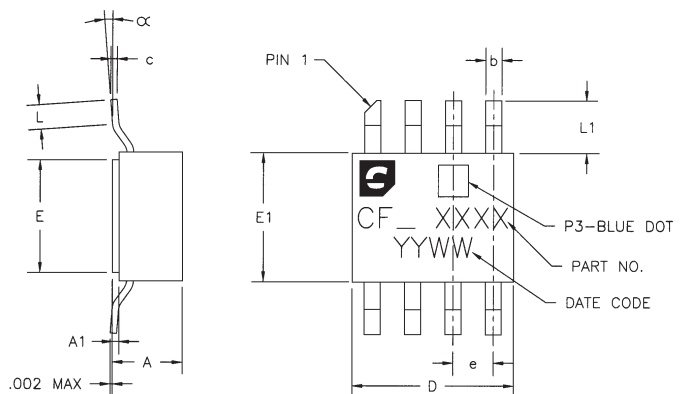

DIMENSION	MINIMUM	NOMINAL	MAXIMUM
A		.086[2.184]	.100[2.540]
A1	.005[.1270]	.008[.2032]	.011[.2794]
b	.017[.4318]	.020[.5080]	.023[.5842]
c	.007[.1778]	.008[.2032]	.009[.2286]
D	.195[4.953]	.200[5.080]	.205[5.207]
E	.135[3.429]	.140[3.556]	.145[3.683]
E1	.155[3.937]	.160[4.064]	.165[4.191]
e		.050[1.270]	
L	.020[.5080]		.040[1.016]
L1	.055[1.397]	.065[1.651]	.075[1.905]
α	0°		8°

DIMENSIONS IN INCHES [MILLIMETERS]

Notes:

1. Sum to two tones with 1 MHz spacing = 25 dBm.
2. See thermal considerations information on page 4.
3. Maximum potential difference across the device (V_d + V_g) cannot exceed 12V.

Typical Scattering Parameters (TA = 25°C, Vds = 5 V, Ids = 600 mA)

Frequency (GHz)	S ₁		1		S ₂		1		S ₁		2	
	Mag	Ang	Mag	Ang	Mag	Ang	Mag	Ang	Mag	Ang	Mag	Ang
0.6	0.927	-129.75	8.7	102.7	0.024	21.95	0.576	-178.45				
1.0	0.914	-154.69	5.449	84.82	0.025	8.72	0.6	175.04				
1.3	0.908	-162.37	4.423	76.85	0.027	4.79	0.588	172.66				
1.4	0.904	-164.19	4.225	74.15	0.028	2.63	0.578	171.66				
1.5	0.9	-166.3	4.066	71.35	0.029	2.62	0.567	170.4				
1.6	0.897	-168.59	3.947	68.38	0.03	-0.23	0.555	168.55				
1.7	0.893	-171.31	3.847	65.08	0.032	-1.99	0.542	166.26				
1.8	0.889	-174.42	3.768	61.32	0.033	-5.24	0.53	163.11				
1.9	0.866	-178.39	3.693	57.12	0.035	-8.52	0.52	159.17				
2.0	0.883	177.09	3.605	52.62	0.05	-10.6	0.512	154.61				
2.1	0.78	171.92	3.504	48.01	0.035	-14.75	0.508	149.35				
2.2	0.879	166.48	3.386	42.82	0.036	-18.18	0.509	143.77				
3.0	0.917	135.01	2.081	13.19	0.03	-41.27	0.623	118.42				
3.5	0.932	137.14	1.635	8.18	0.028	-41.69	0.643	124.18				
4.0	0.913	143.42	1.641	3.36	0.032	-41.15	0.557	131.38				

(TA = 25°C, Vds = 8 V, Ids = 400 mA)

0.6	0.91	-131.25	9.129	100.5	0.026	17.07	0.521	-174.04				
1.0	0.904	-155.33	5.68	82.61	0.027	6.34	0.548	178.8				
1.3	0.899	-167.2	4.574	74.6	0.028	0.5	0.538	176.86				
1.4	0.897	-164.68	4.366	71.76	0.029	1.6	0.53	176.13				
1.5	0.892	-166.63	4.203	68.96	0.03	-0.36	0.519	174.97				
1.6	0.891	-168.82	4.063	65.99	0.031	-3.35	0.507	173.4				
1.7	0.886	-171.54	3.951	62.5	0.032	-4.87	0.496	171.26				
1.8	0.883	-174.77	3.86	58.87	0.034	-7.72	0.483	168.5				
1.9	0.88	-178.6	3.783	54.83	0.034	-9.68	0.472	164.9				
2.0	0.877	176.74	3.696	50.36	0.035	-13.77	0.463	160.21				
2.1	0.873	171.86	3.589	45.5	0.036	-16.17	0.458	154.9				
2.2	0.874	166.29	3.46	40.56	0.037	-21.9	0.458	149.35				
3.0	0.915	135.06	2.136	10.26	0.031	-46.6	0.579	121.99				
3.5	0.93	137.37	1.662	4.59	0.027	-43.86	0.611	128.44				
4.0	0.912	143.75	1.642	-0.35	0.031	-43.95	0.541	137.64				

RF Match Data shown in the performance graphs was taken in the test circuit shown at right. Layout is important for proper operation. Phase length of input and output 50Ω line varies as a function of exact desired frequency of operation. Output shunt inductor effects output performance. Celeritek recommends the use of a high impedance printed inductor Lambda/4 in length. Please contact the factory for an evaluation board and/or more detailed application support.

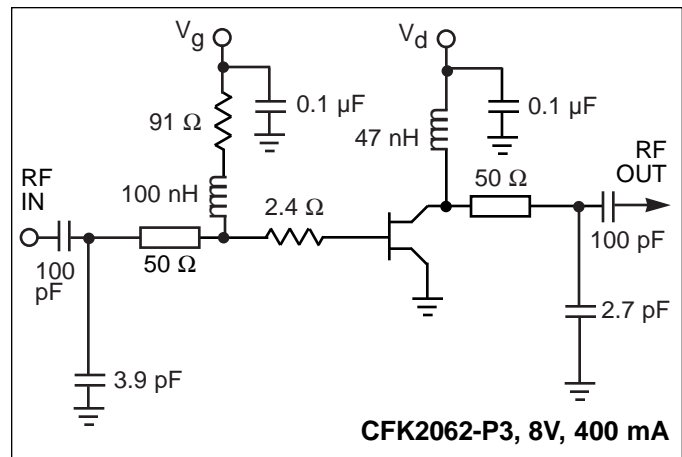



Typical Performance

Power Output & Power Added Efficiency vs Power Input
1.95 GHz, $V_{DS} = 8\text{ V}$, $I_{DS} = 400\text{ mA}$

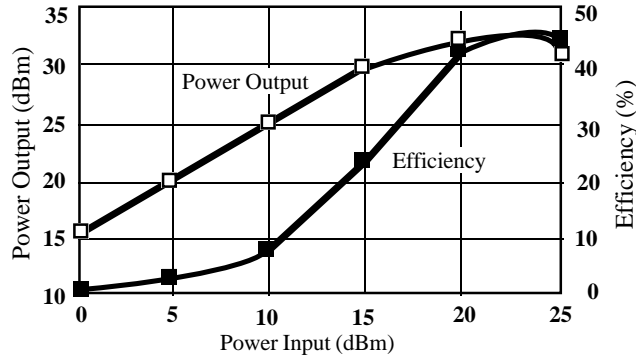

Power Output & Power Added Efficiency vs Power Input
1.95 GHz, $V_{DS} = 5\text{ V}$, $I_{DS} = 600\text{ mA}$

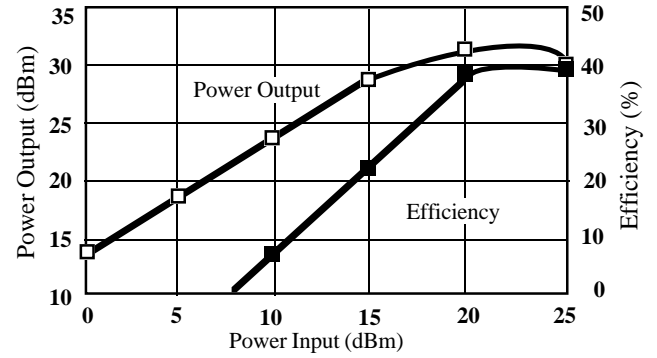

Power Output and Gain vs Frequency
 $V_{DS} = 8\text{ V}$, $I_{DS} = 400\text{ mA}$

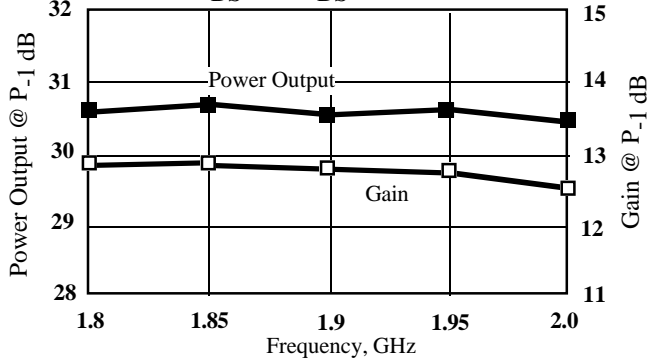

Power Output and Gain vs Frequency
 $V_{DS} = 5\text{ V}$, $I_{DS} = 600\text{ mA}$

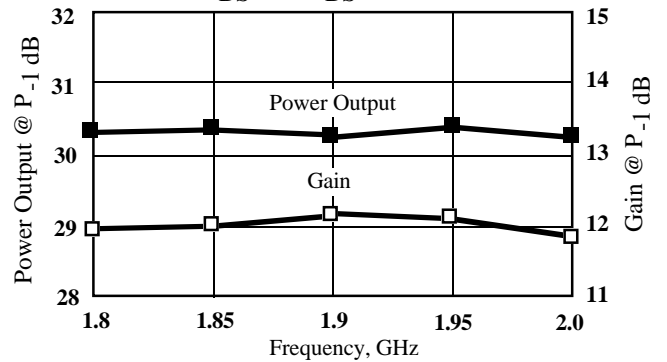

Power Output and Gain vs Voltage @ 1.95 GHz
 $I_{DS} = 400\text{ mA}$

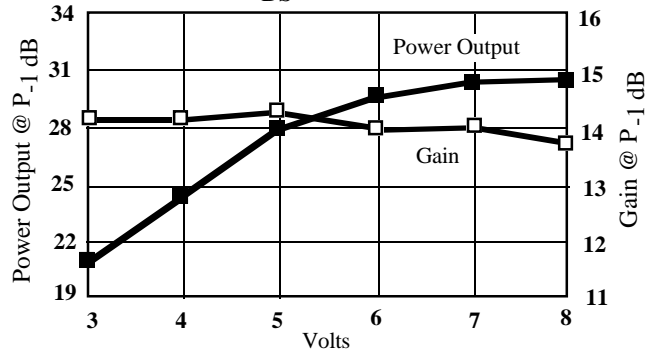

Power Output and Gain vs Voltage @ 1.95 GHz
 $I_{DS} = 600\text{ mA}$

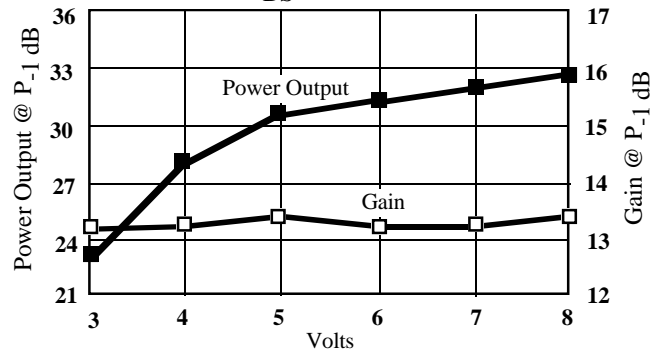

Thermal Considerations

The data shown was taken on a 31 mil thick FR-4 board with 1 ounce copper on both sides. The board was mounted to a baseplate with 3 screws as shown. The screws bring the top side copper temperature to the same value as the baseplate. The thermal resistance to the indicated reference lead, Θ_{JL} , is 12°C/W. The thermal resistance to the reference screw is 14°C/W.

1. Use 1 or 2 ounce copper if possible.
2. Solder all eight leads of the CFK2062-P3 package to the appropriate electrical connection.
3. Solder the copper pad on the backside of the CFK2062-P3 package to the ground plane.
4. Use a large ground pad area with many plated through-holes as shown.
5. If possible, use at least one screw no more than 0.2 inches from the CFK2062-P3 package to provide a low thermal resistance path to the baseplate of the package.

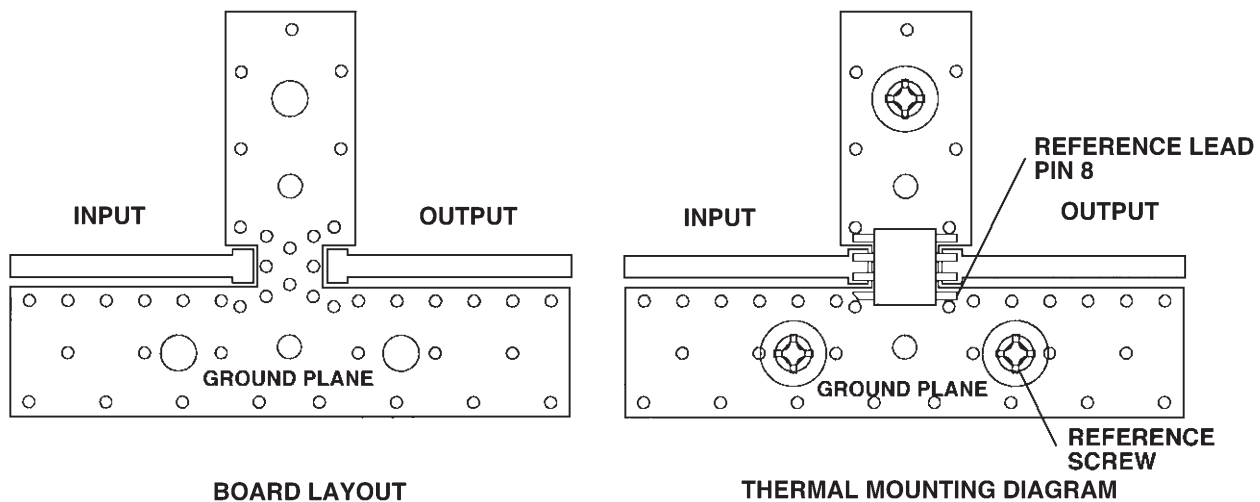

Ordering Information

The CFK2062-P3 power stage is available in a SO-8 surface mount package. Devices are available in tape and reel. Ordering part numbers are listed.

<u>Part Number for Ordering</u>	<u>Function</u>	<u>Package</u>
CFK2062-P3	1.8 - 2.0 GHz Power Stage	SO-8 surface mount power package
CFK2062-P3-000T	1.8 - 2.0 GHz Power Stage	SO-8 surface mount power package in tape and reel

Celeritek reserves the right to make changes without further notice to any products herein. Celeritek makes no warranty, representation or guarantee regarding the suitability of its products for any particular purpose, nor does Celeritek assume any liability arising out of the application or use of any product or circuit, and specifically disclaims any and all liability, including without limitation consequential or incidental damages. "Typical" parameters can and do vary in different applications. All operating parameters, including "Typicals" must be validated for each customer application by customer's technical experts. Celeritek does not convey any license under its patent rights nor the rights of others. Celeritek products are not designed, intended, or authorized for use as components in systems intended for surgical implant into the body, or other applications intended to support or sustain life, or for any other application in which the failure of the Celeritek product could create a situation where personal injury or death may occur. Should Buyer purchase or use Celeritek products for any such unintended or unauthorized application, Buyer shall indemnify and hold Celeritek and its officers, employees, subsidiaries, affiliates, and distributors harmless against all claims, costs, damages, and expenses, and reasonable attorney fees arising out of, directly or indirectly, any claim of personal injury or death associated with such unintended or unauthorized use, even if such claim alleges that Celeritek was negligent regarding the design or manufacture of the part. Celeritek is a registered trademark of Celeritek, Inc. Celeritek, Inc. is an Equal Opportunity/Affirmative Action Employer.