

# MX-COM, INC. MiXed Signal ICs

DATA BULLETIN

## CMX017 UHF FM/FSK Transmitter

ADVANCE INFORMATION

### Features

- Direct FM/FSK UHF Modulator
- Adjustable Modulator Output Power
- Integrated Power Amplifier with Output Power up to +20dBm (100mW)
- Low Power 2.7V Operation
- Powersave and Zero-Power (<math><10\mu\text{A}</math>) Modes
- 28-Pin SSOP Package

### Applications

- General Radio Link 860-965MHz
- General 915MHz ISM Band (USA)
- Spread Spectrum Wireless Systems
- Fixed Frequency Transmissions
- Analog/Digital Cordless Phones
- Handheld Data Terminals
- SO-HO Wireless Data Links

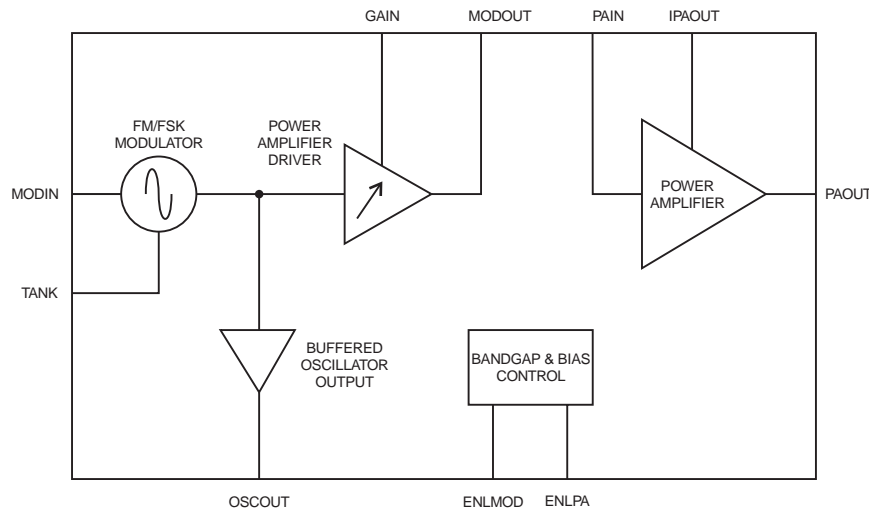

The CMX017 is a single chip UHF FM/FSK transmitter that combines both the RF VCO Modulator and RF Power Amplifier. It is suitable for both audio FM and digital FSK transmissions.

A buffered oscillator output provides the RF signal drive to an external synthesizer or fixed frequency phase-locked loop for channel frequency selection. Modulator output power is adjustable over a 20dB range and the integrated power amplifier delivers up to +20dBm. The device also includes a powersave mode: "Transmit Standby" and a zero-power mode: "Sleep". These allow independent power down control of both the modulator and power amplifier, thereby maximizing battery life. The device can be used in conjunction with the CMX018, a double-conversion super-heterodyne receiver, to implement a complete UHF radio link.

The CMX017 operates from a 2.7V to 3.3V power supply and is available in the following package style: 28-pin SSOP (CMX017D6).

# CONTENTS

Section	Page
<b>1 Block Diagram</b> .....	<b>3</b>
<b>2 Signal List</b> .....	<b>4</b>
<b>3 External Components</b> .....	<b>5</b>
<b>4 General Description</b> .....	<b>6</b>
4.1 FM/FSK Modulator + PA Driver .....	6
4.2 Power Amplifier (PA) .....	6
4.3 Power-Down Modes .....	6
<b>5 Application Notes</b> .....	<b>6</b>
5.1 Generation of the Modulated RF Signal .....	6
5.2 Power-Down Modes .....	7
<b>6 Performance Specification</b> .....	<b>10</b>
6.1 Electrical Performance .....	10
6.1.1 Absolute Maximum Ratings.....	10
6.1.2 Operating Limits .....	10
6.1.3 Operating Characteristics.....	10
6.1.4 Packaging.....	12

MX-COM, Inc reserves the right to change specifications at any time and without notice.
---

# 1 Block Diagram

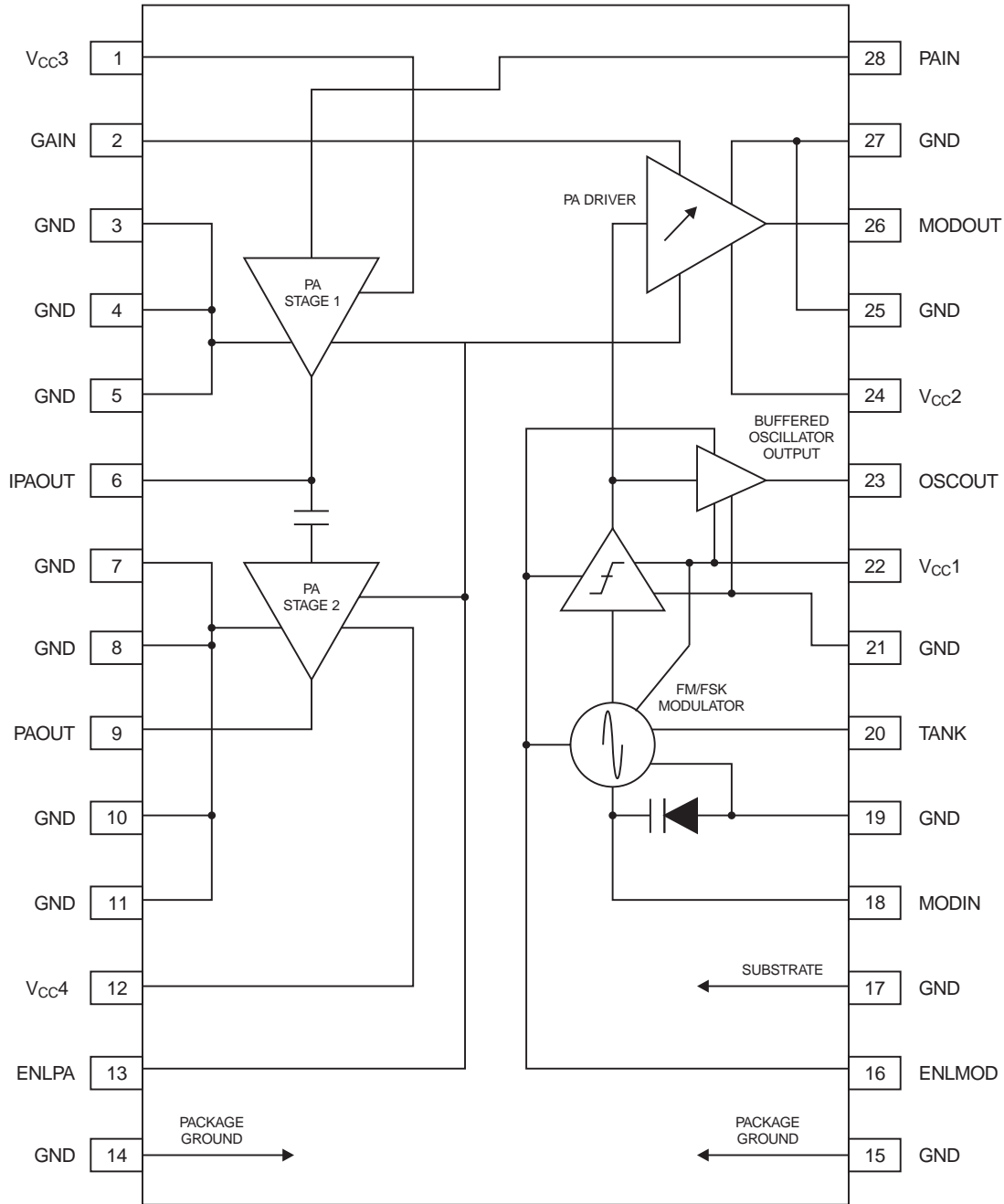

Figure 1: Internal Block Diagram

## 2 Signal List

Pin No.	Signal		Description
	D6 Package Name	Type	
1	V <sub>CC3</sub>	power	Power amplifier (first stage) power supply - nominally 3.0V
2	GAIN	input	Modulator output (pin 26) - Power control
3	GND	ground	Ground-plane connection to the power amplifier
4	GND	ground	Ground-plane connection to the power amplifier
5	GND	ground	Ground-plane connection to the power amplifier
6	IPAOUT	output	Output (open-collector) from the first stage of the power amplifier
7	GND	ground	Ground-plane connection to the power amplifier
8	GND	ground	Ground-plane connection to the power amplifier
9	PAOUT	output	Output (open-collector) from the second stage of the power amplifier
10	GND	ground	Ground-plane connection to the power amplifier
11	GND	ground	Ground-plane connection to the power amplifier
12	V <sub>CC4</sub>	power	Power amplifier (second stage) power supply – nominally 3.0V
13	ENLPA	CMOS input	Power Amplifier powersave logic control. A logic “0” powers down the Power Amplifier and Driver stages
14	GND	ground	Ground-plane connection
15	GND	ground	Ground-plane connection
16	ENLMOD	CMOS input	Modulator zero-power logic control. A logic “0” powers down the Modulator and Buffered Oscillator stages
17	GND	ground	Ground-plane connection
18	MODIN	input	Baseband modulation input signal
19	GND	ground	Ground-plane connection to the VCO
20	TANK	input	VCO Tank circuit/Resonator connection
21	GND	ground	Ground-plane connection to the modulator and VCO buffer
22	V <sub>CC1</sub>	power	Modulator power supply – nominally 3.0V
23	OSCOOUT	output	Buffered Oscillator (open-collector) output
24	V <sub>CC2</sub>	power	Power Amplifier Driver power supply - nominally 3.0V
25	GND	ground	Ground-plane connection for the Power Amplifier Driver
26	MODOUT	output	Modulator output
27	GND	ground	Ground-plane connection for the Power Amplifier Driver
28	PAIN	input	Power Amplifier input

**Table 1: Signal List**

### 3 External Components

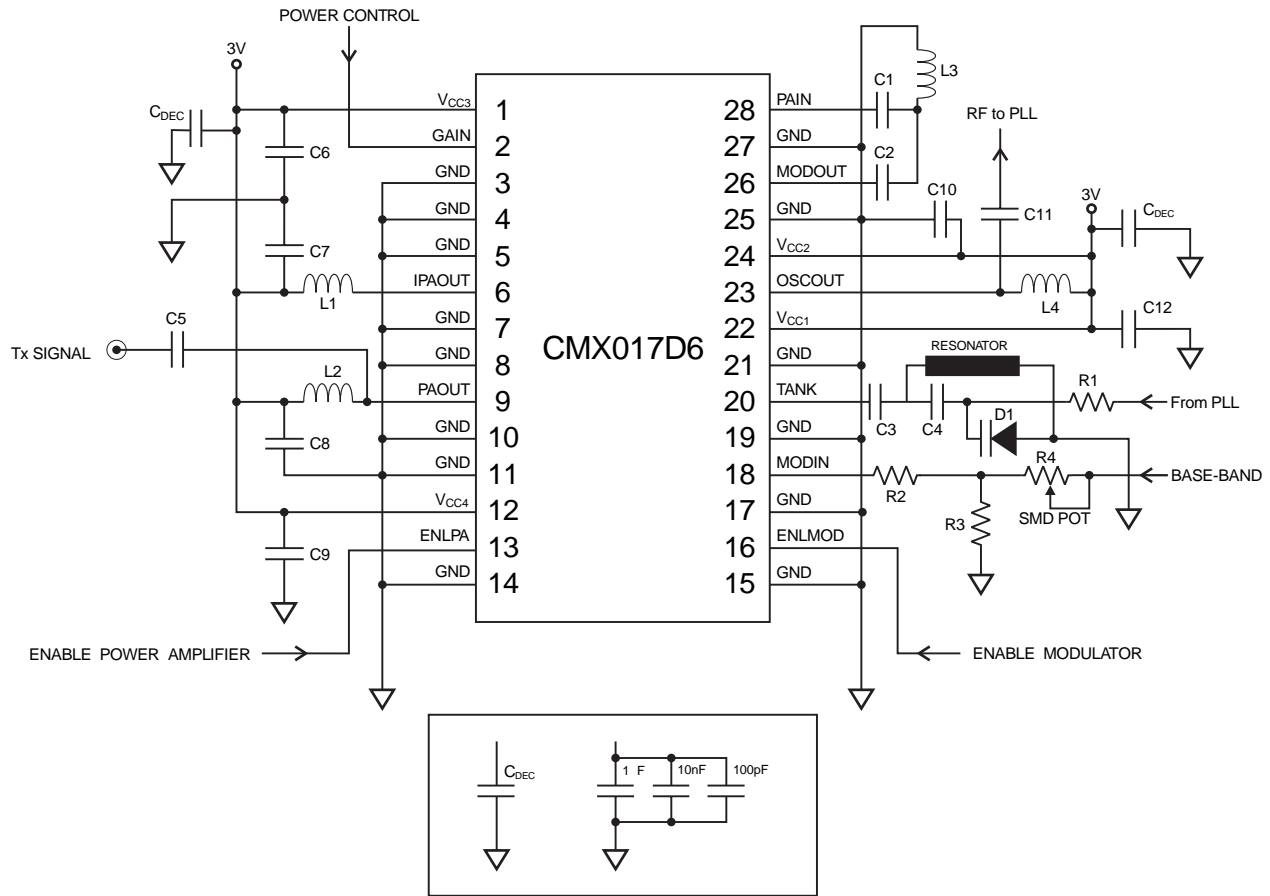

Figure 2: Example of CMX017 with External Components

C1	5.6pF
C2	33pF
C3	4.3pF
C4	TBD
C5	100pF
C6	100pF
C7	100pF
C8	100pF
C9	100pF
C10	100pF
C11	100pF

C12	100pF	
D1	Varactor	Varactor diode, type SMV1233-011
~	Resonator	Co-Axial Resonator, type RG402, length = 11mm, shorted end
L1	1.5nH	
L2	22nH	
L3	6.8nH	
L4	22nH	
R1	10kΩ	
R2	10kΩ	
R3	TBD	Value is application dependent
R4	TBD	SMD potentiometer - value is application dependent

Note: Components are surface mount, type SMD0603, unless otherwise indicated.

Figure 3: Example of CMX017 with External Components for 915MHz Operation

## 4 General Description

The CMX017 is a single chip UHF FM/FSK transmitter that combines both the RF VCO Modulator and RF Power Amplifier. It is suitable for both audio FM and digital FSK transmissions.

A buffered oscillator output provides the RF signal drive to an external synthesizer or fixed frequency phase-locked loop for channel frequency selection. Modulator output power is adjustable over a 20dB range and the integrated power amplifier delivers up to +20dBm. The device also includes a powersave mode: "Transmit Standby" and a zero-power mode: "Sleep". These allow independent power down control of both the modulator and power amplifier, thereby maximizing battery life. The device can be used in conjunction with the CMX018 a double-conversion super-heterodyne receiver, to implement a complete UHF radio link.

### 4.1 FM/FSK Modulator + PA Driver

The modulator circuit uses an integrated oscillator whose frequency can be directly modulated by the DC-coupled input base-band signal, at the MODIN pin, to generate a frequency modulated (FM or FSK) RF signal. The oscillator requires an external varactor and resonator circuit, connected at the TANK pin, to tune to the required RF channel. A buffered oscillator signal is provided from an open-collector output, at the OSCOUT pin, to drive an external frequency synthesizer for the channel selection.

The output power, at the MODOUT pin, is variable over a 20dB range. The output power is maximum when the GAIN pin is connected to  $V_{CC}$  and is reduced by typically 20dB when this pin is connected to 0V. The output impedance at the MODOUT pin is typically 50 $\Omega$ .

### 4.2 Power Amplifier (PA)

The power amplifier has two internal stages, each biased for class-B operation, and is designed to have a fixed overall power gain. The input and output impedances can be terminated with 50 $\Omega$ . A typical power gain improvement of 2dB is achieved using simple external matching networks.

### 4.3 Powersave and Zero-Power Modes

The Modulator and Buffered Oscillator stages are powered down independently of the PA Driver + Power Amplifier stages by means of the ENLMOD and ENLPA logic inputs:

A logic '0' at ENLMOD powers down the Modulator and Buffered Oscillator stages.

A logic '0' at ENLPA powers down the PA Driver and Power Amplifier stages.

Refer to the block diagram in Figure 1 and to Section 5.

## 5 Application Notes

### 5.1 Generation of the Modulated RF Signal

The modulator on the CMX017 relies on the direct modulation of the RF Voltage Controlled Oscillator (VCO), which is stabilized to the channel center frequency by an external Frequency Synthesizer or Phase Locked Loop (PLL). The user has control over the external PLL filter and VCO tank components and choice of these components will have an impact upon the following PLL parameters:-

- Closed loop bandwidth, settling time and transient response
- Modulation linearity
- VCO phase noise

Three modulation requirements may be achieved as follows:

#### 5.1.1 The minimum modulation signal frequency is above the PLL Closed Loop Bandwidth

In applications where the transmit channel frequency is fixed or occasionally changed, a narrow PLL bandwidth can be chosen such that the minimum modulation frequency is in excess of the PLL bandwidth. With the PLL active whilst the base-band signal is applied to the modulator there will be negligible distortion of the modulated RF output signal. A benefit of this technique is that an output phase noise improvement is achieved, compared to the free running VCO phase noise characteristic.

#### 5.1.2 The minimum modulation signal frequency is within the PLL Closed Loop Bandwidth

In Frequency Hopped Spread Spectrum applications the frequency synthesizer must be agile. Consequently the PLL bandwidth should be designed to achieve the required hop-rate and, in most systems this bandwidth will exceed the minimum modulation frequency. With the PLL active during modulation, the loop will

compensate for the signal frequency components within the loop bandwidth, introducing a frequency dependant distortion of the modulated RF output signal.

To avoid the modulation distortion the carrier frequency is tuned by the external synthesizer chip, with no modulating signal applied. The synthesizer control is then disabled, by setting the charge-pump output of the synthesizer to tri-state. The DC coupled base-band signal, applied to the MODIN pin, then modulates the free running VCO to generate the FM or FSK output signal.

### 5.1.3 A flat modulator response is required down to DC, whilst benefiting from the phase noise improvements due to the PLL (Two-Point Modulation).

Unlike in the above two cases, where a fixed reference frequency is used in the PLL, the Two-Point Modulation technique requires modulation inputs to both the PLL reference oscillator and to the RF VCO circuits.

The modulation signal should be applied to both modulation inputs with suitable AC/DC levels and with the correct phase to achieve cancellation of the loop's feedback. This prevents the radio's PLL circuitry from counteracting the modulation process and so provides a clean flat modulation response down to DC.

## 5.2 Powersave and Zero-Power Modes

It is possible to power down each section of the transmitter independently. This feature may be useful when the CMX017 is configured, with the CMX018, as a radio transceiver. It allows the transmitter to be powered on and off, thereby saving power, during the sleep and standby periods.

In **SLEEP** mode (ENLMOD='0' and ENLPA='0') all sections of the device are powered down and the current consumption is reduced to less than 10 $\mu$ A. This is the zero-power mode.

In **TRANSMIT-STANDBY** mode (ENLMOD='1' and ENLPA='0') only the PA Driver and Power Amplifier stages are powered down, while the Modulator and Buffered Oscillator remain active. This powersave mode allows the external frequency synthesizer to stabilize the channel center frequency prior to the RF transmission.

In **TRANSMIT** mode (ENLMOD='1' and ENLPA='1') both the Modulator and the Power Amplifier sections of the device are fully operational.

**Note:** The device can be used as a stand alone "UHF Power Amplifier" by forcing (ENLMOD='0' and ENLPA='1'). The efficiency is maximized by connecting the V<sub>CC2</sub> pin to 0V. (The V<sub>CC1</sub> pin must remain connected to 3.0V.)

## 5.3 Lower Output Power Applications

For very short range applications the antenna drive can be taken from the modulator output, MODOUT, at pin 26. The Power Amplifier is powered down by connecting V<sub>CC3</sub> and V<sub>CC4</sub> (pins 1 and 12) to 0V. This allows the supply current to be minimized and the Modulator output to be enabled or disabled using the ENLPA input at pin 13.

## 5.4 Example Schematic and Layout

The following schematic (Figure 4) and printed circuit layout (Figure 5 and Figure 6) present a typical application interface for the CMX017. To aid legibility, the schematic and layout are available electronically from the MX-COM website <http://www.mxcom.com>.

Alternative components and component values are shown on the schematic. These should be selected according to the intended application. The schematic uses the following ICs:

U2	IC Works	WB1315X
U4	Analog Devices	AD8532-SO8





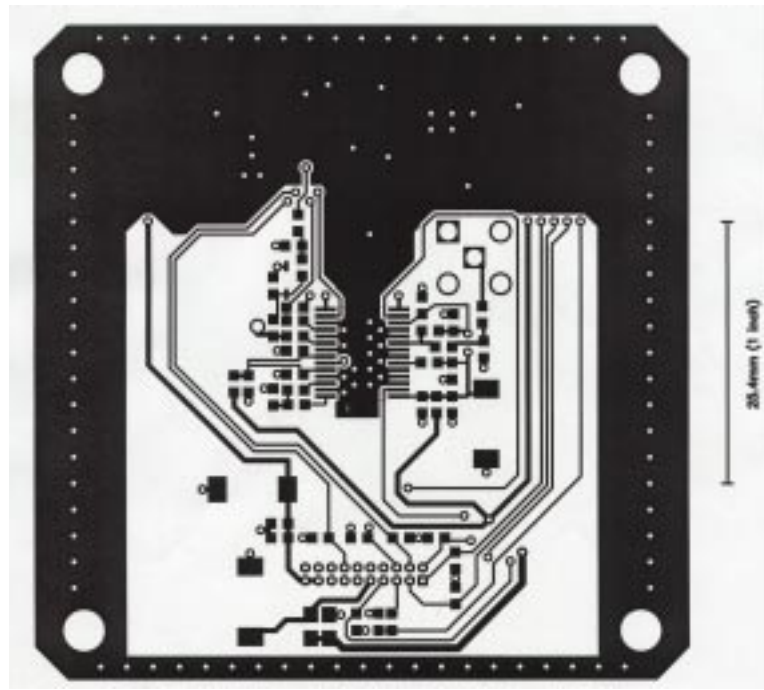

Figure 5: Application Layout - Top Copper

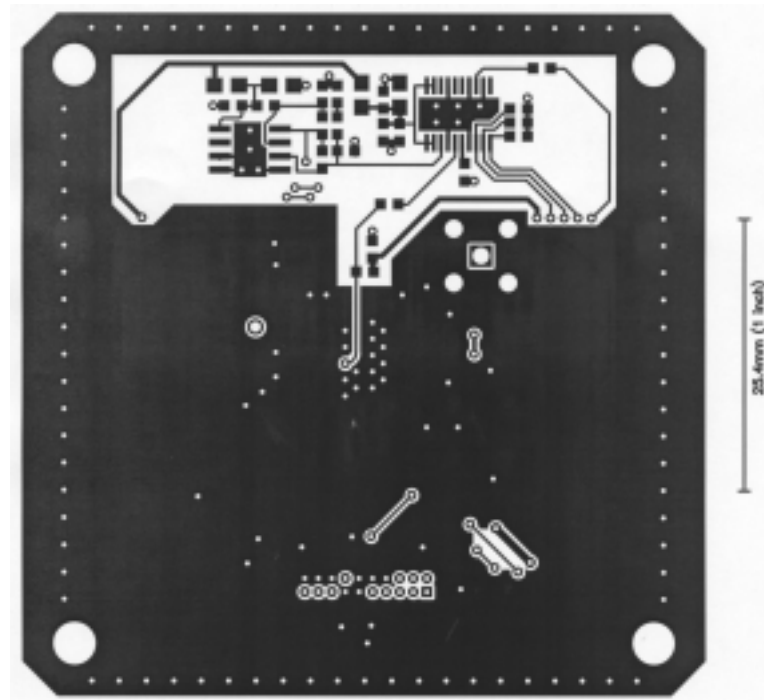

Figure 6: Application Layout - Bottom Copper (not reversed)

Available from <http://www.mxcom.com>.

## 6 Performance Specification

### 6.1 Electrical Performance

#### 6.1.1 Absolute Maximum Ratings

Exceeding these maximum ratings can result in damage to the device.

	Pin	Min.	Max.	Units
Supply ( $V_{CC}$ )	1, 12, 22, 24	-0.3	7.0	V
Input Voltage	2, 13, 16, 18, 20	-0.3	$V_{CC} + 0.3$	V
Power Amplifier Input Power	28		+7	dBm
<b>D6 Package</b>				
Total Allowable Power Dissipation at $T_{AMB} = 25^{\circ}\text{C}$			1100	mW
Derating above $25^{\circ}\text{C}$			11	mW/ $^{\circ}\text{C}$ above $25^{\circ}\text{C}$
Storage Temperature		-55	+125	$^{\circ}\text{C}$

**Table 2: Absolute Maximum Ratings**

#### 6.1.2 Operating Limits

Correct operation of the device outside these limits is not implied.

	Notes	Min.	Max.	Units
Supply ( $V_{CC}$ )		2.7	3.3	V
Operating Frequency Range		860	965	MHz
Operating Temperature		-10	+60	$^{\circ}\text{C}$

**Table 3: Operating Limits**

#### 6.1.3 Operating Characteristics

For the following conditions unless otherwise specified:

$V_{CC} = 2.7\text{V}$  to  $3.3\text{V}$ ,  $T_{AMB} = -10^{\circ}\text{C}$  to  $+60^{\circ}\text{C}$ ,  
 $\text{RF} = 915\text{MHz}$ ,  $50\Omega$  source and load impedance.

	Pin	Note	Min.	Typ.	Max.	Units
<b>DC Parameters</b>						
Device Fully Enabled (ENLPA=HI and ENLMOD=HI)						
$I_{CC}$ [Output Power = +20dBm at PAOUT (pin 9)]		1	-	130	-	mA
$I_{CC}$ [Output Power = +10dBm at PAOUT (pin 9)]		1	-	60	-	mA
$I_{CC}$ [Output Power = +0dBm at PAOUT (pin 9)]		1	-	40	-	mA
Device in Power-Down Modes						
$I_{CC}$ in <b>STANDBY</b> mode (ENLPA=LO and ENLMOD=HI)		1	-	24	-	mA
$I_{CC}$ in <b>SLEEP</b> Mode (ENLPA=LO and ENLMOD=LO)		1	-	TBD	10	$\mu\text{A}$

	Pin	Note	Min.	Typ.	Max.	Units
<b>AC Parameters</b>						
Modulator, VCO Buffer and PA Driver						
Output Power [GAIN (pin 2) at V <sub>CC</sub> ]	26		-	-4.0	-	dBm
Output Power [GAIN (pin 2) at 1.5V]	26		-	-9.0	-	dBm
Output Power [GAIN (pin 2) at 1.0V]	26		-	-14	-	dBm
Buffered VCO Output at OSCOUT pin	19	2	-	-10	-	dBm
Oscillator Second Harmonic Output	26	3	-	-25	-	dBc
Oscillator Third Harmonic Output	26	3	-	-35	-	dBc
Modulation Sensitivity	18	4	-	0.4	-	MHz/V
Maximum Deviation	26	5	-	1.5	-	MHz
Input Data Rate	18		-	-	TBD	kBits/S
Output VSWR (at maximum output power)	26		-	TBD	-	
Power Amplifier						
Power Gain	28, 9		-	22	-	dB
Power Gain (with external matching at V <sub>CC</sub> = 3.3V)	28, 9		-	24	-	dB
Maximum Power Gain Variation	28, 9	6	-	2.0	-	dB
Maximum Power Gain Variation (with matching)	28,9	6	-	1.5	-	dB
Input 1dB Compression Point	9		-	+1.0	-	dBm
Input 1dB Compression Point (with matching)	9		-	0	-	dBm
Reverse Isolation	9, 28		-	-35	-	dB
Output VSWR (at maximum output power)	9		-	TBD	-	dB

**Notes:**

1. Total current from the external 3V power supply.
2. Power measured into a 50Ω load.
3. With external matching.
4. Stepped modulation voltage input from 1.0V to 2.0V.
5. Stepped modulation voltage from 0V to 3.0V.
6. Input Power = -15dBm to -1dBm.

## 6.2 Packaging

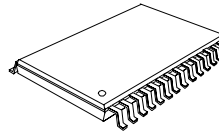
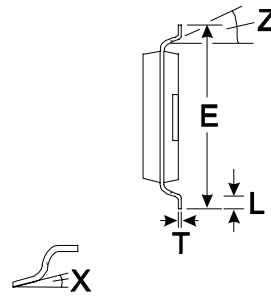
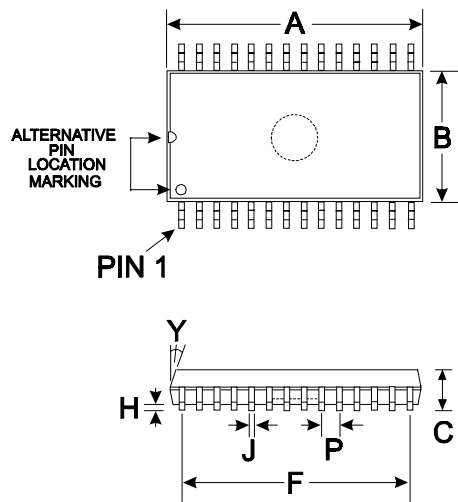

DIM.	MIN.	TYP.	MAX.
* A	0.396 (10.06)		0.407 (10.34)
* B	0.205 (5.21)		0.213 (5.39)
C	0.086 (1.67)		0.079 (2.00)
E	0.301 (7.65)		0.312 (7.90)
F		0.333 (8.45)	
H	0.002 (0.05)		0.008 (0.21)
J	0.010 (0.25)		0.015 (0.38)
L	0.022 (0.56)		0.037 (0.94)
P		0.026 (0.65)	
T	0.005 (0.13)		0.009 (0.23)
X	0°		8°
Y	7°		9°
Z	4°		10°

NOTE :

- \* A & B are reference datum's and do not include mold deflash or protrusions.

All dimensions in inches (mm.)  
Angles are in degrees

Figure 7: 28-Pin Plastic SSOP Mechanical Outline: *Order as part no. CMX017D6*

## 6.3 Handling Precautions

As this device is a high performance RF integrated circuit and is ESD sensitive. Adequate precautions must be taken during handling and assembly of this device.