

RoHS Compliant

COAXIAL CONNECTORS

2008

CAT.NO.COAX-007A-E.FEB.2008

COAXIAL
CONNECTORS

- FREQUENCY RANGE TO 3GHz
- PUSH-ON COUPLING

CN50 Series

CN50 series connectors are small sized coaxial connectors for board to cable application, conforming to IEC60169-10 (Type SMB) . Low cost with punched parts. For high frequency signal transmission and high density packaging in the device.

Most suitable for mobile phone stations and radio communications equipment at access points.

Applicable frequencies : from DC up to 3GHz. High performance with a VSWR (voltage standing wave ratio) of 1.2 or less.

- Push-on coupling, compact and lightweight.
- Crimp cable termination with limited variation in high frequency.
- Low profile 9.5 mm high when mated.
- A high degree of reliability provides stable electric continuity and high frequency performance.
- Applications : Base Station for Mobile Communications, Radio LAN Access Point, Radio Communication Equipment, Broadcasting Equipment, Measuring Instruments



SPECIFICATIONS

Characteristic Impedance	50Ω
Frequency Range	DC to 3GHz
D. W. Voltage	AC500Vr.m.s. (1minute)
Insulation Resistance	500megohms min. (DC500V)
Contact Resistance	Center Contacts : 15milliohms max. Outer Contacts : 8milliohms max.
V. S. W. R.	1.2 max. (DC to 3GHz)
Applicable Cables	1.5D-V

MATERIALS/FINISHES

Description	Materials/Finishes
Center Contacts	Copper Alloy/Gold Plated over Nickel
Outer Contacts	Copper Alloy/Nickel Plated
Insulator	Synthetic Resin
Sleeve	Copper Alloy/Nickel Plated
Ferrule	Copper Alloy/Nickel Plated

Types and Combinations

Receptacle

P/N : CN50R01D00



Cable Harness



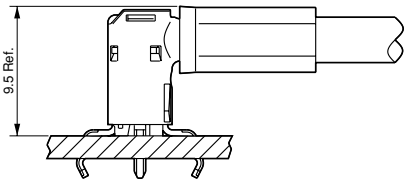

9.5 Ref.

Dimensions in millimeters

For the cable application type, harnessed connectors which satisfy your specification are supplied. We can also provide connectors and cables other than those listed in this catalog. For detail, please consult us.

CN50 Series

RECEPTACLE

PLUG

Dimensions in millimeters

RECEPTACLE

Through-hole Solder · Straight
Part Number : CN50R01D00

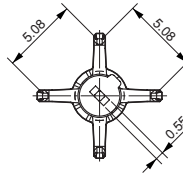
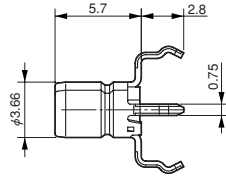

PC BOARD LAYOUT · MOUNTING SIDE (REF.)
(PC BOARD THICKNESS : 1.6mm)

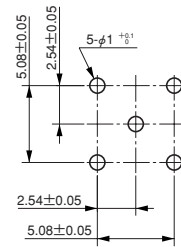

PLUG

Right-angle · Cable Assembly



For Cable application type, harnessed connectors which satisfy your specification are supplied. For details please consult us.

Applicable Cables : 1.5D-2V Equivalent

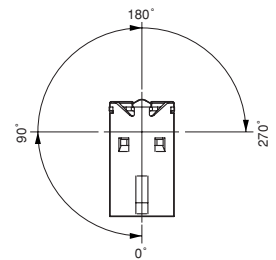
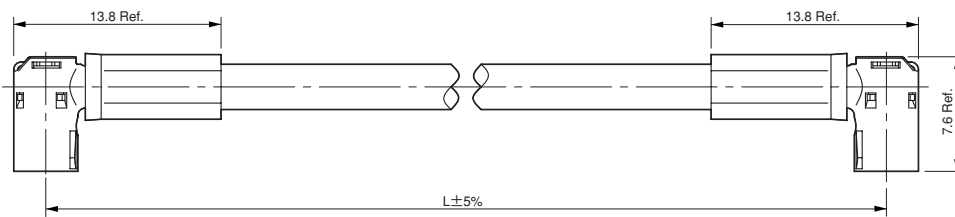

Before placing an order

- ①The values specified in this catalogue are only for reference. The products and specifications are subject to change without notice. Contact our sales staff for further information before considering or ordering any of our products.
For purchase, a product specification must be agreed upon.
- ②Users are requested to provide protection circuits and redundancy circuits to ensure safety of the equipment, and sufficiently review the suitability of JAE's products to the equipment.
- ③The products presented in this catalogue are designed for the uses recommended below.
We strongly suggest you contact our sales staff when considering use of any of the products in any other way than the recommended applications or for a specific use that requires an extremely high reliability.

(1)Applications that require consultation:

- (i)Please contact us if you are considering use involving a quality assurance program that you specify or that is peculiar to the industry, such as:
Automotive electrical components, train control, telecommunications devices (mainline), traffic light control, electric power, combustion control, fire prevention or security systems, disaster prevention equipment, etc.
- (ii)We may separately give you our support with a quality assurance program that you specify, when you think of a use such as:
Aviation or space equipment, submarine repeaters, nuclear power control systems, medical equipment for life support, etc.

(2)Recommended applications include:

Computers, office appliances, telecommunications devices (terminals, mobile units), measuring equipment, audiovisual equipment, home electric appliances, factory automation equipment, etc.

Japan Aviation Electronics Industry, Limited

1-19, Aobadai 3-chome, Meguro-ku, Tokyo 153-8539, Japan
Telephone: (81)3-3780-2768 Facsimile: (81)3-3780-2883

<http://www.jae.com>

<http://www.jae-connector.com>

JAE Electronics, Inc.

142 Technology Drive, Suite 100 Irvine, California 92618-2430, U.S.A.
Telephone: (1)949-753-2600 Facsimile: (1)949-753-2699
(800)JAE-PART (523-7278) Toll free in U.S.A. except in California and Alaska

JAE Europe, Ltd.

Coliseum Business Center, Riverside Way, Camberley, Surrey GU15 3YL, U.K.
Telephone: (44)1276-404000 Facsimile: (44)1276-404010

JAE Taiwan, Ltd. <Taipei Branch Office>

4F-1, No.88, Sec.2, Chung Hsiao E.Rd., Taipei, Taiwan, R.O.C.
Telephone: (886)2-2396-7676 Facsimile: (886)2-2392-5929

JAE Hong Kong, Ltd.

Suites 1407-11,14/F., Tower2, The Gateway, 25 Canton Road,
Tsimshatsui, Kowloon, Hong Kong
Telephone: (852)2723-7782 Facsimile: (852)2723-9028

JAE Shanghai Co., Ltd.

RM1407, Shanghai Mart 2299 Yanan Road (West) Shanghai, 200336 P.R.C.
Telephone: (86)21-6236-0322 Facsimile: (86)21-6236-1292

JAE Singapore Pte Ltd.

33 Tannery Lane, #02-01 Hoesteel Industrial Building, Singapore 347789
Telephone: (65)6748-1332 Facsimile: (65)6748-2920

JAE Korea, Inc.

1602, City Air Tower, 159-9, Samsung-dong, Gangnam-gu, Seoul, 135-973 Korea
Telephone: (82)2-551-8959 Facsimile: (82)2-551-8958

