

File No	RDPS-POTS415	
Revision	R1	
System Application	Asymmetric Digital Subscriber Line	
Product Type	POTS Splitter For ADSL CPE side	
Product Name	CPF107J	
Date	Sep. 19 th , 2002	
Issued By	Jason Hung - Design Engineer, R&D_1	
	Jason@ycl.com.tw	
Approved By	Roger Wu – Manager, R&D_1	
	Roger@ycl.com.tw	
Issued Date		



YCL Electronics Co., Ltd.

No.95, Feng Jen Road. Feng Shan City, Kaohsiung, Taiwan, R.O.C.

This controlled document is the property of YCL Electronics Co., Ltd. Any duplication reproduction or transmission by unauthorized parties without the prior written permission of YCL Electronics Co., Ltd. is prohibited.

Table of contents

<u>Item</u>	<u>Description</u>	<u>Page</u>
1	Introduction	3
2	Reference	3
3	Abbreviations	4
4	Technical requirements	4
	4.1. Schematic	4
	4.2. ZHP-r definition	5
	4.3. DC characteristic	5
	4.4. Test loops	5
	4.5. Electrical Specification	6
	4.6. Test Method	7
	4.6.1. Insertion loss	7
	4.6.2. Return loss	8
	4.6.3. Attenuation Distortion in the Voice Band	9
5	Environmental condition	9
	5.1. Resistibility to overvoltage and overcurrents	9
	5.2. Climatic condition	9
	5.2.1. Operating temperature	9
	5.2.2. Storage and transport	9
	5.2.3. Operating humidity	9
6	Reliability conditions	9
	6.1. Thermal shock	9
	6.2. Temperature humidity exposure	9
	6.3. Vibration test	9
7	Mechanical design	10
	7.1. Mechanical	10
	7.2. Connector information	10

1. Introduction:

The CPF107J is a splitter module that has been specifically designed to implement the functionality of low pass filter in POTS over ADSL application at CPE side.

Asymmetric Digital Subscriber Line (ADSL) technology is dedicated , point to point , public network access technology that allow multiple forms of data , voice , and video to be carried over twisted-pair copper wire on the local loop between a network service provider' s(NSP' S) central office and the customer site or on local loops created either intra-building or intra-campus. Best of all , ADSL delivers this high speed performance over existing copper telephone line all while allowing traditional voice service to coexist without interruption through POTS low pass filters. The POTS-splitter on the customer premises side consists of a low pass section(installed in a separated plastic box).

The CPF107J integrate low pass filter that block the high frequency energy from reaching the POTS device and provide isolation from impedance effects of the POTS device on ADSL. In addition , these filter will also attenuate any wideband impulse noise generated by the POTS device due to the interruption of loop current(e.g. pulse dialing or on hook / off hook transfer). Because the POTS splitter connects directly to the subscriber loop media , it must also provide some protection for externally induced line hits or faults which could damage any attached equipment or endanger humans interacting with the installed equipment.The circuit protection will be provided mostly by standard central office line protection means and additional protection measures built into pots splitter to protect against line overstress which could damage the splitter itself.

2. Reference:

- | | | |
|----------|-------------|---|
| Ref. 1 : | ETS 300 001 | Attachment to Public Switched Telephone Network |
| Ref. 2 : | ITU G992.1 | Specification and testing methods for a ANNEX Type 4 POTS splitter appropriate to Japan |
| Ref. 3 : | ITU K.21 | Resistibility of subscribers terminal to overvoltage and overcurrents |

3. Abbreviations:

ADSL	Asymmetric Digital Subscriber Line
CO	Central Office
CPE	Customer Premise Equipment
POTS	Plain Old Telephone Service
RT	Remote Terminal
ADSL-NT	Network termination of ADSL
ERL	Echo Return Loss
SRL	Singing Return loss for low frequency
SRL-H	Singing Return loss for high frequency

4. Technical requirements:

4.1. Schematic :

The following drawing illustrate the block diagram of this product.

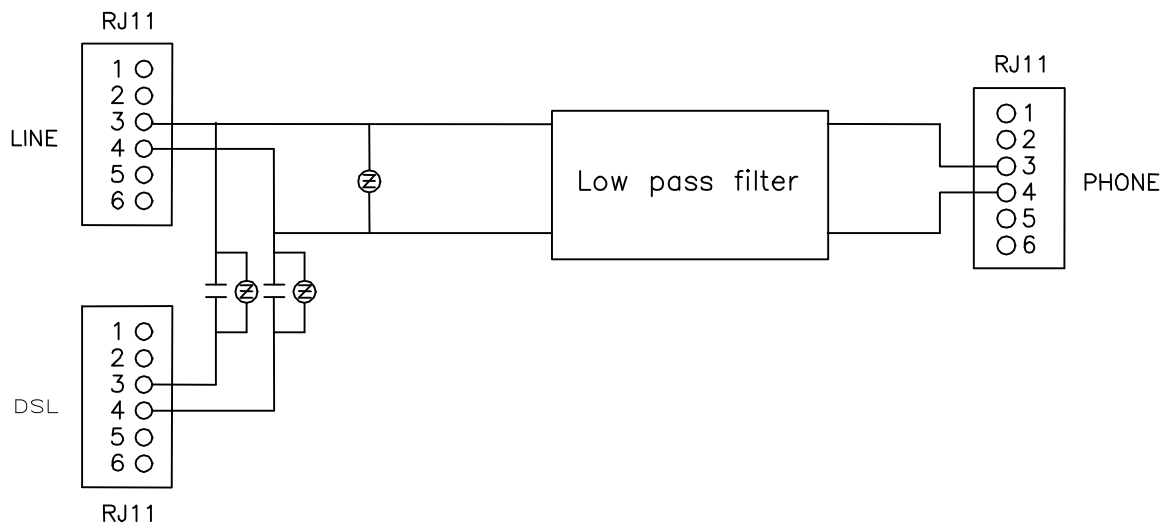

4.2. ZHP-r Definition :

ZHP-r is defined to be the impedance presented to the POTS connection by an ATU-R. The equivalent circuit of ZHP-r is showing below. The ZHP-r is valid only for voice band frequencies. The combination of capacitors in the ZHP-r is only representative.

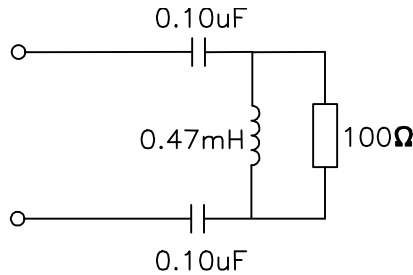

4.3. DC characteristic :

All requirement of this specification can be met in the presence of all POTS loop currents from 0mA to 130mA. This in line filter can pass POTS tip-to-ring dc voltages of 0V to 60V and ringing signals of maximum 100Vrms at any frequency from 15Hz to 30Hz with a dc component in the range from 0V to 60V. The dc resistance from tip-to-ring at the line port interface with the phone interface shorted, shall be less than or equal to 40 ohms for one splitter.

The DC resistance from tip-to-ground and from ring-to-ground at the POTS interface with the U-R interface open shall be greater than or equal to 10 Megohms. The ground point shall be local building or green wire ground. As an objective , the dc resistance should exceed 10MΩ.

4.4. Test loops :

This test loop model is valid only for voiceband frequencies.

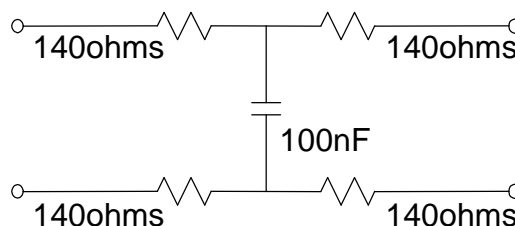

4.5. Electrical Specification :

The low pass filter shall satisfy the following parametric limits shown in this table across the Line side of this device.

Splitter parameter	Electrical requirements	
	Range	values
Splitter bandwidth		DC to 3.4KHz
Nominal voice band		0.2KHz to 4KHz
Ringing frequency		15Hz to 30Hz
ADSL band		30KHz to 1104KHz
Line Impedance ZL	300 Hz < f < 3.4 KHz	600 ohm
Modem impedance	30 KHz < f < 1104 KHz	100 ohm
Operation voltage voice band		
Nominal signal		21mVpp to 5.4 Vpp
Ringing signal		100Vrms
DC voltage		0V to 120V
Max. AC voltage		100Vrms
Max. differential		320V
Line Impedance ZL		600 ohm
CO impedance ZTc		150Ω + (72nF 830Ω)
RT impedance ZTr		150Ω + (72nF (830Ω+1uF))
Current voice band		
Loop current		<=130mA
DC Resistance		
DC Resistance		<=40 ohm
Isolation resistance tip/ring		>10 Mohm
Voice –band characteristic		
Insertion loss	1000Hz	<1.0 dB
Attenuation distortion (relative to 1000Hz)	200Hz<f<3.4KHz	<1.0dB
Attenuation distortion (relative to 1000Hz)	3.4KHz<f<4KHz	<1.5dB
Delay distortion	600Hz<f<3.2KHz	<200 usec
	200Hz<f<4KHz	<250 usec
Return loss	200Hz<f<1.5KHz	>11dB
	1.6KHz<f<2KHz	>10dB
	2.1KHz<f<3.4KHz	>9dB
Longitudinal conversion loss LCL	200Hz to 3.4KHz	>58dB
ADSL modem interface		
Isolation voltage		>2000Vrms for 1 minute
Rejection attenuation at boundary band	4KHz<f<25KHz	>26.48 log ₂ (f / 4) dB
Rejection attenuation at ADSL band	25KHz<f<300KHz	>70dB
	300KHz<f<1104KHz	>55dB
Loading of ADSL signal path	25KHz<f<1104KHz	>0.35dB

4.6. Test method :

4.6.1. Insertion loss :

For each of the test loops specified in above and using the test set-up shown in Figure 1 the insertion loss from the source to the termination shall be measured with and without the splitter/ ZHP-r combination inserted. The increase in insertion loss at 1000 Hz on any of the test loops, due to the addition of the Splitter/ZHP-r shall be less than specified in Electrical Specification table.

The insertion loss of a device connected into a given transmission system is defined as the ratio, expressed in dB, of the load power available (before and after insertion) delivered to the output network beyond the point of insertion at a given frequency. In general , the insertion loss of a device inserted in a given transmission system mainly caused by internal component resistive loss while all of the impedance between source , load and device interface having been matched. To perform the insertion loss measurement ,thru calibration must be done prior the testing . General Insertion loss equation can be expressed as following

$$\text{Insertion loss} = 20 \log \left| \frac{V_2}{V_1} \right| \text{ dB where}$$

V1 = the measured voltage value of load without LPF in circuit.

V2 = the measured voltage value of load with LPF in circuit.

The test setup is shown in drawing below. :

Figure 1

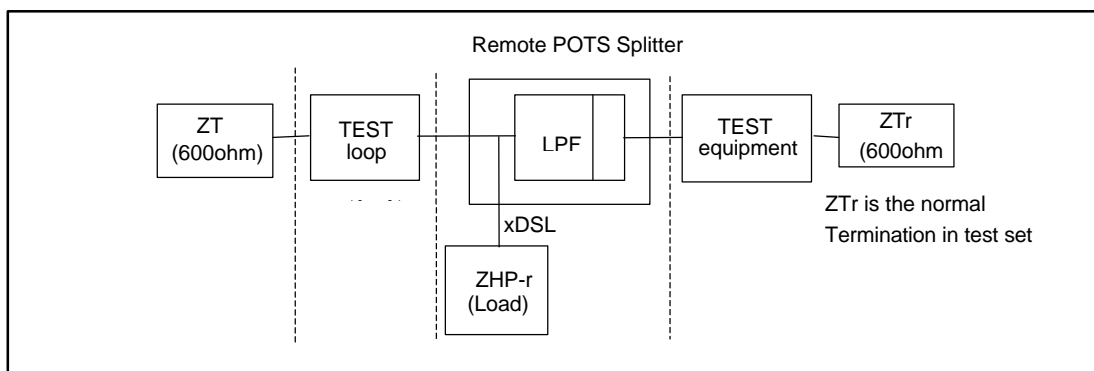

Note : ZHP-r is the impedance presented to the POTS connection by an ATU-R

4.6.2. Return loss for POTS splitter:

The Return Loss is measure of the driving point impedance variation introduced by the filter, variation of the driving point impedance of the loop can affect POTS performance by changing the sidetone balance of a telephone instrument or the front-end hybrid balance of voiceband modem. Return loss measure the amount of energy that is lost due to reflection which resulted from impedance mismatching at the interface. Return loss is essentially defined as the ratio of the power incident upon a given transmission system to the power reflected caused by impedance mismatch with respect to reference impedance at the interface between source and device.

Return loss figure are a function of the impedance of the circuit involved and are therefore frequency dependent. These impedance must be closely maintained in order to reduce the possibility of undesirable reflection and echoes which in long distance circuit the telephone user or destroy the data being sent. To perform the return loss test ,open ,short, load calibration must be done prior measurement while the LCZ impedance Analyzer being selected in impedance mode. Return loss is general expressed in decibels. General Return loss equation as below :

$$\text{Return loss} = 20 \log \left| \frac{Z_{NL-r} - Z_M}{Z_{NL-r} + Z_M} \right| \text{ dB}$$

Where Z_{NL-r} = the reference impedance Z_M = the measured impedance

The test setup is shown in drawing below:

Figure 2

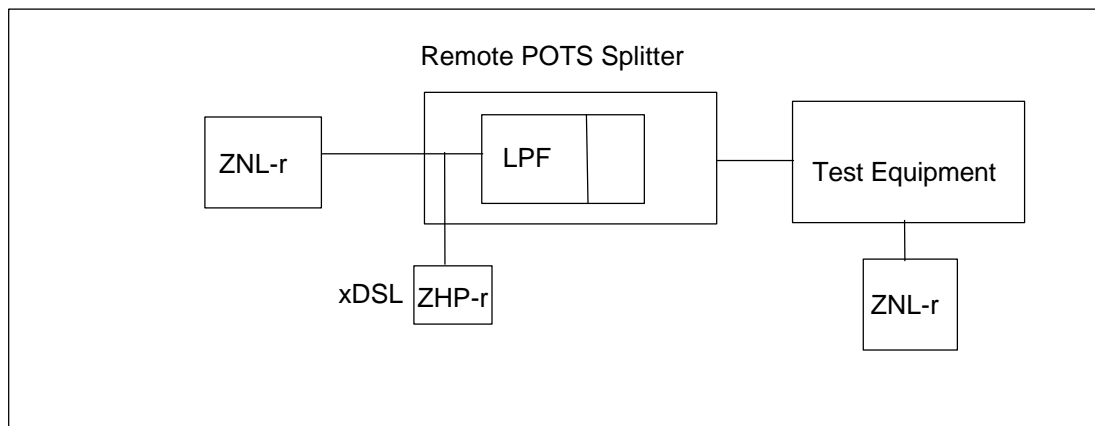

1: $Z_{NL-r} = 150 \text{ ohm} + (72\text{nF} // (830\text{ohms} + 1\text{uF}))$

2: ZHP-r is the impedance presented to the POTS connection by an ATU-R.

4.6.3. Attenuation Distortion in the Voice band :

The variation of insertion loss with frequency shall be measured using the test set up in Fig.1 The defined ZHP-r will be attached to the xDSL port of the Splitter.(if the Splitter is an internal part of the ATU, then the modem remains attached as the xDSL load).The increase in Attenuation Distortion, relative to the 1000 Hz insertion loss caused by the POTS Splitter. Including the ZHP-r (or modem) load attached, using each of the test loops identified above shall be within Electrical Specification table.

5. Environmental condition:

5.1. Resistibility to overvoltages and overcurrents:

The splitter has to comply with requirements as per ITU-T K.21.

5.2. Climatic conditions:

5.2.1. Operating temperature:

Application indoor
Long time operation guarantee temperature (5 to 40 °C)
Short time operation guarantee temperature (0 to 50 °C)
(According to ETS 300 019, class 3.2)

5.2.2. Storage and transport:

Low ambient temperature - 20 °C
High ambient temperature +85 °C
(According to MIL-STD-202 method 107)

5.2.3. Operation humidity:

Long time operation guarantee humidity (5 to 85 %)
Short time operation guarantee humidity (5 to 90 %)
Short time : within 72 continuous hours and 15 days in a year

6. Reliability conditions:

6.1. Thermal shock :

Temperature from -20 °C to +85 °C for 5 cycles
(According to MIL-STD-202 , method 107)

6.2. Temperature humidity exposure :

+50 °C /95RH , 96hrs
(According to MIL-STD-202 , method 103)

6.3. Vibration test :

Random vibration , frequency 5-500Hz , sweep time :1 hr / axis /
Force : 2.4grams (According to MIL-STD-202 , method 204)

7 . Mechanical Condition :

7.1. Mechanical :

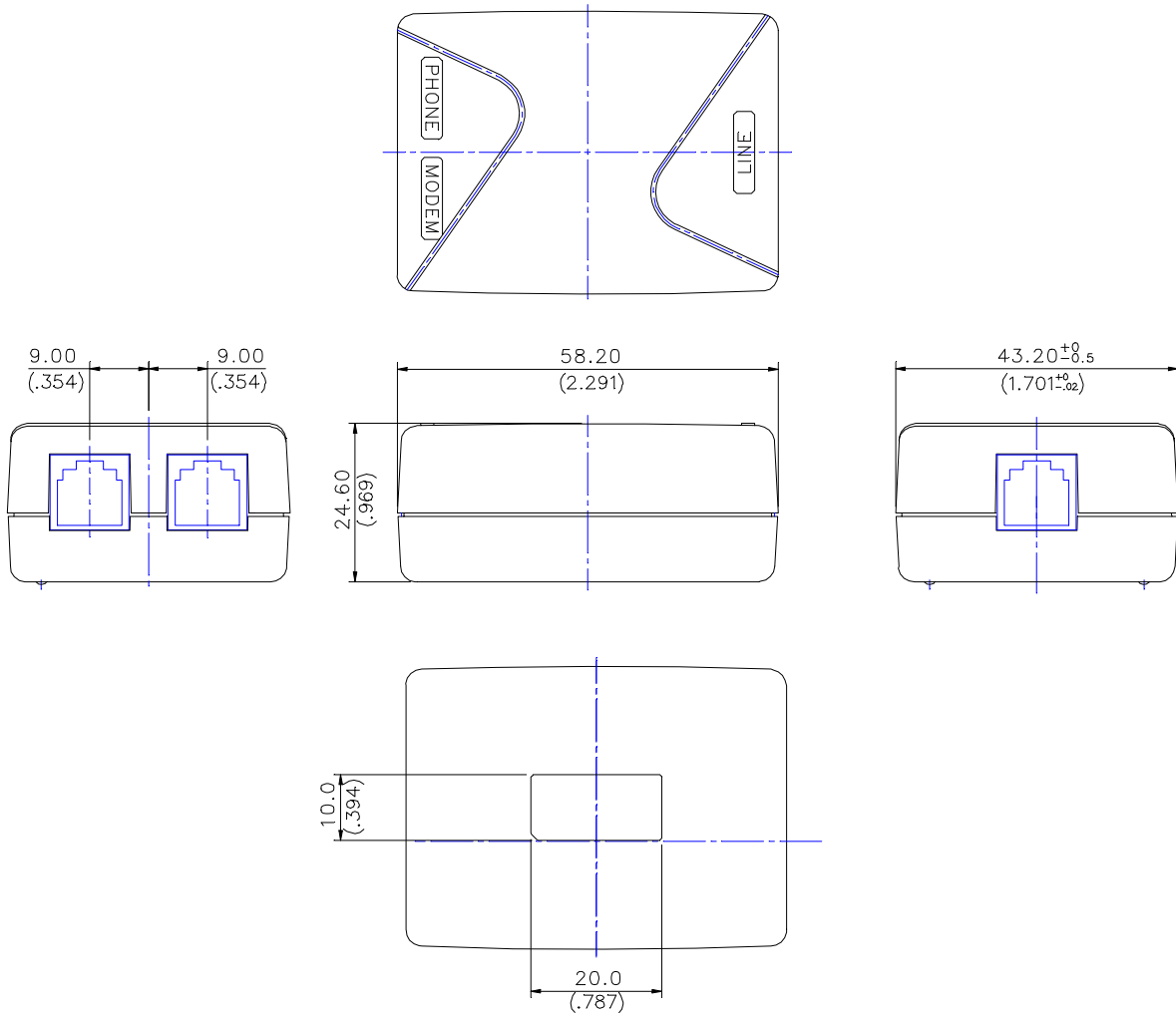

Note : Unit mm

7.2. Connector information :

Function	Style	Tip	Ring
Line	RJ 11	Pin 3	Pin 4
DSL	RJ 11	Pin 3	Pin 4
Phone	RJ 11	Pin 3	Pin 4