

CCD Color-Space Processor with Analog Output

Features

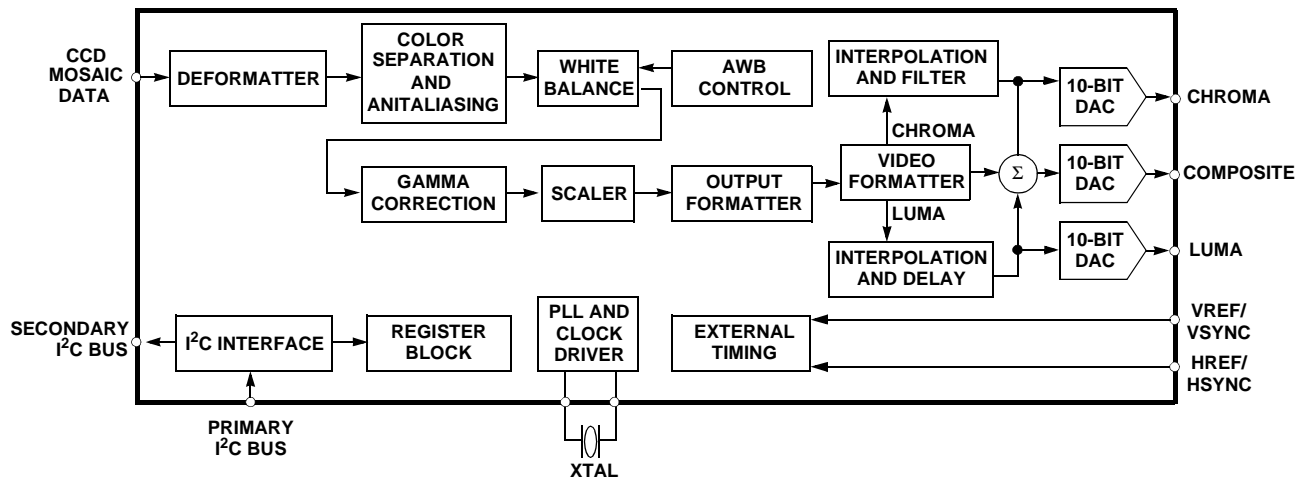
- ITU-601 Compliant Image Formatting
- ITU-656 and SMPTE-125/M Transports
- I²C Control Interface
- Limited Secondary I²C Bus Master
- Automatic White Balance
- Programmable Gamma Correction
- Programmable Interpolation
- Programmable Luma Gain and Saturation Control
- Fully Programmable Color Separation Matrix Coefficients
- Supports up to 1440, active pixels per line, with no limitation on Vertical Size
- Programmable "Chroma Kill" circuit
- Highly integrated for low part count cameras
- Three DACs providing simultaneous composite, S-video outputs
- Multi-standard support for NTSC-M, NTSC-JAPAN, PAL (B, D, G, H, I, M, N, Combination N)
- On-chip voltage reference generator modes, tri-state DACs and power down mode.

Description

The CS7654 is a low-power Digital Color-Space Processor for CCD cameras. It provides all the necessary digital image processing for standard four-color interline transfer CCD imagers. The CS7654 processes the magenta, yellow, cyan, and green (MYCG) CCD imager data into YCrCb formatted component digital video and into analog PAL or NTSC. Internal processing includes color separation, automatic white balance, user programmable gamma correction, programmable scaling (interpolation), digital output formatting and encoding function for analog output. Also, a special "Chroma Kill" circuit eliminates false colors during saturation. Video output can be formatted to be compatible with NTSC-M, NTSC-J, PAL-B,D,G,H,I,M,N, and Combination N systems. Closed Caption is supported in NTSC. Three 10-bit DACs provide two channels for an S-Video output port and one composite video outputs. A High-speed I²C compatible control interface is provided for in system design. A general purpose I/O port is also available to help conserve valuable board space and to provide up to eight "boot" configurations. The CS7654 is designed to work directly with the CS7615 CCD Imager Analog Processor.

ORDERING INFORMATION

CS7654-KQ 0° to 70° C 64-pin TQFP
(10 mm x 10 mm x 1.4 mm)



Preliminary Product Information

This document contains information for a new product. Cirrus Logic reserves the right to modify this product without notice.

TABLE OF CONTENTS

CHARACTERISTICS/SPECIFICATIONS	4
DIGITAL CHARACTERISTICS	4
SWITCHING CHARACTERISTICS	4
POWER CONSUMPTION	5
POWER CONSUMPTION	6
CONTROL PORT CHARACTERISTICS	6
RECOMMENDED OPERATING CHARACTERISTICS	7
ABSOLUTE MAXIMUM RATINGS	7
GENERAL DESCRIPTION	8
Overview	8
Digital Output Formats	11
Internal Horizontal Scaler	11
CLKIN2X Input Timing	12
CLKOUT_GRG	12
INTERNAL PROCESSING	13
Input Data Format and Chroma Separator	13
White Balance and Gamma Correction	13
Chroma Kill	13
Internal Filters	14
Analog Video Timing Generator	14
Color Subcarrier Synthesizer	14
Chroma Path	14
Luma Path	14
Digital to Analog Converters	15
Voltage Reference	15
Current Reference	15
Closed Caption Insertion	15
Control Registers	16
Testability	16
OPERATIONAL DESCRIPTION	16
Reset Hierarchy	16
Vertical Timing	16
NTSC Interlaced	17
PAL Interlaced	18
Progressive Scan	18
Digital Video Input Modes	18
Multi-standard Output Format Modes	20
Subcarrier Generation	20
Color Bar Generator	20
Super White/Super Black support	21
FILTER RESPONSES	23

Preliminary product information describes products which are in production, but for which full characterization data is not yet available. Advanced product information describes products which are in development and subject to development changes. Cirrus Logic, Inc. has made best efforts to ensure that the information contained in this document is accurate and reliable. However, the information is subject to change without notice and is provided "AS IS" without warranty of any kind (express or implied). No responsibility is assumed by Cirrus Logic, Inc. for the use of this information, nor for infringements of patents or other rights of third parties. This document is the property of Cirrus Logic, Inc. and implies no license under patents, copyrights, trademarks, or trade secrets. No part of this publication may be copied, reproduced, stored in a retrieval system, or transmitted, in any form or by any means (electronic, mechanical, photographic, or otherwise). Furthermore, no part of this publication may be used as a basis for manufacture or sale of any items without the prior written consent of Cirrus Logic, Inc. The names of products of Cirrus Logic, Inc. or other vendors and suppliers appearing in this document may be trademarks or service marks of their respective owners which may be registered in some jurisdictions. A list of Cirrus Logic, Inc. trademarks and service marks can be found at <http://www.cirrus.com>.

INTERNAL REGISTER STRUCTURE AND USER INTERFACE	25
Operating CS7654 in Normal I2C Configuration (Three-Byte Mode)	25
Station Address	25
Write Operations in Three-Byte Mode	25
Address Set Operation	26
Read Operations in Three-Byte Mode	26
Operating CS7654 in Four-Byte I2C Configuration	26
Write Operations in Four-Byte mode	26
Read Operations in Four-Byte Mode	27
Initializing Slave Devices on Secondary I2C bus from an EPROM	27
Controlling the Configuration Process	28
Reserved Registers and Test Pins	29
General Purpose I/O Port	29
ANALOG	30
Analog Timing	30
VREF	30
ISET-DAC	30
DACs	30
Luminance DAC	30
Chrominance DAC	31
COMP_VID DAC	31
REGISTER DESCRIPTION	32
BOARD DESIGN AND LAYOUT CONSIDERATIONS	53
Power and Ground Planes	53
Power Supply Decoupling	53
Digital Interconnect	53
Analog Interconnect	53
Analog Output Protection	54
ESD and Latch up Protection	54
External DAC Output Filter	54
PIN DESCRIPTIONS	55
PACKAGE DIMENSIONS	60

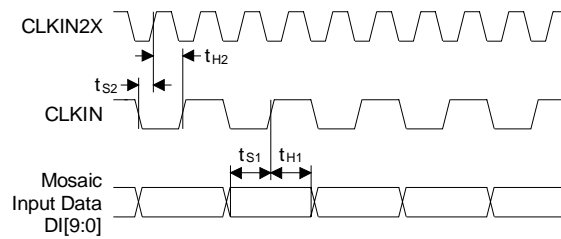
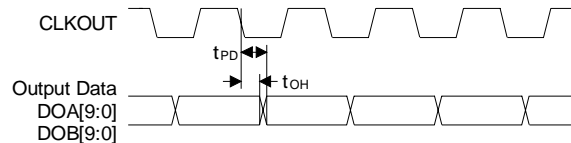
CHARACTERISTICS/SPECIFICATIONS
DIGITAL CHARACTERISTICS ($T_A = 25\text{ }^\circ\text{C}$; $V_{DD} = 5\text{ V}$; $C_L = 30\text{ pF}$; Input Levels: logic 0 = 0 V, logic 1 = V_{DD} .)

Parameter	Symbol	Min	Typ	Max	Unit
Logic Inputs					
High-Level Input Voltage	V_{IH}	$V_{DD} - 0.8$	-	-	V
Low-Level Input Voltage	V_{IL}	-	-	0.8	V
Input Leakage Current	I_{IN}	-	-	10.0	μA
Input Pin Capacitance	C_{DI}	-	10	-	pF
Input Clamp Voltage		-	-0.7	-	V
Logic Outputs					
High-Level Output Source Current @ $I_{OH} = 1\text{ mA}$	V_{OH}	$V_{DD} - 0.4$	-	-	V
Low-Level Output Sink Current @ $I_{OL} = 1\text{ mA}$	V_{OL}	0.4	-	-	V
High-Z Leakage Current	I_Z	-	-	10.0	μA

SWITCHING CHARACTERISTICS ($T_A = 25\text{ }^\circ\text{C}$; $V_{DD} = 5\text{ V}$; $C_L = 30\text{ pF}$; Input Levels: logic 0 = 0 V, logic 1 = V_{DD} .)

Parameter	Symbol	Min	Typ	Max	Unit
Digital Input					
CLKIN2X Frequency Range	f_{CLK2X}	-	27	30	MHz
Input Data setup time, DI[9:0]	t_{S1}	5	-	-	ns
Input Data hold time, DI[9:0]	t_{H1}	5	-	-	ns
Digital Output					
Channel A/B Digital Data Output Clock	Interleaved Data f_{CLKOUT_GRG}	-	-	30	MHz
Channel A/B Output Hold Time	t_{OH}	-	0	-	ns
Channel A/B Output Propagation Delay	t_{PD}	-	1.9	5	ns
Digital Output Rise Time with 30 pF load	t_R	-	15	-	ns
Digital Output Fall Time with 30 pF load	t_F	-	15	-	ns

Specifications are subject to change without notice


Input Timing Diagram

Output Timing Diagram
POWER CONSUMPTION ($T_A = 25\text{ }^\circ\text{C}$; $V_{DD} = 5\text{ V}$; $C_L = \text{no load}$; Input Levels: logic 0 = 0 V, logic 1 = V_{DD} .)

Parameter	Symbol	Min	Typ	Max	Unit
Power Supply					
Supply Voltage	VAA	4.75	5.0	5.25	V
Digital Supply Current (Encoder)	IAA1	-	70		mA
Analog Supply (Encoder) Low-Z (Note 1)	IAA2	-	100	-	mA
Power Supply Rejection Ratio	PSRR	-	0.02	0.05	%/%
Normal Mode	I_{DD}	-	150	200	mA
Low Power Mode	I_{DD}	-	7	16	mA
Analog Outputs					
Full Scale Output Current COMP_VID/Y/C (Notes 2, 3)	IO	32.9	34.7	36.5	mA
Full Scale Output Current COMP_VID/Y/C (Notes 2, 4)	IO	8.22	8.68	9.13	mA
LSB Current COMP_VID/Y/C (Notes 2, 3)	IB	32.2	33.9	35.7	mA
LSB Current COMP_VID/Y/C (Notes 2, 4)	IB	8.04	8.48	8.92	mA
DAC-to DAC Matching	MAT	-	2	-	%
Output Compliance	VOC	0	-	+ 1.4	V
Output Impedance	ROUT	-	15	-	k Ω
Output Capacitance	COUT	-	-	30	pF
DAC Output Delay	ODEL	-	4	12	nsec
DAC Rise/Fall Time (Note 5)	TRF	-	2.5	5	nsec

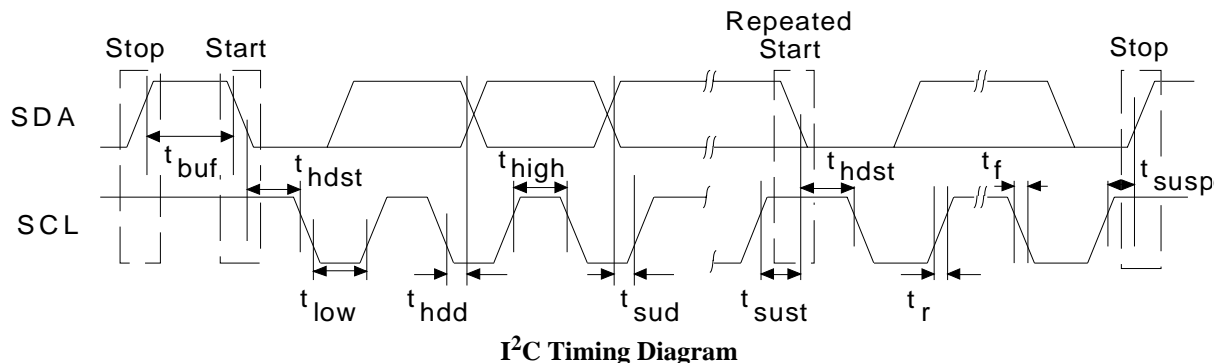
- Notes:
1. Low-Z - 3 dacs on
 2. Output current levels with ISET = 4 K Ω , VREF = 1.232 V.
 3. DACs are set to low impedance mode
 4. DACs are set to high impedance mode
 5. Times for black-to-white-level and white-to-black-level transitions.

POWER CONSUMPTION (Continued)

Parameter	Symbol	Min	Typ	Max	Units
Voltage Reference					
Reference Voltage Output	VOV	1.170	1.232	1.294	V
Reference Input Current	UVC	-	-	10	uA
Static Performance					
DAC Resolution		-	-	10	Bits
Differential Non-Linearity	DNL	-1	± 0.5	+1	LSB
Integral Non-Linearity	INL	-2	± 1	+2	LSB
Dynamic Performance					
Differential Gain	DG	-	2	5	%
Differential Phase	DP	-	± 0.5	± 2	deg
Hue Accuracy	HA	-	-	2	deg
Signal to Noise Ratio	SNR	70	-	-	dB
Saturation Accuracy	SAT	-	1	2	%

CONTROL PORT CHARACTERISTICS ($T_A = 25\text{ }^\circ\text{C}$; $V_{DD} = 5\text{ V}$; Input Levels: logic 0 = 0 V, logic 1 = V_{DD} .)

Parameter	Symbol	Min	Max	Unit
SCL Clock Frequency	f_{SCL}	-	400	kHz
Bus Free Time Between Transmissions	t_{buf}	1.3	-	μs
Start Condition Hold Time	t_{hdst}	0.6	-	μs
Clock Pulse Width	High t_{high}	0.6	-	μs
	Low t_{low}	1.3	-	μs
Setup Time for Repeat Start Condition	t_{sust}	0.6	-	μs
SDAIN Hold Time from SCL Falling	t_{hdd}	0	-	μs
SDAIN Setup Time from SCL Rising	t_{sud}	0.1	-	μs
SDAIN and SCL Rise Time	t_r	-	1.0	μs
SDAIN and SCL Fall Time	t_f	-	0.3	μs
Setup Time for Stop Condition	t_{susp}	0.6	-	μs



RECOMMENDED OPERATING CHARACTERISTICS

Parameter	Symbol	Min	Typ	Max	Unit
Power Supply Voltage	V_{DD}	4.5	5.0	5.5	V
Ground to Ground Voltage Differential		-	-	10	mV
Digital Input Rise/Fall Time		-	-	10	ns
CLKIN Level Setup to CLKIN2X Rising (non-interpolated)	t_{S2}	8	-	-	ns
CLKIN Level Hold after CLKIN2X Rising (non-interpolated)	t_{H2}	8	-	-	ns
Digital Input Voltage Range		0	-	V_{DD}	V
Operating Temperature Range	T_A	0	-	70	°C

ABSOLUTE MAXIMUM RATINGS

Parameter	Symbol	Min	Max	Unit
Power Supply Voltage	V_{DD}	-0.3	6.0	V
Digital Input Voltage Range		GND - 0.3	$V_{DD} + 0.3$	V
Forced Digital Output Current		-	50	mA
Sustained Digital Output Voltage		GND - 0.3	$V_{DD} + 0.3$	V
Output Short Circuit Current		-	-	mA
Operating Temperature Range	T_A	0	70	°C
Lead Solder Temperature (10 s duration)		-	+260	°C
Storage Temperature Range		-65	+160	°C

WARNING: Operation at or beyond these limits may result in permanent damage to the device.
Normal operation is not guaranteed at these extremes.

GENERAL DESCRIPTION

Overview

The CS7654 is a complete color space converter and multi-standard digital video encoder implemented in current CMOS technology. It provides all necessary digital image processing for standard four-color interline transfer CCD imagers. The CS7654 processes the magenta, yellow, cyan, and green (MYCG) CCD imager data into YCrCb formatted component and into NTSC-M, NTSC-J, PAL-B, PAL-D, PAL-G, PAL-H, PAL-I, PAL-M, PAL-N, or PAL-N Argentina-compatible analog video.

Two 10-bit DAC outputs provide high quality S-Video analog output while another 10-bit DAC simultaneously generates composite analog video.

In order to lower overall system costs, the CS7654 provides an internal voltage reference that eliminates the requirement for an external, discrete, three-pin voltage reference.

The CS7654 forms the heart of a four chip digital CCD Camera. The four chips include the CCD imager, the CS7615 CCD digitizer, the CS7654 color space processor, and a vertical drive interface-chip for the CCD imager. Most four-phase CCD imagers (and their associated vertical drives) can be used with the CS7615 digitizer and the CS7654 processor to form a simple and cost-effective Analog output format digital camera. The CS7615 and CS7654 together support imager formats ranging from 175×175 pixels up to 1000×1000 pixels. Timing control is located in the CS7615 analog processor, while the CS7654 synchronizes itself by decoding the timing cues embedded in the CS7615 data stream. Alternately, the CS7654 accepts horizontal and vertical timing signals on HREFIN and VREFIN pins. The block diagram in Figure 1 illustrates a typical system interconnect.

The CS7654 provides color separation of standard MYCG chroma block data from industry standard

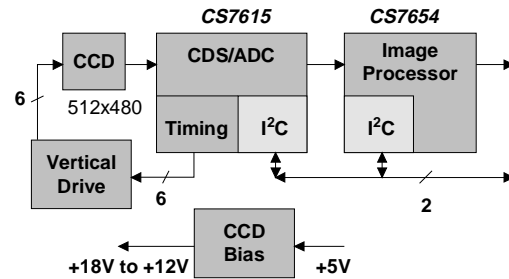


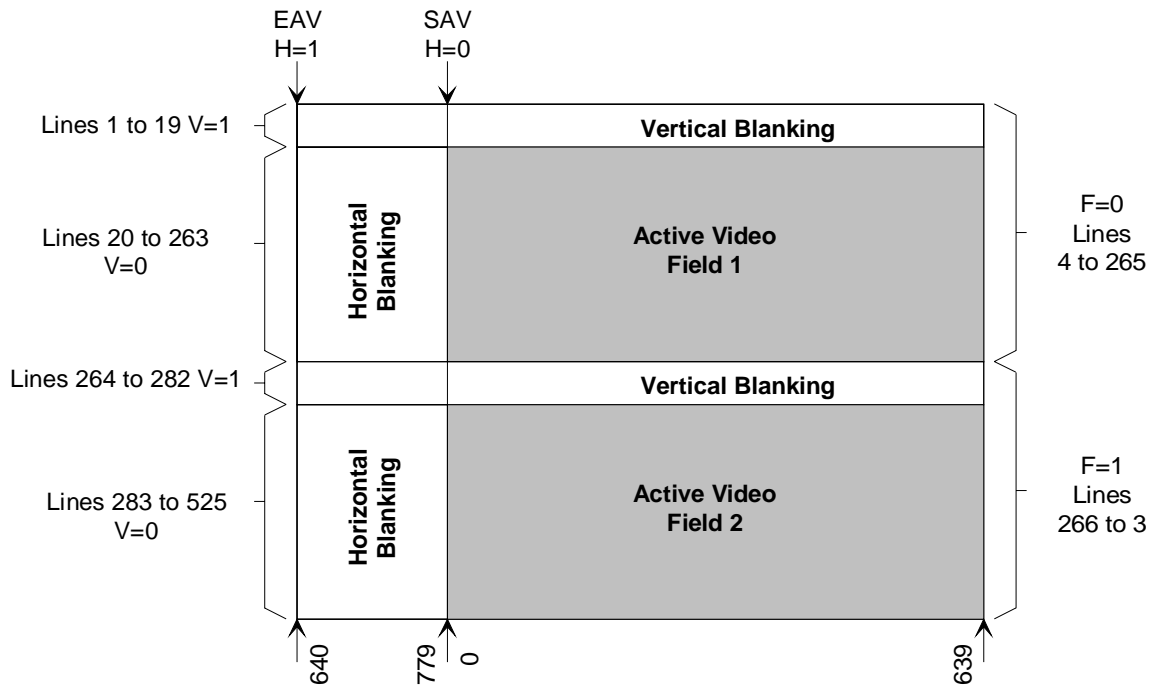
Figure 1. Typical 4-Chip Digital CCD Camera

four-color CCD imagers. Gamma correction and white balance adjustment functions are also included in the CS7654. The YCrCb (luminance and chrominance) data is output at twice the scaled pixel rate in 10-bit format. The digital YCrCb output data from the CS7654 conforms to the ITU-656 parallel component digital video recommendation with embedded synchronization (see Embedded EAV and SAV discussion).

The CS7654 incorporates an internal horizontal scaler which may be turned on to increase the horizontal pixel count of the popular 360 (CIF) and 512 horizontal pixel per line imagers. The most common target resolutions for the scaler are 640 and 720 pixels per line (square and rectangular pixel formats), but it is possible to provide generic scaling of M/N where M and N are values from 1 to 31.

The CS7615 and CS7654 chip set supports a wide range of imager formats while providing an output format that follows the ITU-601 Component Digital Video recommendation. The ITU-601 document primarily specifies horizontal resolutions of 720 active horizontal pixels (which is required for broadcast television compatibility). However, many of today's digital video receivers are capable of operating with a wide range of video image formats. Even though these digital video receivers allow image formats not specified in the ITU-601/656 recommendation, all of these receivers expect the basic ITU-601/656 protocol to be followed in terms of data sequence and timing cues. This is the case with the CS7654, where all output formats

follow the ITU-601/656 recommendation even if the image formats differ in horizontal and vertical pixel dimensions.



**Figure 2. Horizontal and Vertical Timing States
(640x480 resolution)**

Word	Data Content		Pixel	Notes	
1280	1111	1111	640	EAV	
1281	0000	0000		EAV	
1282	0000	0000		EAV	
1283	1FV1	P3P2P1P0		641	EAV
1284	1000	0000		642	For pixels 642 to 777 Cr = Cb = 80h Y = 10h
1285	0001	0000			
1286	1000	0000			
1287	0001	0000		643	
1552	1000	0000	776		
1553	0001	0000			
1554	1000	0000			
1555	0001	0000		777	
1556	1111	1111	778	SAV	
1557	0000	0000			
1558	0000	0000			
1559	1FV0	P3P2P1P0		779	SAV
0		Cb0	0	Start of Digital Video	
1		Y0		For VBLANK line 1 to 19 and 264 to 283 Cr = Cb = 80h Y = 10h	
2		Cr0			
3		Y1			
4		Cb2			
5		Y2		For active pixels 20 through 263 and 283 to 525 for n=even from pixels 0 to 638	
6		Cr2			
7		Y3			
2n		Cbn			
2n + 1		Yn	n		
2n + 3		Crn			
		Yn+1	n+1		
1272		Cb636	636		
1273		Y636			
1274		Cr636	637		
1275		Y637			
1276		Cb638	638		
1277		Y638			
1278		Cr638			
1279		Y639		End of Digital Video	

Table 1. Detail of Scan Line for 640x480 Image

Digital Output Formats

The CS7654 can output data in a 10-bit format at a 2x output pixel clock rate. Figure 3 details the clock and data relationships. The output data transitions on the falling edge of the clock such that the rising edge of the clock can be used to latch the data into subsequent circuitry.

The CS7654 delivers 4:2:2 component digital video output data in YCrCb format. The data conforms to the ITU-R BT.656 specification. The Y component range is 16-235 (8-bit data) and the Cr and Cb component ranges are 16-240 (8-bit data). However, by setting CLIP_OFF (register 07h bit 6 at SA34h) to a value of 1, the output data can be extended to a range of 1-254 (8-bit data). Only 00 and FF are restricted to allow digital timing codes. The CLIP_OFF register will set the digital section on the data path to the extended range of value. If you want to have the analog output set to extended range, you will also have to set Register 06h at Station Address (SA) 0x00.

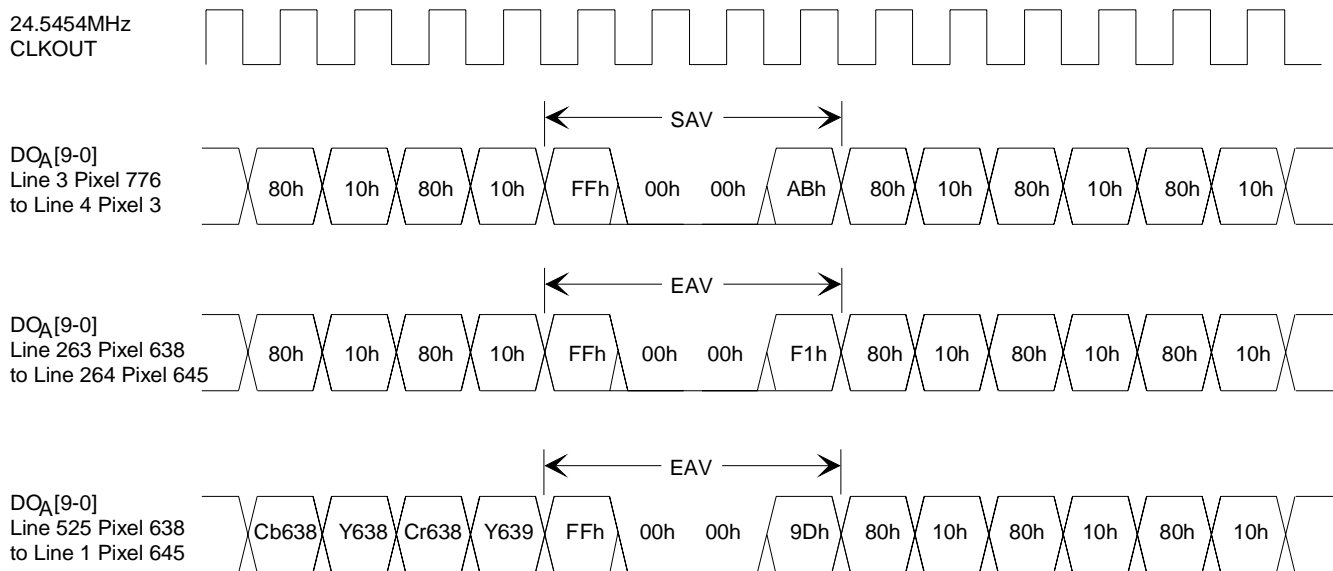
The digital outputs are configured for 10-bit interleaved Y and CrCb data

The CS7654 supports both 8-bit and 10-bit operation as per the ITU-656 recommendation. The ITU-656 recommendation defines the primary data path as 8-bits wide with two additional fractional bits that can be used to form a 10-bit data path. If only 8-bits of output data are used, the two LSBs, DOUT1 and DOUT0 are not used. However, DOUT[9:2] is connected exactly the same as in a 10-bit system. This is essential to properly pass the image data and synchronization signals to the next component.

Internal Horizontal Scaler

The internal horizontal scaler is used to bridge between common CCD imager formats and computer or television formats.

Several pre-defined scaler modes may be selected by writing a 3-bit value to bits 0-2 of register 04h at SA 0x34h. These default scaling modes are described in Table 2. If the CUSTOM bit (bit 3 of register 04h at SA 0x34h) is set to a 1, then the scaling ratio is determined by the M and N values contained in the Scaler Control registers (2Dh - 2Fh at SA 0x34h.)



NOTE: EAV, SAV, and Blanking data values are based on the 8 MSB's of the output data, the two LSBs are considered fractional.

Figure 3. 2x Pixel Clock, 10-Bit interleaved Output Format for 640x480 Image Format.

CLKIN2X Input Timing

The CLKIN2X, pin 59, will always require a primary pixel rate clock source. CCD manufacturers generally specify a pixel clock frequency that is compatible with one of the analog encoders that can be used with a given imager. If the analog output is used, the clock frequency input must be matched precisely. However, digital display systems, such as those based on VGA graphics adapter cards and Zoom Video systems, are generally not sensitive to pixel clock frequency, and will tolerate a wide range of pixel and frame rates.

Specific pixel-rate clock frequencies for analog encoders include 14.31818 MHz for 768H imagers, the primary ITU-601 13.5 MHz for 720H imagers, and down to 12.272727 MHz clock rates for 640H VGA format imagers.

CLKOUT_GRG

CLKOUT_GRG follows the output data rate. The clock output is at 2x the output luma sample rate, there is no non-interlaced digital output on the CS7654.

Mode	CCD Format	CCD Clock (MHz)	Output Format	Input Clock (MHz)	Scaling Ratio
000	CCD	½ input clock	same as CCD	(30 MHz max.)	1:1
001	512x480	9.818	640x480	24.5454	4:5
010	512x480	9.346	720x480	27.000	9:13
011	512x576	9.281	720x480	27.000	11:16
100	362x480	6.75	640x480	24.5454	11:20
101	362x480	6.75	720x480	27.000	1:2
	362x576	6.75	720x576	27.000	
110	512x576	9.563	720x576	27.000	17:24
111	512x480	9.000	720x480	27.000	2:3
	512x576	9.000	720x576	27.000	

Table 2. Default Scaling Modes (Register 04h at SA34h)

INTERNAL PROCESSING

The internal operation of the CS7654 can be separated into several distinct blocks. The following section provides an overview of how these blocks operate and interact.

Input Data Format and Chroma Separator

The CS7654 accepts up to 10-bit MYCG image data from a CCD digitizer such as the CS7615. The CS7654 internally converts the four-color CCD MYCG interlaced image data into the various color space formats. These include RGB and YUV, as well as YCrCb. The individual image adjustments are performed in the most appropriate color space representation. Ultimately the image is converted to YCrCb format for outputting digital data. The same digital output data is also encoded in the digital video encoder post processor section and converted to analog NTSC or PAL.

White Balance and Gamma Correction

The red and blue color balances can be adjusted through the I²C control port. During the AWB (automatic white balance) sequence the red level is adjusted to minimize the (Y-R) difference component; similarly the blue level is adjusted to minimize the (Y-B) color difference component. An automatic white balance is initiated by writing a 1 to register 05h bit 1 at SA 0x34h. For manual control, the red balance is accessed through register 08h, and the blue balance is accessed through register 09h (both at SA 0x34h).

Gamma correction is provided to offset the non-linear illumination profile of the display device. Separate 256 entry tables are supplied for red, green, and blue. Each entry is 8-bits. The gamma table is programmed through register 0Ch at SA 0x34h. The write format is similar to the write format described in the normal I²C operation section later in this document. The first byte contains the CS7654 device address and write bit, the second byte con-

tains the CS7654 gamma table register address (0Ch), the third byte determines which gamma RAM to update (red, green, and blue), the next 256 bytes contain the gamma table entries.

The blue gamma RAM is selected by setting register 0Ch bit 0 to a one; the green gamma RAM is selected by setting register 0Ch bit 1 to a one; and the red gamma RAM is selected by setting register 0Ch bit 2 to a one. Any, or all of the gamma RAMs may be selected. The most common implementation is to write the same gamma table to all 3 RAMs by setting bits 0-2 high. The gamma table itself is loaded from low to high. The first byte after the RAM selection byte will correspond to the value used when the input data is 00h, the 256th byte after the RAM selection byte will correspond to the value used when the input data is FFh.

The gamma table is read in a similar manner. However, certain restrictions are made to reads. First, the gamma RAMs may only be read one at a time (RAM selection byte = 01,02,04 only) and, second, the gamma table may only be read when gamma correction is disabled (register 05 bit2 = 0).

Chroma Kill

As the brightness of an image increases, the green, yellow, cyan, and magenta pixels within the CCD array will saturate at different intensity levels. As a result, a highly illuminated object or light source may start to look cyan. To overcome this effect, an internal Chroma kill circuit compares the luma and chroma values of each pixel to a set of programmable thresholds. If the pixel's luma value is greater than the Y_THR value (register 27h at SA 0x34h) and its Cr and Cb values are between the CR_THR_H, CR_THR_L, CB_THR_H, and CB_THR_L threshold values respectively, then that pixel will lose its chroma value (become white.) These thresholds are stored in registers 27h - 2Ch at SA 0x34h.

Internal Filters

The CS7654 has an internal low-pass chroma filter to reduce the effects of color aliasing. This filter is enabled by writing a value of 0 to bit 4 of register 01h at SA 0x00h. The CS7654 also contains a luma peaking filter to enhance the edges of blurred images. This filter is enabled by setting register 05h bit 3 to a value of 0 at SA 0x34h. By default the low-pass chroma filter is off and the peaking filter is on.

Analog Video Timing Generator

All timing generation is accomplished via a 27 MHz input applied to the CLKIN2X pin.

The Video Timing Generator is responsible for orchestrating most of the other modules in the device. It automatically disables color burst on appropriate scan lines and automatically generates serration and equalization pulses on appropriate scan lines.

Color Subcarrier Synthesizer

The subcarrier synthesizer is a digital frequency synthesizer that produces the appropriate subcarrier frequency for NTSC or PAL. The CS7654 generates the color burst frequency based on the CLK input (27 MHz). Color burst accuracy and stability are limited by the accuracy of the 27 MHz input. If the frequency varies, then the color burst frequency will also vary accordingly.

Controls are provided for phase adjustment of the burst to permit color adjustment and phase compensation. Chroma hue control is provided by the CS7654 via a 10-bit Hue Control Register (HUE_LSB and H_MSB). Burst amplitude control is also made available to the host via the 8-bit burst amplitude register (SC_AMP). Horizontal sync to color burst phase adjust is possible by programming the SCH register (register 17h, SA 00h).

Chroma Path

The Video Input Formatter delivers 4:2:2 YUV outputs into separate chroma and luma data paths. The chroma path will be discussed here.

The chroma output of the Video Input Formatter is directed to a chroma low-pass 19-tap FIR filter. The filter bandwidth is selected (or the filter can be bypassed) via the CONTROL_1 Register. The passband of the filter is either 650 KHz or 1.3 MHz and the passband ripple is less than or equal to 0.05 dB. The stopband for the 1.3 MHz selection begins at 3 MHz with an attenuation of greater than 35 dB. The stopband for the 650 KHz selection begins around 1.1 MHz with an attenuation of greater than 20 dB.

The output of the chroma low-pass filter is connected to the chroma interpolation filter in which up-sampling from 4:2:2 to 4:4:4 is accomplished. Following the interpolation filter, the U and V chroma signals pass through two independent variable gain amplifiers in which the chroma amplitude can be varied via the U_AMP and V_AMP 8-bit host addressable registers.

The U and V chroma signals are fed to a quadrature modulator in which they are combined with the output from the subcarrier synthesizer to produce the proper modulated chrominance signal.

The chroma then is interpolated by a factor of two in order to operate the output DACs at twice the pixel rate. The interpolated filters enable running the DACs at twice the pixel rate and this helps reduce the $\sin x/x$ roll-off for higher frequencies and reduces the complexity of the external analog low pass filters.

Luma Path

Along with the chroma output path, the CS7654 Video Input Formatter initiates a parallel luma data path by directing the luma data to a digital delay line. The delay line is built as a digital FIFO in which the depth of the FIFO replicates the clock period delay associated with the more complex chroma path. Brightness adjustment is also provided via the 8-bit BRIGHTNESS_OFFSET Register.

Following the luma delay, the data is passed through an interpolation filter that has a programmable bandwidth, followed by a variable gain amplifier in which the luma dc values are modifiable via the Y_AMP Register.

The output of the luma amplifier connects to the sync insertion block. Sync insertion is accomplished by multiplexing, into the luma data path, the different sync dc values at the appropriate times. The digital sync generator takes horizontal sync and vertical sync timing signals and generates the appropriate composite sync timing (including vertical equalization and serration pulses), blanking information, and burst flag. The sync edge rates conform to RS-170A or ITU R.BT601 and ITU R.BT470 specifications.

It is also possible to delay the luminance signal, with respect to the chrominance signal, by up to three pixel clocks. This variable delay is useful to offset different propagation delays of the luma baseband and modulated chroma signals. This adjustable luma delay is available only on the COMP_VID output.

Digital to Analog Converters

The CS7654 provides three discrete 27 MHz DACs for analog video. The default configuration is one 10-bit DAC for S-video chrominance, one 10-bit DAC for S-Video luminance, one 10-bit DAC for composite output. All three DACs are designed for driving either low-impedance loads (double terminated 75 Ω) or high-impedance loads (double terminated 300 Ω).

The DACs can be put into tri-state mode via host-addressable control register bits. Each of the six DACs has its own associated DAC enable bit. In the Disable Mode, the 10-bit DACs source (or sink) zero current.

For lower power standby scenarios, the CS7654 also provides power shut-off control for the DACs. Each DAC has an associated DAC shut-off bit.

Voltage Reference

The CS7654 is equipped with an on-board voltage reference generator (1.232 V) that is used by the DACs. The internal reference voltage is accurate enough to guarantee a maximum of 3% overall gain error on the analog outputs. However, it is possible to override the internal reference voltage by applying an external voltage source to the VREF pin.

Current Reference

The DAC output current-per-bit is derived in the current reference block. The current step is specified by the size of resistor placed between the ISET_DAC current reference pin and electrical ground.

A 4 k Ω resistor needs to be connected between ISET_DAC pin and GND. The DAC output currents are optimized to either drive a doubly terminated load of 75 Ω (low impedance mode) or a double terminated load of 300 Ω (high impedance mode). The 2 output current modes are software selectable through a register bit. Note that there are two ISET pins on the device, one for the DACS, and one for the PLL.

Closed Caption Insertion

The CS7654 is capable of NTSC Closed Caption insertion on lines 21 and 284 independently. Closed captioning is enabled for either one or both lines via the CC_EN [1:0] Register bits and the data to be inserted is also written into the four Closed Caption Data registers. The CS7654, when enabled, automatically generates the seven cycles of clock run-in (32 times the line rate), start bit insertion (001), and finally insertion of the two data bytes per line. Data low at the video outputs corresponds to 0 IRE and data high corresponds to 50 IRE.

There are two independent 8-bit registers per line (CC_21_1 & CC_21_2 for line 21 and CC_284_1 & CC_284_2 for line 284). Interrupts are also provided to simplify the handshake between the driver

software and the device. Typically the host would write all 4 bytes to be inserted into the registers and then enable closed caption insertion and interrupts. As the closed caption interrupts occur the host software would respond by writing the next two bytes to be inserted to the correct control registers and then clear the interrupt and wait for the next field.

Control Registers

The control and configuration of the CS7654 is accomplished primarily through the control register block. All of the control registers are uniquely addressable via the internal address register. The control register bits are initialized during device RESET.

See the Programming section of this data sheet for the individual register bit allocations, bit operational descriptions, and initialization states.

The registers of the CS7654 are located in two separate Station Address (SA), the first one at 0x00h and the second one at 0x34h. Be careful to select the proper SA when accessing register because some registers have the same address but are located in a different Station Address. Note that both sections of this device cannot bear the same I²C address.

Testability

The digital circuits are completely scanned by an internal scan chain, thus providing close to 100% fault coverage.

OPERATIONAL DESCRIPTION

Reset Hierarchy

The CS7654 is equipped with an active low asynchronous reset input pin, $\overline{\text{RESET}}$. $\overline{\text{RESET}}$ is used to initialize the internal registers and the internal state machines for subsequent default operation. See the electrical and timing specification section of this data sheet for specific CS7654 device RESET and power-on signal timing requirements and restrictions.

While the $\overline{\text{RESET}}$ pin is held low, the host interface in the CS7654 is disabled and will not respond to host-initiated bus cycles. All outputs are valid after a time period following $\overline{\text{RESET}}$ pin low.

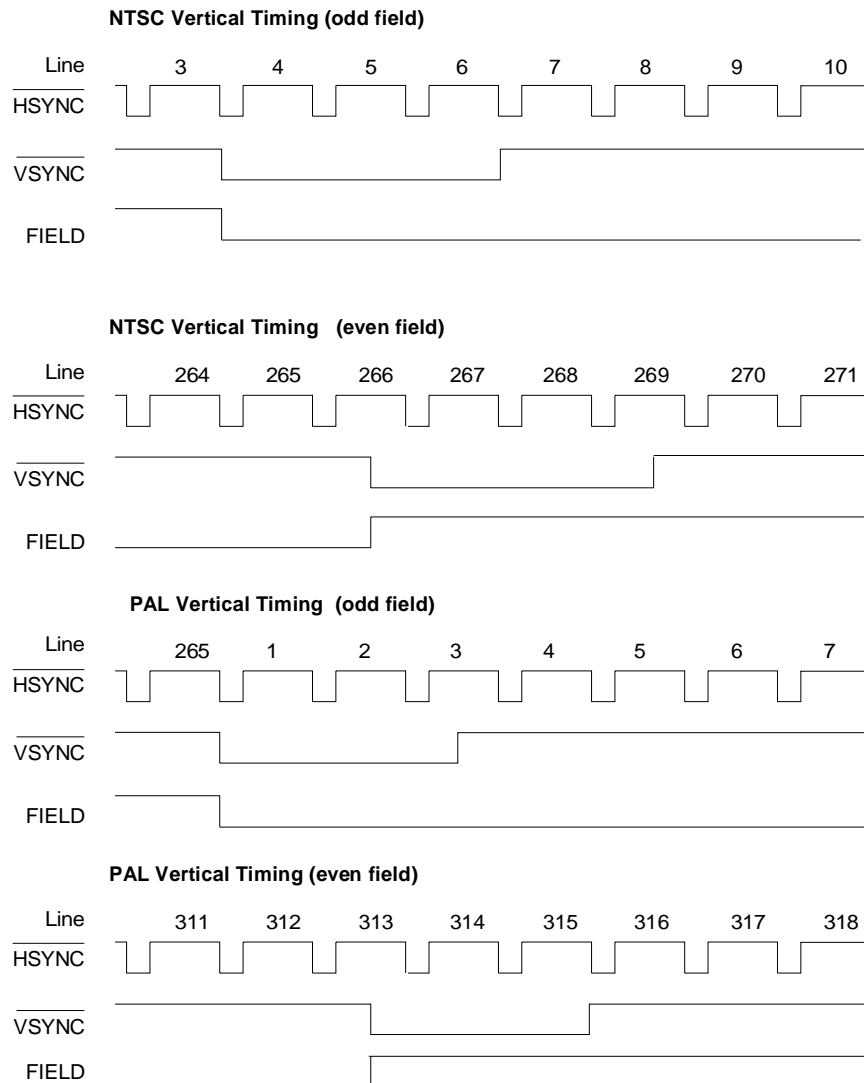
A device RESET initializes the CS7654 internal registers to their default values as described by Table 13 and 14, Control Registers. In the default state, the CS7654 video DACs are disabled and the device is internally configured to provide blue field video data to the DACs (any input data present on the V [7:0] pins is ignored at this time). Otherwise, the CS7654 registers are configured for NTSC-M ITU R.BT601 output operation. At a minimum, the DAC Registers 0x04 and 0x05 at Station Address 0x00 must be written (to enable the DACs) and the IN_MODE bit of the CONTROL_0 SA 0x00, Register (0x00) must be set (to enable ITU R.BT601 data input on V [7:0]) for the CS7654 to become operational after RESET.

Vertical Timing

The CS7654 encoder section can be configured to operate in any of four different analog timing modes: PAL, which is 625 vertical lines, 25 frames per second interlaced; NTSC, which is 525 vertical lines, 30 frames per second interlaced; and either PAL or NTSC in Progressive Scan, in which the display is non-interlaced. These modes are selected in the CONTROL_0 Register (0x00) at SA 0x00h. Note that there are several digital mode (scaler settings) which will not have an equivalent analog timing mode.

The CS7654 conforms to standard digital decompression dimensions and does not process digital input data for the active analog video half lines as they are typically in the over/underscan region of televisions. 240 active lines total per field are processed for NTSC, and 288 active lines total per field are processed for PAL. Frame vertical dimensions are 480 lines for NTSC and 576 lines for PAL. Table 3 specifies active line numbers for both NTSC and PAL.

Mode	Field	Active Lines
NTSC	1, 3; 2, 4	22-261; 285-524
PAL	1, 3, 5, 7; 2, 4, 6, 8	23-310; 336-623
NTSC Progressive-Scan	NA	22-261
PAL Progressive-Scan	NA	23-310

Table 3. Vertical Timing

Figure 4. Vertical Timing

NTSC Interlaced

The CS7654 supports analog NTSC-M, NTSC-J and PAL-M modes where there are 525 total lines per frame and two fixed 262.5-line fields per frame and 30 total frames occurring per second. NTSC in-

terlaced vertical timing is illustrated in Figure 5. Each field consists of one line for closed caption, 240 active lines of video, plus 21.5 lines of blanking.

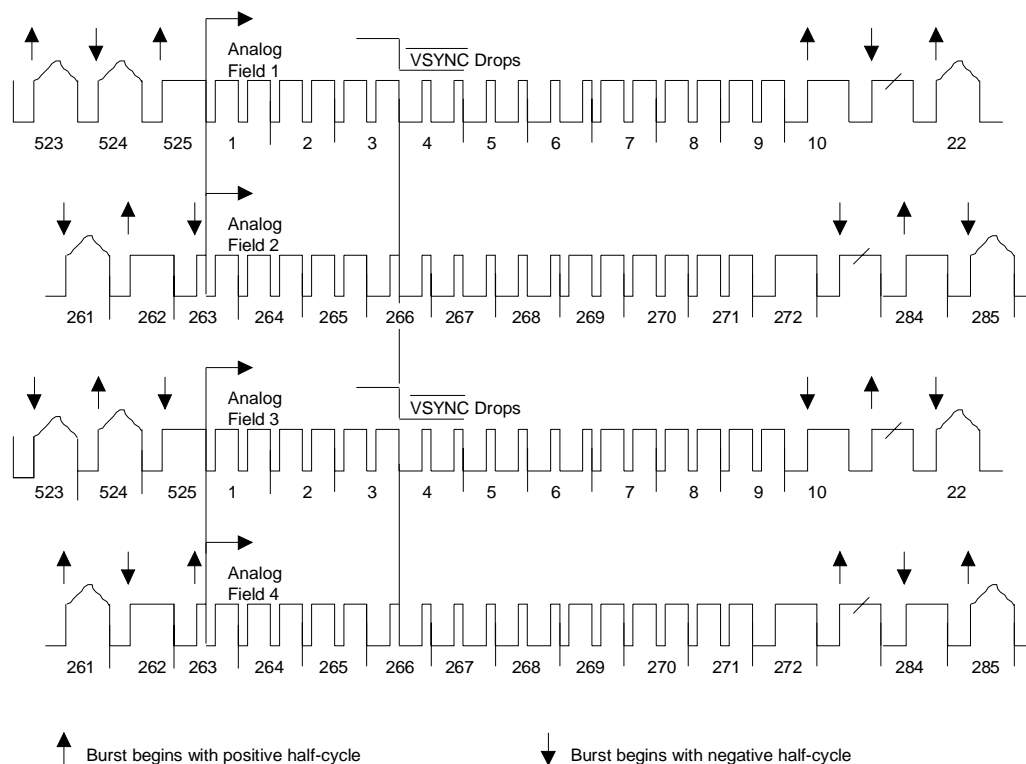


Figure 5. NTSC Video Interlaced Timing

PAL Interlaced

The CS7654 supports analog PAL modes B, D, G, H, I, N, and Combination N, in which there are 625 total lines per frame, two fixed 312.5 line fields per frame, and 25 total frames per second. Figure 7 illustrates PAL interlaced vertical timing. Each field consists of 287 active lines of video plus 25.5 lines.

Progressive Scan

The CS7654 supports an analog progressive scan mode in which the video output is non-interlaced. This is accomplished by displaying only the odd video field for NTSC or PAL. To preserve precise MPEG-2 frame rates of 30 and 25 per second, the CS7654 displays the same odd field repetitively but alternately varies the field times. This mode is in contrast to other digital video encoders, which commonly support progressive scan by repetitively displaying a 262 line field (524/525 lines for

NTSC). The common method is flawed: over time, the output display rate will overrun a system-clock-locked MPEG-2 decompressor and display a field twice every 8.75 seconds. NTSC non-interlaced timing is illustrated in Figure 7. PAL non-interlaced timing is illustrated in Figure 8.

Digital Video Input Modes

The CS7654 provides two different digital video input modes that are selectable through the IN_MODE bit in the CONTROL_0 Register at SA 0x00.

In Mode 0 and upon RESET, the CS7654 defaults to output a solid color (one of a possible of 256 colors). The background color is selected by writing the BKG_COLOR Register (0x08) at SA 0x00. The colorspace of the register is RGB 3:3:2 and is unaffected by gamma correction. The default color following RESET is blue.

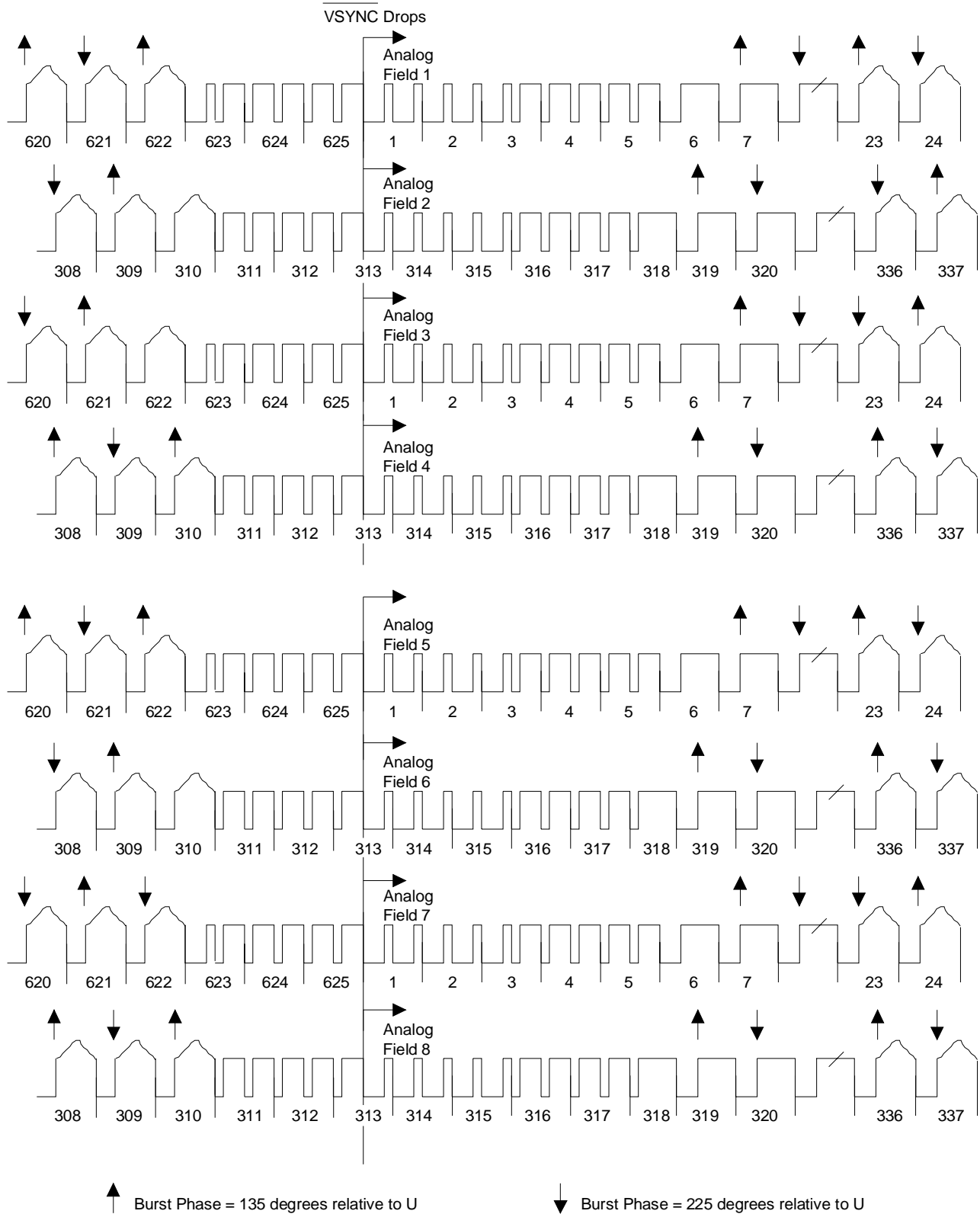


Figure 6. PAL Interlaced Timing

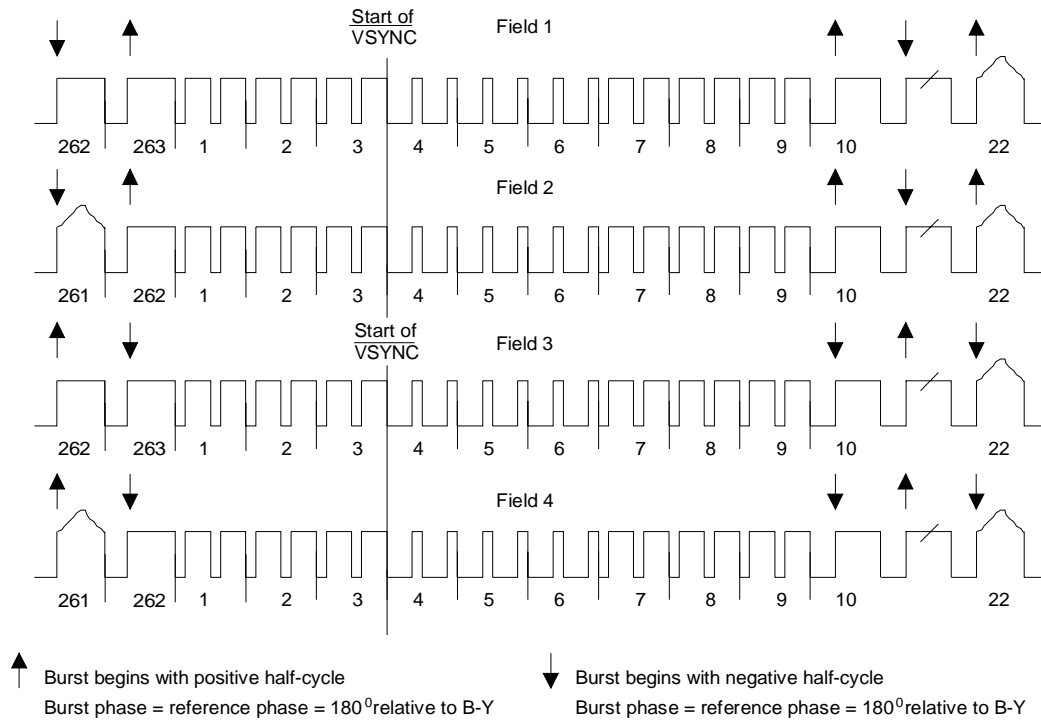


Figure 7. NTSC Video Non-Interlaced Progressive Scan Timing

In mode 1 the CS7654 displays the image captured by the camera.

Multi-standard Output Format Modes

The CS7654 supports a wide range of analog output formats compatible with worldwide broadcast standards. These formats include NTSC-M, NTSC-J, PAL-B/D/G/H/I, PAL-M, PAL-N, and PAL Combination N (PAL-Nc) which is the broadcast standard used in Argentina. After RESET, the CS7654 defaults to NTSC-M operation with ITU R.BT 601 analog timing. NTSC-J can also be supported in the Japanese format by turning off the 7.5 IRE pedestal through the PED bit in the CONTROL_1 Register (0x01) at SA 0x00.

Output formats are configured by writing control registers with the values shown in Table 5.

Subcarrier Generation

The CS7654 automatically synthesizes NTSC and PAL color subcarrier clocks using the CLK frequency and four control registers

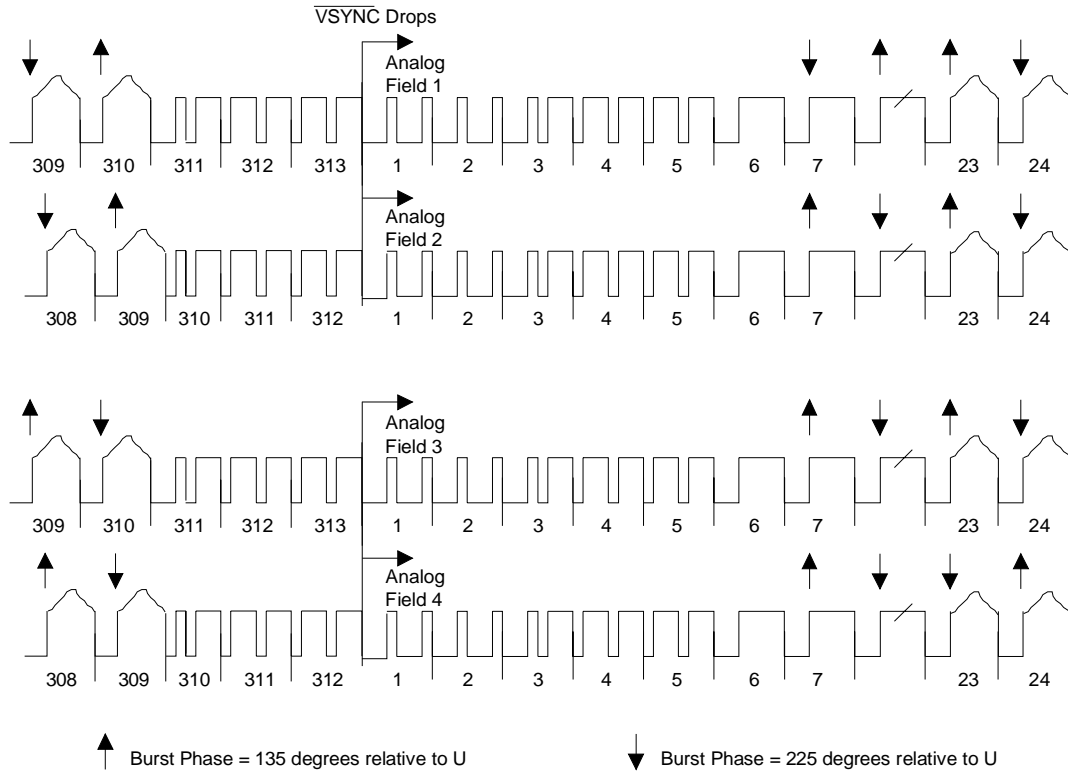
(SC_SYNTH0/1/2/3). The NTSC subcarrier synthesizer is reset every four fields (every eight fields for PAL).

The SC_SYNTH0/1/2/3 registers used together provide a 32-bit value that defaults to NTSC (43E0F83Eh) following RESET. Table 4 shows the 32-bit value required for each of the different broadcast formats.

Color Bar Generator

The CS7654 is equipped with a color bar generator that is enabled through the CBAR bit of the CONTROL_1 Register located at SA 0x00. The color bar generator works in master Mode only and has no effect on the video input/output timing. The color bar generator will override the video input pixel data.

The output of the color bar generator is instantiated after the chroma interpolation filter and before the luma delay line. The generated color bar numbers are for 100% amplitude, 100% saturation NTSC EIA color bars or 100% amplitude, 100% satura-


Figure 8. PAL Video Non-Interlaced Progressive Scan Timing

System	Fsubcarrier	Value (hex)
NTSC-M, NTSC-J	3.5795455 MHz	43E0F83E
PAL-B, D, G, H, I, N	4.43361875 MHz	54131596
PAL-N (Argentina)	3.582056 MHz	43ED288D
PAL-M	3.579611 MHz	43CDDFC7

Table 4.

tion PAL EBU color bars. For PAL color bars, the CS7654 generates NTSC color bar values, which are very close to standard PAL values.

Super White/Super Black support

The ITU-R BT.601 recommendation limits the allowed range for the digital video data between 0x10 - 0xEB (16 - 235) for luma and between 0x10 - 0xF0 (16 - 240) for the chrominance values. This chip will clip any digital input value which is

out of this range to conform to the ITU-R BT.601 specifications.

However for some applications it is useful to allow a wider input range. By setting the CLIP_OFF bit (CONTROL_6 register at Station Address 0x00) the allowed input range is extended between 0x01 - 0xFE (1 - 254) for both luma and chrominance values.

Address for SA 0x00	Register	NTSC-M ITU R.BT601	NTSC-J ITU R.BT601	NTSC-M RS170A	PAL-B,D,G,H,I	PAL-M	PAL-N	PAL-N Comb. (Argent)
0x00	CONTROL_0	01h	01h	21h	41h	61h	A1h	81h
0x01	CONTROL_1	12h	10h	16h	30h	12h	30h	30h
0x04	CONTROL_4	07h	07h	07h	07h	07h	07h	07h
0x05	CONTROL_5	78h	78h	78h	78h	78h	78h	78h
0x10	SC_AMP	1Ch	1Ch	1Ch	15h	15h	15h	15h
0x11	SC_SYNTH0	3Eh	3Eh	3Eh	96h	C7h	96h	8Ch
0x12	SC_SYNTH1	F8h	F8h	F8h	15h	DFh	15h	28h
0x13	SC_SYNTH2	E0h	E0h	E0h	13h	CDh	13h	EDh
0x14	SC_SYNTH3	43h	43h	43h	54h	43h	54h	43h

Table 5. Multi-standard Format Register Configurations

Note that 0x00 and 0xFF values are never allowed, since they are reserved for synchronization information.

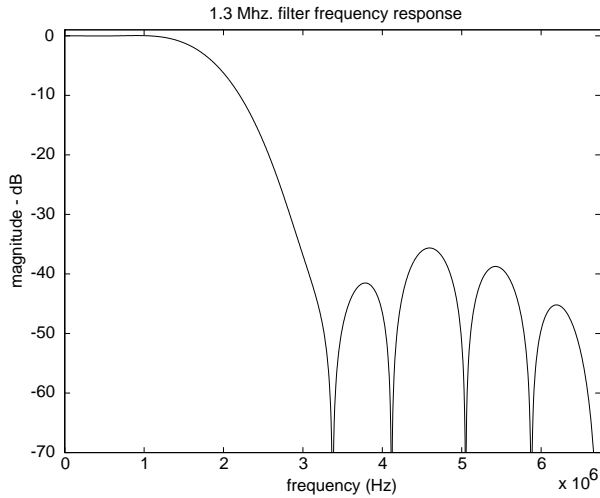
FILTER RESPONSES

Figure 9. 1.3 Mhz Chrominance low-pass filter transfer characteristic

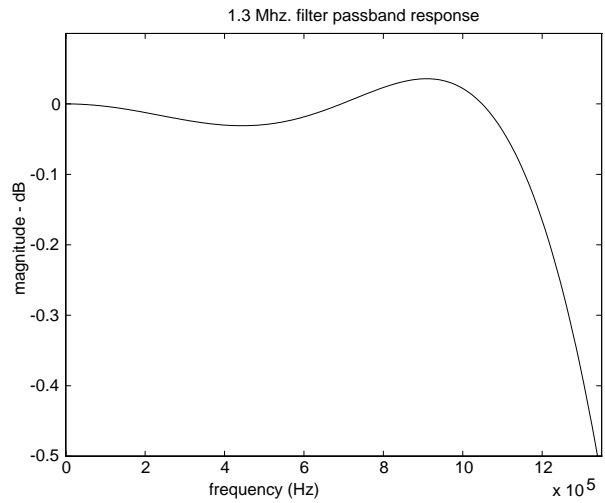


Figure 10. 1.3 Mhz Chrominance low-pass filter transfer characteristic (passband)

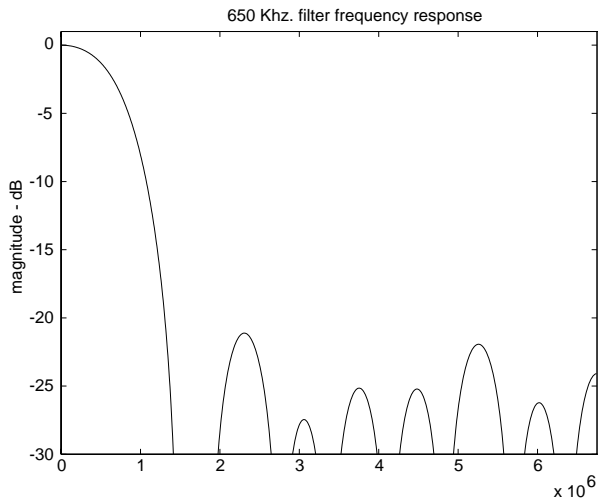


Figure 11. 650 kHz Chrominance low-pass filter transfer characteristic

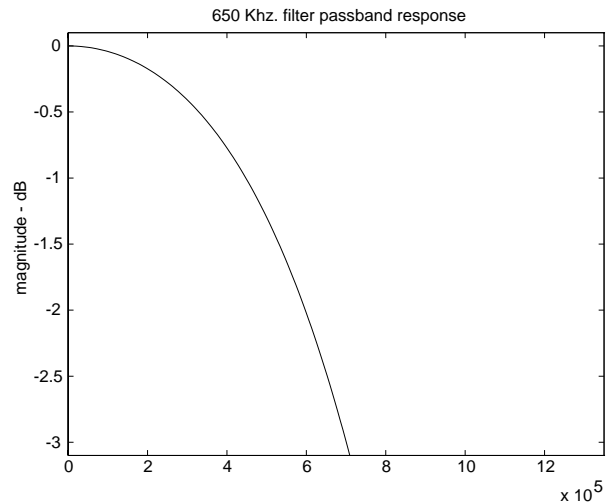


Figure 12. 650 kHz Chrominance low-pass filter transfer characteristic (passband)

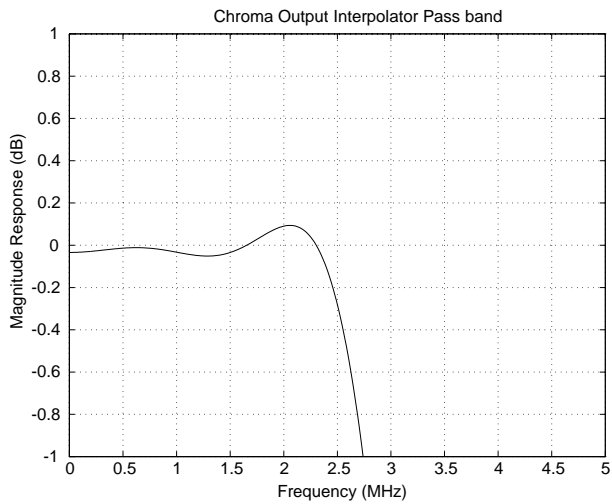


Figure 13. Chrominance output interpolation filter transfer characteristic (passband)

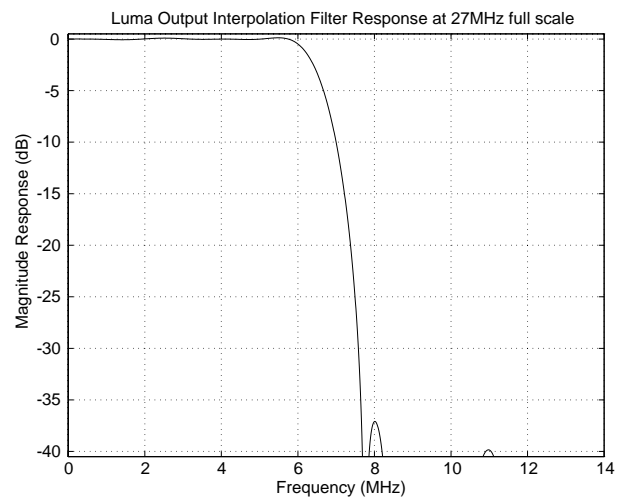


Figure 14. Luminance interpolation filter transfer characteristic

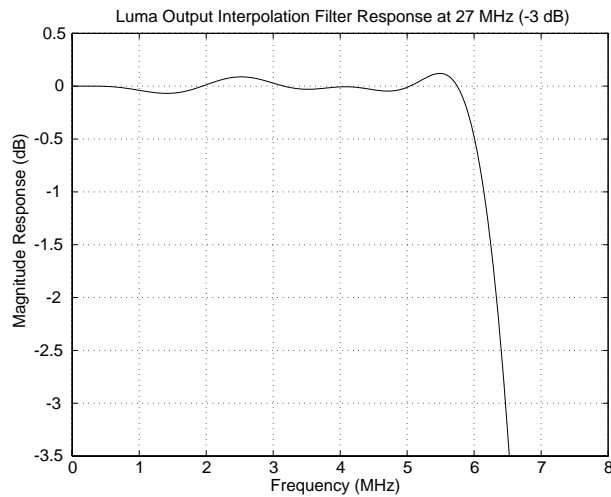


Figure 15. Luminance interpolation filter transfer characteristic (passband)

INTERNAL REGISTER STRUCTURE AND USER INTERFACE

The user interface describes the user's external view of the CS7654 and the basic control operations. These areas include digital data, analog output modes and organization, timing and synchronization signals, I²C interface, and miscellaneous controls.

The CS7654 has two I²C ports: (1) a slave I²C port called the primary I²C port, and (2) a secondary I²C port with limited I²C master capabilities. The primary I²C port allows an external controller to control the CS7654 (See Station Address section for more details on Station Address structure). It is assumed the external controller will also directly control any other I²C slave devices on the camera board. This is the normal I²C operation mode of CS7654. The secondary I²C port, on the other hand, may be used to control all the other slave devices on a camera board through the CS7654 only. This feature is useful when the external I²C controller is used to control multiple cameras. When used in this configuration the P4BYTMODE pin (pin 46) of the CS7654 must be tied high and the device is operated in four-byte mode.

Operating CS7654 in Normal I²C Configuration (Three-Byte Mode)

In normal mode, the CS7654 is connected as a slave device to an external I²C controller through the primary I²C port. The connection is done via a two-wire serial bus. Other I²C devices on the camera may also share the same serial bus. The external controller communicates with the I²C devices by sending and receiving short packets of 8-bit words in accordance with the I²C protocol. The packets contain the station address of the target device, the desired register address, and data.

There are three packet formats: WRITE format, ADDRESS SET format, and READ format. Each packet is addressed to a device by the station ad-

dress. The LSB of the station address is the R/W (data direction) bit. This bit is set LOW in the WRITE and ADDRESS SET packets, and it is set HIGH for READ packets. The master can read and write to non-existent registers within the selected device. WRITE operations will have no effect; READ operations will return a value of 00h.

Station Address

Each device on the I²C bus has a unique 7-bit address. An eighth bit, the R/W bit, determines if the current data transfer writes data to the slave device or reads data from the slave device. It is common to represent the station address and R/W bit as two 8-bit station addresses, one address for write accesses and another address for read accesses. We will follow this practice. Please note that because the register of the CS7654 are physically implemented in two different banks, the use of two different Station Addresses are necessary. Therefore, to access the proper registers you must first select the proper Station Address. Both Station Addresses have to be different from one another or an internal register conflict will occur.

The CS7654 default station address are 34h for writes and 35h for reads for the color processing section and 00h and 01h for the encoder portion of the CS7654. The station address can be changed by writing a new station address to register FFh. The value written to this register does not include the R/W bit. For example. The default station address (34h write / 35h read) will be stored as 1Ah in register FFh.

Write Operations in Three-Byte Mode

The WRITE format consists of a three-byte packet. The first byte is the station address with the data direction bit set LOW to indicate a write. The second byte is the device register address (0..255). The third byte is the register data (0..255). No additional bytes are allowed.

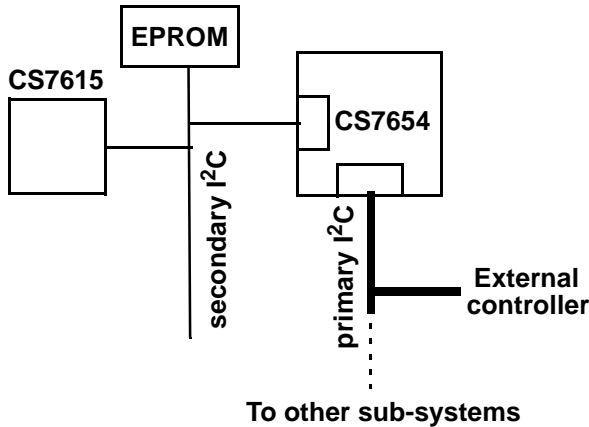


Figure 16. I²C configuration showing primary and secondary I²C busses.

Byte Sequence	WRITE Format Packet Detail
First Byte	Station Address with LSB Set LOW
Second Byte	Device Register Address (0..255)
Third Byte	Register Data (0..255)

Table 6. WRITE Format Packet

Address Set Operation

The ADDRESS SET format consists of a two-byte packet which sets the address of a subsequent READ operation. The first byte of the Station Address with the LSB (data direction bit) set LOW to indicate a write operation. The second byte is the register address (0..255). The ADDRESS SET format is the same as the WRITE format, without the register data (third byte).

Byte Sequence	ADDRESS SET format Packet Details
First Byte	Station Address with LSB Set LOW
Second Byte	Device Register Address (0..255)

Table 7. ADDRESS SET Format Packet Operation

Read Operations in Three-Byte Mode

The READ operation may consist of two or more bytes. The first byte is the station address with the LSB (data direction bit) set HIGH indicating a read operation. The addressed device then sends one or more bytes back from the register last addressed by

the previous WRITE operation or the previous ADDRESS SET operation.

Byte Sequence	READ Format Packet Details
First Byte	Station Address with LSB set HIGH; Source Device then Returns One Byte of Register Data (0..255)
Second Byte	Returned data from CS7654

Table 8. READ Format Packet.

Operating CS7654 in Four-Byte I²C Configuration

In this configuration the external controller talks only to the CS7654 through the primary I²C interface. All the other slave devices on the camera board are tied to the secondary I²C port of the CS7654. WRITE and READ packets only are defined in four-byte mode. Independent address set operations to slave devices on the secondary I²C bus is not allowed in four-byte mode. Four-byte mode is active when the P4BYTMODE pin (pin 46) is logic high.

Write Operations in Four-Byte mode

All WRITE operations from an external controller, through the CS7654, to any slave device must use the four-byte mode; this includes writing to the CS7654 itself. The external controller sends a four-byte WRITE command to the CS7654 which initiates a WRITE operation to the destination slave device and sets the I2CBUSY bit in the status register (01h at SA 0x34h). The I2CBUSY bit is cleared when the write operation on the secondary bus is complete. The External controller can poll the status register to check if the CS7654 has completed the command.

The CS7654 has a one-command-buffer which allows the external controller to queue one additional command while the current command is still being executed. If more than one command is sent before the I2CBUSY bit is cleared, the CS7654 saves only the last command and executes it after the current one is completed. Commands that involve writing

or reading only to CS7654 registers are not put in the queue but are executed immediately without affecting any transactions occurring on the master I²C interface.

Any attempt by the external I²C controller to write to the CS7654 registers while the CS7654 is busy initializing from an external EEPROM will be ignored. However, reads from the CS7654 are allowed during this time.

If, during a READ or WRITE operation to a slave device, the CS7654 fails to receive an acknowledge bit the execution of the command is aborted and the NODEV bit in the status register is set high. This bit remains set unless it is explicitly cleared by writing to it or a new command is written to CS7654.

Byte Sequence	WRITE Format Packet Detail
First Byte	Station Address of CS7654 with LSB Set LOW
Second Byte	Station Address of target slave device with LSB Set LOW
Third Byte	Device Register Address (0..255)
Fourth Byte	Register Data (0..255)

Table 9. Four-byte WRITE Format Packet

Read Operations in Four-Byte Mode

The READ operation in four-byte mode first requires a three-byte READ-TRIGGER packet to the CS7654. The first byte is the station address of the CS7654 with the LSB set LOW. The second byte is the target slave device's station address with the LSB (data direction bit) set HIGH. The third byte is the register address (0..255).

Byte Sequence	READ-TRIGGER format Packet Details
First Byte	CS7654 Station Address with LSB Set LOW
Second Byte	Target device Station Address with LSB Set HIGH
Third Byte	Device Register Address (0..255)

Table 10. READ-TRIGGER packet in four-byte mode

The READ-TRIGGER packet initiates a READ operation by the CS7654 from the target slave device on the secondary I²C bus. The status register in the CS7654 may be checked to see if the read operation has been completed. The I2CBUSY bit in status register 01h at SA 0x34h is set to zero when the operation is completed.

On completion of a read cycle from the target device, the CS7654 places the data read into the Slave Data Hold register at address 19h at SA 0x34h. The external controller can read this data through the primary I²C port. This requires first performing an ADDRESS SET operation to set the address to 19h at SA 0x34h and then sending a one-byte station address indicating read to the CS7654. The data from register 19h at SA 0x34h is then returned by the CS7654.

Byte Sequence	WRITE Format Packet Detail
First Byte	Station Address of CS7654 with LSB Set LOW
Second Byte	Station Address of CS7654 with LSB Set LOW
Third Byte	Slave Data Hold reg. address 19h

Table 11. Address Set for Slave Data Hold register in Four-byte mode

Byte Sequence	READ Format Packet Details
First Byte	CS7654 Station Address with LSB set HIGH.
Second Byte	Returned data from register 19h of CS7654

Table 12. READ Format Packet.

Initializing Slave Devices on Secondary I²C bus from an EPROM

An EPROM may be attached to the secondary I²C bus for initialization purposes. Resetting the CS7654 initiates a download of register values from the EPROM into any of the slave devices on the secondary I²C bus. The EPROM is assumed to be at station address A0h. If during initialization, the CS7654 does not receive an acknowledge bit from the EPROM, all transactions with the

EPROM are aborted and the NODEV status bit is set in status register at address 01h at SA 0x34h.

The data within the EPROM is formatted in three-byte packets that represent the destination address, register address, and data. After reading a packet, the CS7654 initiates an I²C bus cycle using the first byte as the device station address, the second byte as the device register address, and the third byte as the data being written to the device. If an acknowledge is received from the target device, the CS7654 will fetch the next 3 bytes from the EPROM and repeat the process. The only exception being the gamma table whose entire 256 bytes is transferred in one I²C write cycle. This process will continue until the total number of packets read equals the value in the EEPROM count register (registers 1Ah and 1Bh at SA 0x34h), a HALT command is executed, or NO ACKNOWLEDGE is received from the target device.

While the CS7654 is downloading from the EPROM, the INITACT bit (register 01h bit3 at SA 0x34h) is set in the status register of CS7654. All attempts to write to CS7654 registers by an external controller will be ignored during this time.

Controlling the Configuration Process

The simplest configuration would consist of an EPROM with one configuration file. In this case, the first commands in the EPROM should write the total number of packets in the EEPROM. This data is written to the EEPROM count high and low byte registers (registers 1Ah and 1Bh at SA 0x34h). Subsequent bytes would contain all the necessary data to configure the camera. This data will be read in a sequential fashion.

If, however, multiple configurations are desired, the EEPROM may be programmed with multiple sets of data, and the CS7654 programmed to select one of 8 configurations. The appropriate configuration is defined by the 3 GPIO[2:0] pins. The CS7654 incorporates 3 commands to handle multiple configurations: SKIP, JUMP, and HALT.

The SKIP command tells the CS7654 to skip to the address within the EEPROM specified by the Configuration Control registers (30h - 3Fh at SA 0x34h). The Configuration Control registers are used in pairs to provide a 11-bit EEPROM address. The Configuration Index Register determines which two of the 8 pairs will be used.

The Configuration Index Register is loaded automatically after reset by the CS7654. The CS7654 will read from the GPIO port. If the read cycle is successful, the Configuration Index Register will contain the state of the lower 3 bits of the parallel I/O port. A set of shunts or DIP switches attached to the I/O port provides a convenient way to select up to 8 configurations. The SKIP command is executed by writing a 1 to bit 1 of the EEPROM Control Register (42h at SA 0x34h).

The JUMP is similar to the SKIP command. The user loads a jump address into the Jump Control Registers (40h and 41h at SA 0x34h) and then executes the JUMP command by setting bit 2 of the EEPROM Control Register (42h at SA 0x34h) to a 1. The jump command may be used to reduce the amount of required EEPROM space by allowing multiple configurations to share common data. For example, three configurations may be necessary to adjust for three different CCD timings, but they may all share a common gamma table.

The HALT command is used to stop the execution of the boot state machine. When all necessary data has been read from the EEPROM, writing a 1 to bit 0 (HALT) of the EEPROM Control Register will safely stop the boot process.

The total number of packets that may be stored in the external EEPROM is 2k/3 or 682 3-byte commands. Gamma table packets contain 259bytes.

A typical map of the EPROM table is shown in Figure 17. The only exception to this organization is data for the CS7654 gamma table. The data for the gamma table is organized as shown in Figure 18.

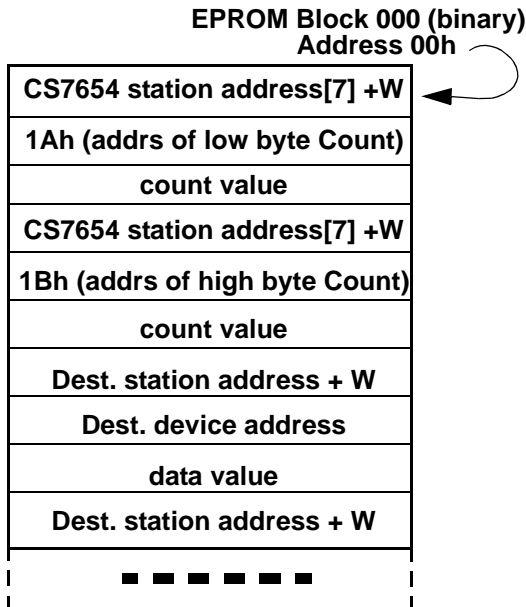


Figure 17. Map of EPROM table for initialization of registers

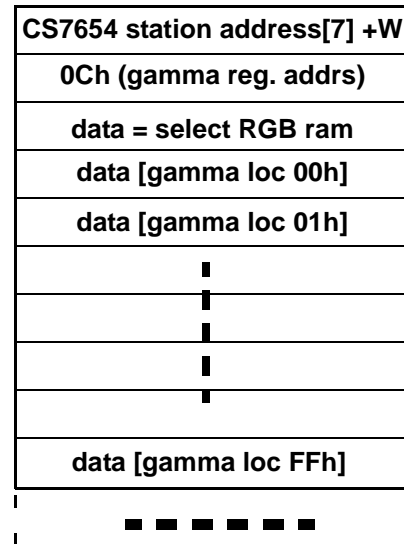


Figure 18. Map of EPROM table for storing gamma ram initialization data.

Reserved Registers and Test Pins

To ensure proper operation of the CS7654, connect and SCENABLE (pin 45) to ground, and connect TEST1 (pin 64) and TEST2 (pin 42) to VDD. Registers 23h - 26h at SA 0x34h must be set to a value of FFh after reset. All other reserved registers may be left in their default states.

General Purpose I/O Port

The CS7654 has a GPIO port and register that is available when the device is configured for I²C host interface operation. The GPIO [2:0] pins operate as input or outputs pins for the GPIO_DATA_REG Register (0x0A at SA 0x00h). The GPIO [2:0] pins are configured for input operation when the corre-

sponding GPIO_CTRL_REG [2:0] bits are set to 0 and output when set to 1. In GPIO input mode, the CS7654 will latch the data on the [2:0] pins into the corresponding bit locations of GPIO_DATA_REG when it detects register address 0x0A at SA 0x00h through the I²C interface. A detection of address 0x0A can happen in two ways. The first and most common way this will happen is when address 0x0A is written to the CS7654 via its I²C interface. The second method for detecting address 0x0A is implemented by accessing register address 0x09 at SA 0x00h through I²C. In I²C host interface operation, the CS7654 register address pointer will auto-increment to address 0x0A after an address 0x09 access (at SA 0x00h).

ANALOG

Analog Timing

All CS7654 analog timing and sequencing is derived from 27 MHz clock input. The analog outputs are controlled internally by the video timing generator in conjunction with master and slave timing. The video output signals perform accordingly for NTSC and PAL specifications.

Being that the CS7654 is almost entirely a digital circuit, great care has been taken to guarantee analog timing and slew rate performance as specified in the NTSC and PAL analog specifications. Reference the Analog Parameters section of this data sheet for exact performance parameters.

VREF

The CS7654 can operate with or without the aid of an external voltage reference. The CS7654 is designed with an internal voltage reference generator that provides a vrefout signal at the VREF pin. The internal voltage reference is utilized by not making a connection to the VREF pin. The VREF pin can also be connected to an external precision 1.232 volt reference, which then overrides the internal reference.

ISET-DAC

All three of the CS7654 digital to analog converter DACs are output current normalized with a common ISET-DAC device pin. The DAC output current per bit is determined by the size of the resistor connected between ISET-DAC pin and electrical ground. Typically a 4 K Ω , 1% metal film resistor should be used. The ISET resistance can be changed by the user to accommodate varying video output attenuation via post filters and also to suit individual preferred performance.

In conjunction with the ISET-DAC value, the user can also independently vary the chroma, luma and colorburst amplitude levels via host addressable

control register bits that are used to control internal digital amplifiers. The DAC output levels are defined by the following operations:

$$\begin{aligned} \text{VREF/RISET} &= \text{IREF} \\ (\text{e.g., } 1.232 \text{ V}/4\text{K } \Omega &= 308 \mu\text{A}) \end{aligned}$$

COMP_VID/Y/C outputs in low impedance mode:

$$\text{VOUT (max)} = \text{IREF} * 112.88 * 37.5 \Omega = 1.304\text{V}$$

COMP_VID/Y/C outputs in high impedance mode:

$$\text{VOUT (max)} = \text{IREF} * 28.22 * 150\Omega = 1.304 \text{ V}$$

DACs

The CS7654 is equipped with three independent, video-grade, current-output, digital-to-analog converters (DACs). They are 10-bit DACs operating at a 27 MHz two-times-oversampling rate. All three DACs are disabled and default to a low power mode upon RESET. Each DAC can be individually powered down and disabled. The output-current-per-bit of all three DACs is determined by the size of the resistor connected between the ISET_DAC pin and electrical ground.

Luminance DAC

The SVID_Y pin is driven from a 10-bit 27 MHz current output DAC that internally receives the SVID_Y, or luminance portion, of the video signal (black and white only). SVID_Y is designed to drive proper video levels into a 37.5 Ω load. Reference the detailed electrical section of this data sheet for the exact SVID_Y digital to analog AC and DC performance data. A EN_L enable control bit in the Control Register 5 (0x05 at SA 0x00h) is provided to enable or disable the luminance DAC. For a complete disable and lower power operation the luminance DAC can be totally shut down via the SVIDLUM_PD control bit in the Control Register 4 (0x04 at SA 0x00h). In this mode, turn-on through the control register will not be instantaneous.

Chrominance DAC

The SVID_C pin is driven from a 10-bit 27 MHz current output DAC that internally receives the SVID_C or chrominance portion of the video signal (color only). SVID_C is designed to drive proper video levels into a 37.5 Ω load. Reference the detailed electrical section of this data sheet for the exact SVID_C digital to analog AC and DC performance data. A EN_C enable control register bit in the Control Register 1 (0x05 at SA 0x00h) is provided to enable or disable the chrominance DAC. For a complete disable and lower power operation the chrominance DAC can be totally shut down via the SVIDCHR_PD register bit in the Control Register 4 (0x04 at SA 0x00h). In this mode turn-on through the control register will not be instantaneous.

COMP_VID DAC

The COMP_VID pin is driven from a 10-bit 27 MHz current output DAC that internally receives a combined luma and chroma signal to provide composite video output. COMP_VID is designed to drive proper composite video levels into a 37.5 Ω load. Reference the detailed electrical section of this data sheet for the exact COMP_VID digital to analog ac and dc performance data. The EN_COM enable control register bit, in Control Register 1 (0x05 at SA 0x00h), is provided to enable or disable the output pin. When disabled, there is no current flow from the output. For a complete

disable and lower power operation, the COMP_VID DAC can be totally shut down via the COMDAC_PD control register bit in Control Register 4 (0x04 at SA 0x00h). In this mode turn-on through the control register will not be instantaneous.

Depending on the external resistor connected to the ISET_DAC pin the output drive of the DACs can be changed. There are two modes in which the DACs should either be operated in. An external resistor of 4 k Ω must be connected to the ISET_DAC pin.

The first mode is the high impedance mode (LOW_IMP bit set to 0). The DAC outputs will then drive a double terminated load of 300 Ω and will output a video signal which conforms to the analog video specifications for NTSC and PAL. External buffers will be needed if the DAC output load differs from 300 Ω .

The second mode is the low impedance mode (LOW_IMP but set to 1). The DAC output will then drive a double terminated load of 75 Ω and will output a video signal which conforms to the analog video specifications for NTSC and PAL. No external buffers are necessary, the outputs can directly drive a television input.

Note If some of the 3 DACs are not used, it is strongly recommended to power them down (see CONTROL_4 register) in order to reduce the power dissipation.

REGISTER DESCRIPTION
Control Registers of encoder section :SA0x00

Address	Register Name	Type	Defaultvalue
0x00	control_0	r/w	01h
0x01	control_1	r/w	02h
0x02	control_2	r/w	00h
0x03	control_3	r/w	00h
0x04	control_4	r/w	3Fh
0x05	control_5	r/w	00h
0x06	control_6	r/w	00h
0x07	RESERVED		
0x08	bkg_color	r/w	03h
0x09	gpio_ctrl_reg	r/w	00h
0x0A	gpio_data_reg	r/w	00h
0x0B - 0x0C	RESERVED		
0x0D	SYNC_0	r/w	90h
0x0E	SYNC_1	r/w	F4h
0x0F	I ² C_ADR	r/w	00h
0x10	SC_AMP	r/w	1Ch
0x11	SC_SYNTH0	r/w	3Eh
0x12	SC_SYNTH1	r/w	F8h
0x13	SC_SYNTH2	r/w	E0h
0x14	SC_SYNTH3	r/w	43h
0x15	HUE_LSB	r/w	00h
0x16	HUE_MSB	r/w	00h
0x17	SCH PHASE ADJUST	r/w	00h
0x18	CC_EN	r/w	00h
0x19	CC_21_1	r/w	00h
0x1A	CC_21_2	r/w	00h
0x1B	CC_284_1	r/w	00h
0x1C	CC_284_2	r/w	00h
0x1D - 0x21	RESERVED		
0x22	CB_AMP	r/w	80h
0x23	CR_AMP	r/w	80h
0x24	Y_AMP	r/w	80h
0x25	R_AMP	r/w	80h
0x26	G_AMP	r/w	80h
0x27	B_AMP	r/w	80h
0x28	BRIGHT_OFFSET	r/w	00h
0x29 - 0x31	RESERVED		
0x32	INT_EN	r/w	00h
0x33	INT_CLR	r/w	00h
0x34	STATUS_0	read only	
0x35 - 0x59	RESERVED		
0x5A	STATUS_1	read only	04h
0x61 - 0x7F	RESERVED		

Table 13. Encoder Control Registers

Control Register 0 at SA 0x00h

Address 0x00 CONTROL_0 Read/Write Default Value = 01h

Bit Number	7	6	5	4	3	2	1	0
Bit Name	TV_FMT			MSTR	CCIR656	PROG	IN_MODE	CBCR_UV
Default	0	0	0	0	1	0	0	1

Bit	Mnemonic	Function
7:5	TV_FMT	selects the TV display format 000: NTSC-M CCIR601 timing (default) 001: NTSC-M RS170A timing 010: PAL-B, D, G, H, I 011: PAL-M 100: PAL-N (Argentina) 101: PAL-N (non Argentina) 110-111: reserved
4	Reserved	Set to 0
3	CCIR656	Set to 1
2	PROG	Progressive scanning enable (enable = 1)
1	IN_MODE	Input select (0 = solid background, 1 = use V [7:0] data)
0	CBCR_UV	enable YCbCr to YUV conversion (1 = enable, 0 = disable)

Control Register 1 at SA 0x00h

Address 0x01 CONTROL_1 Read/Write Default Value = 02h

Bit Number	7	6	5	4	3	2	1	0
Bit Name	LUM_DEL		CH_BW	LPF_ON	res	res	PED	res
Default	0	0	0	0	Reserved	Reserved	1	Reserved

Bit	Mnemonic	Function
7:6	LUM_DEL	luma delay on the composite output 00: no delay (default) 01: 1 pixel clock delay 10: 2 pixel clock delay 11: 3 pixel clock delay
5	CH_BW	chroma lpf bandwidth (0 = 650 kHz, 1 = 1.3 Mhz)
4	LPF_ON	chroma lpf on/off (0 = off, 1 = on)
3	Reserved	Reserved
2	Reserved	Reserved
1	PED	Pedestal offset (0: 0 IRE, 1: 7.5 IRE)
0	Reserved	Reserved

Control Register 2 at SA 0x00h

Address 0x02 CONTROL_2 Read/Write Default Value = 00h

Bit Number	7	6	5	4	3	2	1	0
Bit Name	res	res	res	res	res	res	res	BU_DIS
Default	Reserved							0

Bit	Mnemonic	Function
7:1	Reserved	Set to 0
0	BU_DIS	Chroma burst disable (1 = disable)

Control Register 3 at SA 0x00h

Address 0x03 CONTROL_3 Read/Write Default Value = 00h

Bit Number	7	6	5	4	3	2	1	0
Bit Name	res	res	res	res	res	res	res	CBAR
Default	Reserved							0

Bit	Mnemonic	Function
7:1	Reserved	Set to 0
0	CBAR	internal color bar generator (0 = off, 1 = on)

Control Register 4 at SA 0x00h

Address 0x04 CONTROL_4 Read/Write Default Value = 3Fh

Bit Number	7	6	5	4	3	2	1	0
Bit Name	res	res	COMDAC_PD	SVIDLUM_PD	SVIDCHR_PD	res	res	res
Default	Reserved		1	1	1	Reserved		

Bit	Mnemonic	Function
7:6	-	Reserved
5	COMDAC_PD	power down composite DAC 0: power up, 1: power down
4	SVIDLUM_PD	power down luma s-video DAC 0: power up, 1: power down
3	SVIDCHR_PD	power down chroma s-video DAC 0: power up, 1: power down
2:0	-	Reserved set to "111"

Control Register 5 at SA 0x00h

Address 0x05 CONTROL_5 Read/Write Default Value = 00h

Bit Number	7	6	5	4	3	2	1	0
Bit Name	RSVD	LOW_IMP	EN_COM	EN_L	EN_C	res	res	res

Default	0	0	0	0	0	Reserved
---------	---	---	---	---	---	----------

Bit	Mnemonic	Function
7	-	reserved
6	LOW_IMP	selects between high output impedance (0) or low output impedance (1) mode of DACs
5	EN_COM	enable DAC for composite output 0: tri-state, 1: enable
4	EN_L	enable s-video DAC for luma output 0: tri-state, 1: enable
3	EN_C	enable s-video DAC for chroma output 0: tri-state, 1: enable
2:0	-	Reserved set to 0

Control Register 6 at SA 0x00h

Address 0x06 CONTROL_6 Read/Write Default Value = 00h

Bit Number	7	6	5	4	3	2	1	0
Bit Name	res	CLIP_OFF	res	res	res	res	res	res
Default	0	0	0	0	0	0	0	0

Bit	Mnemonic	Function
7	res	set to 0
6	CLIP_OFF	Clipping input signals disable (0: clipping active 1: no clipping)
5:0	res	set to 0

Background Color Register at SA 0x00h

Address 0x08 BKG_COLOR Read/Write Default Value = 03h

Bit Number	7	6	5	4	3	2	1	0
Bit Name	BG							
Default	0	0	0	0	0	0	1	1

Bit	Mnemonic	Function
7:0	BG	Background color (7:5 = R, 4:2 = G, 1:0 = B) (default is 0000 0011 - blue)

GPIO Control Register at SA 0x00h

Address 0x09 GPIO_REG Read/Write Default Value = 00h

Bit Number	7	6	5	4	3	2	1	0
Bit Name	GPR_CNTRL							
Default	res	res	res	res	res	0	0	0

Bit	Mnemonic	Function
2:0	GPR_CNTRL	Input(0)/output(1) control of GPIO registers (bit 0: GPIO(0), bit 2: GPIO(2))

GPIO Data Register at SA 0x00h

Address 0x0A GPIO_REG Read/Write Default Value = 00h

Bit Number	7	6	5	4	3	2	1	0
Bit Name	GPIO_REG							
Default	res	res	res	res	res	0	0	0

Bit	Mnemonic	Function
2:0	GPIO_REG	GPIO data register (data is output on GPIO bus if appropriate bit in address 09 is set to "1", otherwise data is input/output through I ² C)- This register is only accessible in I ² C mode.

Sync Register 0 at SA 0x00h

Address 0x0D Sync_0 Read/Write Default Value = 90h

Bit Number	7	6	5	4	3	2	1	0
Bit Name	res	res	res	res	res	res	res	res
Default	1	0	0	1	0	0	0	0

Bit	Mnemonic	Function
7:0	Reserved	

Sync Register 1 at SA 0x00h

Address 0x0E Sync_1 Read/Write Default Value = F4h

Bit Number	7	6	5	4	3	2	1	0
Bit Name	res	res	res	res	res	res	res	res
Default	1	1	1	1	0	1	0	0

Bit	Mnemonic	Function
7:0	res	res

I²C Address Register of TV encoder at SA 0x00h

 Address 0x0F I²C_ADR Read/Write Default Value = 00h

Bit Number	7	6	5	4	3	2	1	0
Bit Name	RESERVED	I ² C_ADR						
Default	0	0	0	0	0	0	0	0

Bit	Mnemonic	Function
7	-	reserved
6:0	I ² C	I ² C device address (programmable) do not program to 34h

Subcarrier Amplitude Register at SA 0x00h

Address 0×10 SC_AMP Read/Write Default Value = 1Ch

Bit Number	7	6	5	4	3	2	1	0
Bit Name	BU_AMP							
Default	0	0	0	1	1	1	0	0

Bit	Mnemonic	Function
7:0	BU_AMP	Color burst amplitude

Subcarrier Synthesis Register at SA 0x00h

Address	0×11	SC_SYNTH0	Read/Write	Default Value = 3Eh
	0×12	SC_SYNTH1		F8h
	0×13	SC_SYNTH2		E0h
	0×14	SC_SYNTH3		43h

Register	Bits	Mnemonic	Function
SC_SYNTH0	7:0	CC_0	Subcarrier synthesis bits 7:0
SC_SYNTH1	7:0	CC_1	Subcarrier synthesis bits 15:8
SC_SYNTH2	7:0	CC_2	Subcarrier synthesis bits 23:16
SC_SYNTH3	7:0	CC_3	Subcarrier synthesis bits 31:24

Hue LSB Adjust Register at SA 0x00h

Address 0×15 HUE_LSB Read/Write Default Value = 00h

Bit Number	7	6	5	4	3	2	1	0
Bit Name	HUE LSB							
Default	0	0	0	0	0	0	0	0

Bit	Mnemonic	Function
7:0	HUE LSB	8 LSBs for hue phase shift

Hue MSB Adjust Register at SA 0x00h

Address 0×16 HUE_MSB Read/Write Default Value = 00h

Bit Number	7	6	5	4	3	2	1	0
Bit Name	RESERVED						MSB	
Default	0	0	0	0	0	0	0	0

Bit	Mnemonic	Function
7:2	-	reserved
1:0	HUE_MSB	2 MSBs for hue phase shift

SCH Sync Phase Adjust at SA 0x00h

Address 0x17 SCH Read/Write Default Value = 00h

Bit	Mnemonic	Function
7:0	SCH	Default - 00h in increments of ≈ 1.4 degree per bit up to 360°

Closed Caption Enable Register at SA 0x00h

Address 0x18 CC_EN Read/Write Default Value = 00h

Bit Number	7	6	5	4	3	2	1	0
Bit Name	RESERVED						EN_284	EN_21
Default	0	0	0	0	0	0	0	0

Bit	Mnemonic	Function
7:2	-	reserved
1	CC_EN[1]	enable closed caption for line 284
0	CC_EN[0]	enable closed caption for line 21

Closed Caption Data Register at SA 0x00h

 Address 0x19 CC_21_1 Read/Write Default Value = 00h
 0x1A CC_21_2 00h
 0x1B CC_284_1 00h
 0x1C CC_284_2 00h

Bit	Mnemonic	Function
7:0	CC_21_1	first closed caption databyte of line 21
7:0	CC_21_2	second closed caption databyte of line 21
7:0	CC_284_1	first closed caption databyte of line 284
7:0	CC_284_2	second closed caption databyte of line 284

Filter Register 0 at SA 0x00h

Address 0x22 CB_AMP Read/Write Default Value = 80h

Bit Number	7	6	5	4	3	2	1	0
Bit Name	U_AMP							
Default	1	0	0	0	0	0	0	0

Bit	Mnemonic	Function
7:0	U_AMP	U(Cb) amplitude coefficient

Filter Register 1 at SA 0x00h

Address 0x23 CR_AMP Read/Write Default Value = 80h

Bit Number	7	6	5	4	3	2	1	0
------------	----------	----------	----------	----------	----------	----------	----------	----------

Bit Name	V_AMP							
Default	1	0	0	0	0	0	0	0

Bit	Mnemonic	Function
7:0	V_AMP	V(Cr) amplitude coefficient

Filter Register 2 at SA 0x00h

Address 0x24 Y_AMP Read/Write Default Value = 80h

Bit Number	7	6	5	4	3	2	1	0
Bit Name	Y_AMP							
Default	1	0	0	0	0	0	0	0

Bit	Mnemonic	Function
7:0	Y_AMP	Luma amplitude coefficient

Filter Register 6 at SA 0x00h

Address 0x28 Bright_Offsett Read/Write Default Value = 00h

Bit Number	7	6	5	4	3	2	1	0
Bit Name	BRIGHTNESS_OFFSET							
Default	0	0	0	0	0	0	0	0

Bit	Mnemonic	Function
7:0	BRGHT_OFFSET	Brightness adjustment (range: -128 to +127)

Control Register of Color Space Processor Section: SA 0x34h

Address	Register Name	Type	Defaultvalue
[00]	Master reset	r/w	00h
[01]	Status	r only	00h
[02]	Pin i/o control	r/w	00h
[03]	Digital gain	r/w	08h
[04]	Scaler control	r/w	00h
[05]	Feature control	r/w	00h
[06]	Operation control 1	r/w	0Dh
[07]	Operation control 2	r/w	00h
[08]	Red balance	r/w	80h
[09]	Blue balance	r/w	80h
[0A]	Red saturation	r/w	80h
[0B]	Blue saturation	r/w	80h
[0C]	Gamma correction	r/w	01h
[0D]	Reserved		
[0E]	Reserved		
[0F]	Reserved		
[10]	YR coefficient	r/w	80h
[11]	CrR coefficient	r/w	7Ch
[12]	CbR coefficient	r/w	E0h
[13]	YG coefficient	r/w	80h
[14]	CrG coefficient	r/w	E4h
[15]	CbG coefficient	r/w	DCh
[16]	YB coefficient	r/w	80h
[17]	CrB coefficient	r/w	ECh
[18]	CbB coefficient	r/w	7Ch
[19]	Slave data hold	r/w	00h
[1A]	EEPROM count LSB	r/w	00h
[1B]	EEPROM count MSB	r/w	00h
[1C]	Version_major	r only	FDh
[1D]	Version_minor	r only	00h
[1E]	Reserved		
[1F]	Reserved		
[20]	Low power	r/w	00h
[21]	Reserved		
[22]	Reserved		
[23]	Anti-alias	r/w	00h
[24]	Reserved		
[25]	Reserved		
[26]	Reserved		
[27]	Flare control 1	r/w	00h
[28]	Flare control 2	r/w	00h
[29]	Flare control 3	r/w	00h
[2A]	Flare control 4	r/w	00h
[2B]	Flare control 5	r/w	00h

Table 14. DSP Control Register

Address	Register Name	Type	Defaultvalue
[2C]	Flare control 6	r/w	00h
[2D]	Scaler control 1	r/w	00h
[2E]	Scaler control 2	r/w	00h
[2F]	Scaler control 3	r/w	00h
[30]	Config 0	r/w	00h
[31]	Config 1	r/w	00h
[32]	Config 2	r/w	00h
[33]	Config 3	r/w	00h
[34]	Config 4	r/w	00h
[35]	Config 5	r/w	00h
[36]	Config 6	r/w	00h
[37]	Config 7	r/w	00h
[38]	Config 8	r/w	00h
[39]	Config 9	r/w	00h
[3A]	Config 10	r/w	00h
[3B]	Config 11	r/w	00h
[3C]	Config 12	r/w	00h
[3D]	Config 13	r/w	00h
[3E]	Config 14	r/w	00h
[3F]	Config 15	r/w	00h
[40]	Jump 0	r/w	00h
[41]	Jump 1	r/w	00h
[42]	EEPROM control	r/w	00h
[43]	Config index	r/w	00h
[44]	Reserved		
[FE]	Reserved		
[FF]	Station address	r/w	1Ah

Table 14. DSP Control Register (Continued)
Master Reset Register (00h at SA 0x34h)

7	6	5	4	3	2	1	0
res	res	res	res	res	res	res	MR
Reserved							W

MR Setting bit MR0 to logic high will initiate a CS7654 master reset equivalent to executing an external reset using the RESET pin. All registers will be placed in their default state, and the download of any external EPROM present on the secondary I²C bus will be initiated. The bit is self-cleared.

Status Register (01h at SA 0x34h)

7	6	5	4	3	2	1	0
res	P4BYTE	res	HIZENB	INITACT	I2CBUSY	NODEV	EVNFLD
Reserved	R	Reserved	R	R	R	R	R

EVNFLD Logic high indicates even field of interline-transfer CCD. Logic low indicates odd field of interline-transfer CCD. This bit provides a course means of synchronizing to the field rate.

NODEV Logic high indicates that the addressed slave device on the secondary I²C bus did not respond.

I2CBUSY	Logic high indicates that the CS7654 secondary I ² C master is busy accessing the addressed slave device.
INITACT	Logic high indicates the CS7654 master is busy initializing registers from the external I ² C EEPROM on the secondary I ² C bus (if present).
HIZENB	Pin 44 status.
P4BYTE	Pin 46 status.

PIN I/O Control (02h at SA 0x34h)

7	6	5	4	3	2	1	0
res	res	res	res	res	res	res	PLLOUT
Reserved					Reserved	Reserved	R/W

PLLOUT Logic high enables the PLL clock output to the CS7615 (pin 51).

Digital Gain Register (03h at SA 0x34h)

7	6	5	4	3	2	1	0
res	res	res	DG4	DG3	DG2	DG1	DG0
Reserved			R/W				

DG[0:4] Controls the digital gain applied to the SVID_Y (Luminance) signal after the RGB to YCrCb converter block. The range of gains are from 0 to 31/8 in increments of 1/8. A gain of 0, indicates no brightness.

Scaler Control (04h at SA 0x34h)

7	6	5	4	3	2	1	0
res	res	res	res	CUSTOM	MODE2	MODE1	MODE0
Reserved		Reserved	Reserved	R/W	R/W		

MODE[2:0] Selects 1 of 8 pre-defined scaling ratios.

CUSTOM When set, scaler uses custom values held in registers 2Dh-2Fh.

Feature Control Register (05h at SA 0x34h)

7	6	5	4	3	2	1	0
res	res	res	CHROFF	LUMOFF	GAMON	AWB	res
Reserved			R/W	R/W	R/W	R/W	Reserved

AWB The Automatic White Balance procedure is initiated by pointing to a white scene and setting this bit high. The bit will return a logic high while the AWB procedure is in progress. Setting this bit low will have no effect. This bit will always be read as a "0" when the AWB is not in progress.

GAMON The gamma correction from the gamma ram look up table is applied to the video signal in R-G-B space when this bit is set high. The gamma ram is a fully user programmable, 256 entry look up table.

LUMOFF Setting LUMOFF bit high disables the luma peaking filter.

CHROFF Setting the CHROFF bit high disables the chroma low-pass filter for minimizing color aliasing.

Operational Control Register (06h at SA 0x34h)

7	6	5	4	3	2	1	0
res	res	res	INREF	OE	POSPIX	EBLU	OBLU
Reserved	Reserved	Reserved	R/W	R/W	R/W	R/W	R/W

- OBLU** Logic high causes the first line after VREF of the odd field to be processed as a BLUE line. Logic low causes the first line of the odd field to be processed as a RED line.
- EBLU** Logic high causes the first line after VREF of the even field to be processed as a BLUE line. Logic low causes the first line of the even field to be processed as a RED line.
- POSPIX** Logic “1” causes the first pixel of the first line to be treated as a positive pixel in the color separation block. Logic “0” causes the first pixel to be treated as a negative pixel. Try toggling this bit if the colors appear “reversed.”
- OE** The Output Enable Bit operates in conjunction with the external $\overline{\text{HIZEN}}$ Pin, as illustrated in Table 15.

OE Bit	HIZEN Pin	Digital Outputs
0	0	High-Z
0	1	High-Z
1	0	High-Z
1	1	Enabled

Table 15. OE Pin and Bit Operation

- INREF** Logic “1” causes CS7654 to accept HREF input and VREF input pins as the reference inputs signals. EAV and SAV codes in the CCD data stream are ignored. Logic “0” causes the internal de-formatter to decode and follow the embedded EAV and SAV codes sent from the CCD digitizer (as with the CS7615).

Operational Control Register II (07h at SA 0x34h)

7	6	5	4	3	2	1	0
TEST_AA	CLIP_OFF	res	res	res	res	res	res
R/W	R/W	Reserved	Reserved	Reserved	Reserved	Reserved	Reserved

- CLIP_OFF** When set, excludes only 00 and FF from output data. Otherwise ITU BT 601 definition
- TEST_AA** This bit is reserved for test purposes and may be set as a 1 or a 0.

Red Balance Register (08h at SA 0x34h)

7	6	5	4	3	2	1	0
RB7	RB6	RB5	RB4	RB3	RB2	RB1	RB0
R/W							

- RB[7:0]** The Red Balance register controls the red contribution to the R-Y chrominance signal. When the register value is 00h, the red contribution is minimized; when the register value is FFh, the red contribution is maximized. When the AWB correction is in progress, this register value is adjusted such that the absolute magnitude of the R-Y signal is minimized.

Blue Balance Register (09h at SA 0x34h)

7	6	5	4	3	2	1	0
BB7	BB6	BB5	BB4	BB3	BB2	BB1	BB0
R/W							

BB[7:0] The Blue Balance register controls the blue contribution to the B-Y chrominance signal. When the register value is 00h, the blue contribution is minimized; when the register value is FFh, the blue contribution is maximized. When the AWB correction is in progress, this register value is adjusted such that the absolute magnitude of the B-Y signal is minimized.

Red Saturation Register (0Ah at SA 0x34h)

7	6	5	4	3	2	1	0
RS7	RS6	RS5	RS4	RS3	RS2	RS1	RS0
R/W							

RS[7:0] The Red Saturation register value controls the amplitude of the R-Y chrominance signal. When the register value is 00h, the amplitude of the R-Y is minimized; when the register value is FFh, the amplitude of the R-Y is maximized.

Blue Saturation Register (0Bh at SA 0x34h)

7	6	5	4	3	2	1	0
BS7	BS6	BS5	BS4	BS3	BS2	BS1	BS0
R/W							

BS[7:0] The Blue Saturation register value controls the amplitude of the B-Y chrominance signal. When the register value is 00h, the amplitude of the B-Y is minimized; when the register value is FFh, the amplitude of the B-Y is maximized.

Gamma Correction Register (0Ch at SA 0x34h)

Writing to the gamma register (0Ch at SA 0x34h) selects the R, G, and/or B RAM. Continuing data writes without sending a stop bit after the register write results in writes to the ram locations starting with 00h and continuing to FFh. Reads from register 0Ch function in a similar way. NOTE: All three gamma rams may be selected for simultaneous writes, but read should be done one ram table at a time.

7	6	5	4	3	2	1	0
GC7	GC6	GC5	GC4	GC3	GC2	GC1	GC0
R/W							

- GC0 Logic "1" selects BLUE gamma RAM for subsequent access.
- GC1 Logic "1" selects GREEN gamma RAM for subsequent ram access.
- GC2 Logic "1" selects RED gamma RAM for subsequent ram access.
- GC[0:7] Provide R/W access to RAM after gamma RAM table has been selected.

Test Control A Register (0Eh at SA 0x34h)

This register is reserved

Test Control B Register (0Fh at SA 0x34h)

This register is reserved.

YR Coefficient Register (10h at SA 0x34h)

7	6	5	4	3	2	1	0
YR7	YR6	YR5	YR4	YR3	YR2	YR1	YR0
R/W							

Color separation and color space conversion coefficient.

CrR Coefficient Register (11h at SA 0x34h)

7	6	5	4	3	2	1	0
CrR7	CrR6	CrR5	CrR4	CrR3	CrR2	CrR1	CrR0
R/W							

Color separation and color space conversion coefficient.

CbR Coefficient Register (12h at SA 0x34h)

7	6	5	4	3	2	1	0
CbR7	CbR6	CbR5	CbR4	CbR3	CbR2	CbR1	CbR0
R/W							

Color separation and color space conversion coefficient.

YG Coefficient Register (13h at SA 0x34h)

7	6	5	4	3	2	1	0
YG7	YG6	YG5	YG4	YG3	YG2	YG1	YG0
R/W							

Color separation and color space conversion coefficient.

CrG Coefficient Register (14h at SA 0x34h)

7	6	5	4	3	2	1	0
CrG7	CrG6	CrG5	CrG4	CrG3	CrG2	CrG1	CrG0
R/W							

Color separation and color space conversion coefficient.

CbG Coefficient Register (15h at SA 0x34h)

7	6	5	4	3	2	1	0
CbG7	CbG6	CbG5	CbG4	CbG3	CbG2	CbG1	CbG0
R/W							

Color separation and color space conversion coefficient.

YB Coefficient Register (16h at SA 0x34h)

7	6	5	4	3	2	1	0
YB7	YB6	YB5	YB4	YB3	YB2	YB1	YB0
R/W							

Color separation and color space conversion coefficient.

CrB Coefficient Register (17h at SA 0x34h)

7	6	5	4	3	2	1	0
CrB7	CrB6	CrB5	CrB4	CrB3	CrB2	CrB1	CrB0
R/W							

Color separation and color space conversion coefficient.

CbB Coefficient Register (18h at SA 0x34h)

7	6	5	4	3	2	1	0
CbB7	CbB6	CbB5	CbB4	CbB3	CbB2	CbB1	CbB0
R/W							

Color separation and color space conversion coefficient.

Slave Data Hold Register (19h at SA 0x34h)

When an external I²C controller initiates a register read from a slave device on the secondary I²C bus through CS7654, the returned data is placed in this register. The external controller may then read the data from the Slave Data Hold register. This register is read only.

EPROM Count Low Byte Register (1Ah at SA 0x34h)

Lower byte of the number of triple-bytes to be read from EPROM upon reset of CS7654. This register is read only.

EPROM Count High Byte Register (1Bh at SA 0x34h)

Upper byte of the number of triple-bytes to be read from EPROM upon reset of CS7654. This register is read only.

Version (Major) Register (1Ch at SA 0x34h)

The major version register (device ID) in the CS7654 is assigned the value FDh. This register is read only.

Version (Minor) Register (1Dh at SA 0x34h)

The minor version register in CS7654 rev A. is assigned the value 00h. With each minor revision the value is increased by 1. This register is read only.

Low Power Register (20h at SA 0x34h)

7	6	5	4	3	2	1	0
res	res	res	res	res	res	res	PD
Reserved							R/W

PD Setting bit PD to “1” will place the CS7654 in low power mode.

Test Enable Register (21h at SA 0x34h)

This register is reserved.

Reserved Register (22h at SA 0x34h)

This register is reserved and returns a valud of 00 when read.

Anti-Alias (23h at SA 0x34h)

This register is reserved and must be set to 08h for normal operation.

Test_AA2 (24h at SA 0x34h)

This register is reserved and must be set to FFh for normal operation

Test_AA3 (25h at SA 0x34h)

This register is reserved and must be set to FFh for normal operation

Test_AA4 (26h at SA 0x34h)

This register is reserved and must be set to FFh for normal operation

Flare Control 1 (27h at SA 0x34h)

7	6	5	4	3	2	1	0
Y_THR9	Y_THR8	Y_THR7	Y_THR6	Y_THR5	Y_THR4	Y_THR3	Y_THR2
R/W							

Y_THR[9:2] Flare control filter Y threshold bits 9-2 (MSB). (Bits 1 and 0 set to 0.)

Flare Control 2 (28h at SA 0x34h)

7	6	5	4	3	2	1	0
Cr_L9	Cr_L8	Cr_L7	Cr_L6	Cr_L5	Cr_L4	Cr_L3	Cr_L2
R/W							

Cr_L[9:2] Flare control filter Cr low threshold bits 9-2 (MSB).

Flare Control 3 (29h at SA 0x34h)

7	6	5	4	3	2	1	0
Cb_L9	Cb_L8	Cb_L7	Cb_L6	Cb_L5	Cb_L4	Cb_L3	Cb_L2
R/W							

Cb_L[9:2] Flare control filter Cb low threshold bits 9-2 (MSB). (Bits 1 and 0 set to 0.)

Flare Control 4 (2Ah at SA 0x34h)

7	6	5	4	3	2	1	0
Cr_H9	Cr_H	Cr_H7	Cr_H6	Cr_H5	Cr_H4	Cr_H3	Cr_H2
R/W							

Cr_H[9:2] Flare control filter Cr high threshold bits 9-2 (MSB).

Flare Control 5 (2Bh at SA 0x34h)

7	6	5	4	3	2	1	0
Cb_H9	Cb_H8	Cb_H7	Cb_H6	Cb_H5	Cb_H4	Cb_H3	Cb_H2
R/W							

Cb_H[9:2] Flare control filter Cb high threshold bits 9-2 (MSB). (Bits 1 and 0 set to 0.)

Flare Control 6 (2Ch at SA 0x34h)

7	6	5	4	3	2	1	0
Cb_H1	Cb_H0	Cr_H1	Cr_H0	Cb_L1	Cb_L0	Cr_L1	Cr_L0
R/W		R/W		R/W		R/W	

Cr_L[1:0] Flare control filter Cr low threshold bits 1 and 0.

Cb_L[1:0] Flare control filter Cb low threshold bits 1 and 0.

Cr_H[1:0] Flare control filter Cr high threshold bits 1 and 0.

Cb_H[1:0] Flare control filter Cb high threshold bits 1 and 0.

Scaler Control 1 (2Dh at SA 0x34h)

7	6	5	4	3	2	1	0
BYPASS1	BYPASS0	res	PLL_M4	PLL_M3	PLL_M2	PLL_M1	PLL_M0
R/W		Reserved	R/W				

PLL_M[4:0] This is the PLL M value when the CUSTOM bit (bit 3 register 04h) is set.

BYPASS[1:0] See PLL section.

Scaler Control 2 (2Eh at SA 0x34h)

7	6	5	4	3	2	1	0
HALF	res	res	PLL_N4	PLL_N3	PLL_N2	PLL_N1	PLL_N0
R/W	Reserved		R/W				

PLL_N[4:0] This is the PLL N value when the CUSTOM bit (bit 3 register 04h at SA 0x34h) is set.

HALF Sets the internal PLL reference clock to 1/2 the input clock.

Scaler Control 3 (2Fh at SA 0x34h)

7	6	5	4	3	2	1	0
OFFSET7	OFFSET6	OFFSET5	OFFSET4	OFFSET3	OFFSET2	OFFSET1	OFFSET0
R/W							

OFFSET[7:0] This value controls the offset to the internal Scaler.

Configuration Control 0 (30h at SA 0x34h)

7	6	5	4	3	2	1	0
res	res	res	res	res	SKP010	SKP09	SKP08
Reserved					R/W		

This register contains the 3 MSBs of the EEPROM address used when the SKIP bit is set (bit1 register 42h at SA 0x34h) and the Configuration Index Register (43h at SA 0x34h) is set to 00h.

Configuration Control 1 (31h at SA 0x34h)

7	6	5	4	3	2	1	0
SKP07	SKP06	SKP05	SKP04	SKP03	SKP02	SKP01	SKP00
R/W							

This register contains the 8 LSBs of the EEPROM start address used when the SKIP bit is set (bit1 register 42h at SA 0x34h) and the Configuration Index Register (43h at SA 0x34h) is set to 00h.

Configuration Control 2 (32h at SA 0x34h)

7	6	5	4	3	2	1	0
res	res	res	res	res	SKP110	SKP19	SKP18
Reserved					R/W		

This register contains the 3 MSBs of the EEPROM address used when the SKIP bit is set (bit1 register 42h at SA 0x34h) and the Configuration Index Register (43h at SA 0x34h) is set to 01h.

Configuration Control 3 (33h at SA 0x34h)

7	6	5	4	3	2	1	0
SKP17	SKP16	SKP15	SKP14	SKP13	SKP12	SKP11	SKP10
R/W							

This register contains the 8 LSBs of the EEPROM start address used when the SKIP bit is set (bit1 register 42h at SA 0x34h) and the Configuration Index Register (43h at SA 0x34h) is set to 01h.

Configuration Control 4 (34h at SA 0x34h)

7	6	5	4	3	2	1	0
res	res	res	res	res	SKP210	SKP29	SKP28
Reserved					R/W		

This register contains the 3 MSBs of the EEPROM address used when the SKIP bit is set (bit1 register 42h at SA 0x34h) and the Configuration Index Register (43h at SA 0x34h) is set to 02h.

Configuration Control 5 (35h at SA 0x34h)

7	6	5	4	3	2	1	0
SKP27	SKP26	SKP25	SKP24	SKP23	SKP22	SKP21	SKP20
R/W							

This register contains the 8 LSBs of the EEPROM start address used when the SKIP bit is set (bit1 register 42h at SA 0x34h) and the Configuration Index Register (43h at SA 0x34h) is set to 02h.

Configuration Control 6 (36h at SA 0x34h)

7	6	5	4	3	2	1	0
res	res	res	res	res	SKP310	SKP39	SKP38
Reserved					R/W		

This register contains the 3 MSBs of the EEPROM address used when the SKIP bit is set (bit1 register 42h at SA 0x34h) and the Configuration Index Register (43h at SA 0x34h) is set to 03h.

Configuration Control 7 (37h at SA 0x34h)

7	6	5	4	3	2	1	0
SKP37	SKP36	SKP35	SKP34	SKP33	SKP32	SKP31	SKP30
R/W							

This register contains the 8 LSBs of the EEPROM start address used when the SKIP bit is set (bit1 register 42h at SA 0x34h) and the Configuration Index Register (43h at SA 0x34h) is set to 03h.

Configuration Control 8 (38h at SA 0x34h)

7	6	5	4	3	2	1	0
res	res	res	res	res	SKP410	SKP49	SKP48
Reserved					R/W		

This register contains the 3 MSBs of the EEPROM address used when the SKIP bit is set (bit1 register 42h at SA 0x34h) and the Configuration Index Register (43h at SA 0x34h) is set to 04h.

Configuration Control 9 (39h at SA 0x34h)

7	6	5	4	3	2	1	0
SKP47	SKP46	SKP45	SKP44	SKP43	SKP42	SKP41	SKP40
R/W							

This register contains the 8 LSBs of the EEPROM start address used when the SKIP bit is set (bit 1 register 42h at SA 0x34h) and the Configuration Index Register (43h at SA 0x34h) is set to 04h.

Configuration Control 10 (3Ah at SA 0x34h)

7	6	5	4	3	2	1	0
res	res	res	res	res	SKP510	SKP59	SKP58
Reserved					R/W		

This register contains the 3 MSBs of the EEPROM address used when the SKIP bit is set (bit 1 register 42h at SA 0x34h) and the Configuration Index Register (43h at SA 0x34h) is set to 05h.

Configuration Control 11 (3Bh at SA 0x34h)

7	6	5	4	3	2	1	0
SKP57	SKP56	SKP55	SKP54	SKP53	SKP52	SKP51	SKP50
R/W							

This register contains the 8 LSBs of the EEPROM start address used when the SKIP bit is set (bit 1 register 42h at SA 0x34h) and the Configuration Index Register (43h at SA 0x34h) is set to 05h.

Configuration Control 12 (3Ch at SA 0x34h)

7	6	5	4	3	2	1	0
res	res	res	res	res	SKP610	SKP69	SKP68
Reserved					R/W		

This register contains the 3 MSBs of the EEPROM address used when the SKIP bit is set (bit 1 register 42h at SA 0x34h) and the Configuration Index Register (43h at SA 0x34h) is set to 06h.

Configuration Control 13 (3Dh at SA 0x34h)

7	6	5	4	3	2	1	0
SKP67	SKP66	SKP65	SKP64	SKP63	SKP62	SKP61	SKP60
R/W							

This register contains the 8 LSBs of the EEPROM start address used when the SKIP bit is set (bit 1 register 42h at SA 0x34h) and the Configuration Index Register (43h at SA 0x34h) is set to 06h.

Configuration Control 14 (3Eh at SA 0x34h)

7	6	5	4	3	2	1	0
res	res	res	res	res	SKP710	SKP79	SKP78
Reserved					R/W		

This register contains the 3 MSBs of the EEPROM address used when the SKIP bit is set (bit 1 register 42h at SA 0x34h) and the Configuration Index Register (43h at SA 0x34h) is set to 07h.

Configuration Control 15 (3Fh at SA 0x34h)

7	6	5	4	3	2	1	0
SKP77	SKP76	SKP75	SKP74	SKP73	SKP72	SKP71	SKP70
R/W							

This register contains the 8 LSBs of the EEPROM start address used when the SKIP bit is set (bit 1 register 42h at SA 0x34h) and the Configuration Index Register (43h at SA 0x34h) is set to 07h.

Jump Control 0 (40h at SA 0x34h)

7	6	5	4	3	2	1	0
res	res	res	res	res	JMP10	JMP9	JPM8
Reserved					R/W		

This register contains the 3 MSBs of the EEPROM address used when the JUMP bit is set (bit 2 register 42h at SA 0x34h).

Jump Control 1 (41h at SA 0x34h)

7	6	5	4	3	2	1	0
JMP7	JMP6	JMP5	JMP4	JMP3	JMP2	JMP1	JPM0
R/W							

This register contains the 8 LSBs of the EEPROM start address used when the JUMP bit is set (bit 2 register 42h at SA 0x34h).

EEPROM Control (42h at SA 0x34h)

7	6	5	4	3	2	1	0
res	res	res	res	res	JUMP	SKIP	HALT
R/W							

State machine commands for loading EEPROM data after reset. (see extended EPROM configuration)

- HALT Writing a 1 to this bit stops the reading of EEPROM data.
- SKIP Writing a 1 to this bit forces the next EEPROM read cycle to occur at the address held in the Configuration Control (n) register, where "n" is the value held in the Configuration Index Register (43h at SA 0x34h)
- JUMP Writing a 1 to this bit forces the next EEPROM access to occur at the address held in registers 40h and 41h at SA 0x34h .

Configuration Index Register (43h at SA 0x34h)

7	6	5	4	3	2	1	0
res	res	res	res	res	SW2	SW1	SW0
Reserved						R/W	

This contains the DIP switch status at reset. (see extended EPROM configuration) The value of this register selects the appropriate Configuration register when the SKIP command is executed.

Reserved Registers (44h - FEh at SA 0x34h)

These registers are reserved and return a value of 00h when read.

Station Address Register (FFh at SA 0x34h)

7	6	5	4	3	2	1	0
res	SA6	SA5	SA4	SA3	SA2	SA1	SA0
Reserved	R/W						

CS7654 station address of the color processor, 7 MSBs (the LSB of the complete 8-bit station address is determined by the LSB which acts as a read/write direction bit).

BOARD DESIGN AND LAYOUT CONSIDERATIONS

The printed circuit layout should be optimized for lowest noise on the CS7654 placed as close to the output connectors as possible. All analog supply traces should be as short as possible to minimize inductive ringing.

A well designed power distribution network is essential in eliminating digital switching noise. The ground planes must provide a low-impedance return path for the digital circuits. A PC board with a minimum of four layers is recommended. The ground layer should be used as a shield to isolate noise from the analog traces. The top layer (1) should be reserved for analog traces but digital traces can share this layer if the digital signals have low edge rates and switch little current or if they are separated from the analog traces by a significant distance (dependent on their frequency content and current). The second layer should then be the ground plane followed by the analog power plane on layer three and the digital signal layer on layer four.

Power and Ground Planes

The power and ground planes need isolation gaps of at least 0.05" to minimize digital switching noise effects on the analog signals and components. A split analog/digital ground plane should be connected at one point as close as possible to the CS7654.

Power Supply Decoupling

Start by reducing power supply ripple and wiring harness inductance by placing a large (33-100 μ F) capacitor as close to the power entry point as possible. Use separate power planes or traces for the digital and analog sections even if they use the same supply. If necessary, further isolate the digital and analog power supplies by using ferrite beads on each supply branch followed by a low ESR capacitor.

Place all decoupling caps as close as possible to the device as possible. Surface mount capacitors generally have lower inductance than radial lead or axial lead components. Surface mount caps should be placed on the component side of the PCB to minimize inductance caused by board vias. Any vias, especially to ground, should be as large as possible to reduce their inductive effects.

Digital Interconnect

The digital inputs and outputs of the CS7654 should be isolated from the analog outputs as much as possible. Use separate signal layers whenever possible and do not route digital signals over the analog power and ground planes.

Noise from the digital section is related to the digital edge rates used. Ringing, overshoot, undershoot, and ground bounce are all related to edge rate. Use lower speed logic such as HCMOS for the host port interface to reduce switching noise. For the video input ports, higher speed logic is required, but use the slowest practical edge rate to reduce noise. To reduce noise, it is important to match the source impedance, line impedance, and load impedance as much as possible. Generally, if the line length is greater than one fourth the signal edge rate, line termination is necessary. Ringing can also be reduced by damping the line with a series resistor (22-150 Ω). Under extreme cases, it may be advisable to use microstrip techniques to further reduce radiated switching noise if very fast edge rates (<2 ns) are used. If microstrip techniques are used, split the analog and digital ground planes and use proper RF decoupling techniques.

Analog Interconnect

The CS7654 should be located as close as possible to the output connectors to minimize noise pickup and reflections due to impedance mismatch. All unused analog outputs should be placed in shutdown. This reduces the total power that the CS7654 requires, and eliminates the impedance mismatch presented

by an unused connector. The analog outputs should not overlay the analog power plane to maximize high frequency power supply rejection.

Analog Output Protection

To minimize the possibility of damage to the analog output sections, make sure that all video connectors are well grounded. The connector should have a good DC ground path to the analog and digital power supply grounds. If no DC (and low frequency) path is present, improperly grounded equipment can impose damaging reverse currents on the video out lines. Therefore, it is also a good idea to use output filters that are AC coupled to avoid any problems.

ESD and Latch up Protection

All MOS devices are sensitive to Electro Static Discharge (ESD). When manipulating these devices, proper ESD precautions are recommended to avoid performance degradation or permanent damage.

To prevent latch up, make sure that the analog ground and the digital ground are at the same potential, it also apply to the analog supply and the digital supply, they must be at the same potential.

At power up, make sure that the analog and digital supply are settled to their nominal voltage before applying any signal pin.

To further prevent from external voltage anomalies a 3.3 V zener diode should be applied. The diode should be located after the filter, close to the connector. Anode connected to ground and cathode connected to the video output pin.

External DAC Output Filter

If an output filter is required, the low pass filter shown in Figure 19 can be used.

Schematic & Layout Review Service

Confirm Optimum
Schematic & Layout
Before Building Your Board.

For Our Free Review Service
Call Applications Engineering.

C a l l : (5 1 2) 4 4 5 - 7 2 2 2

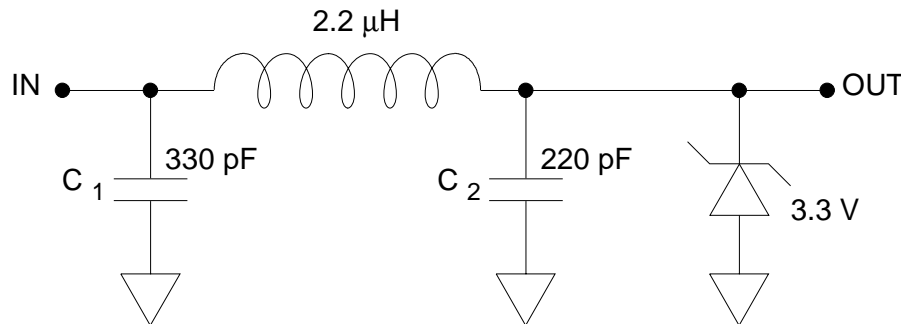
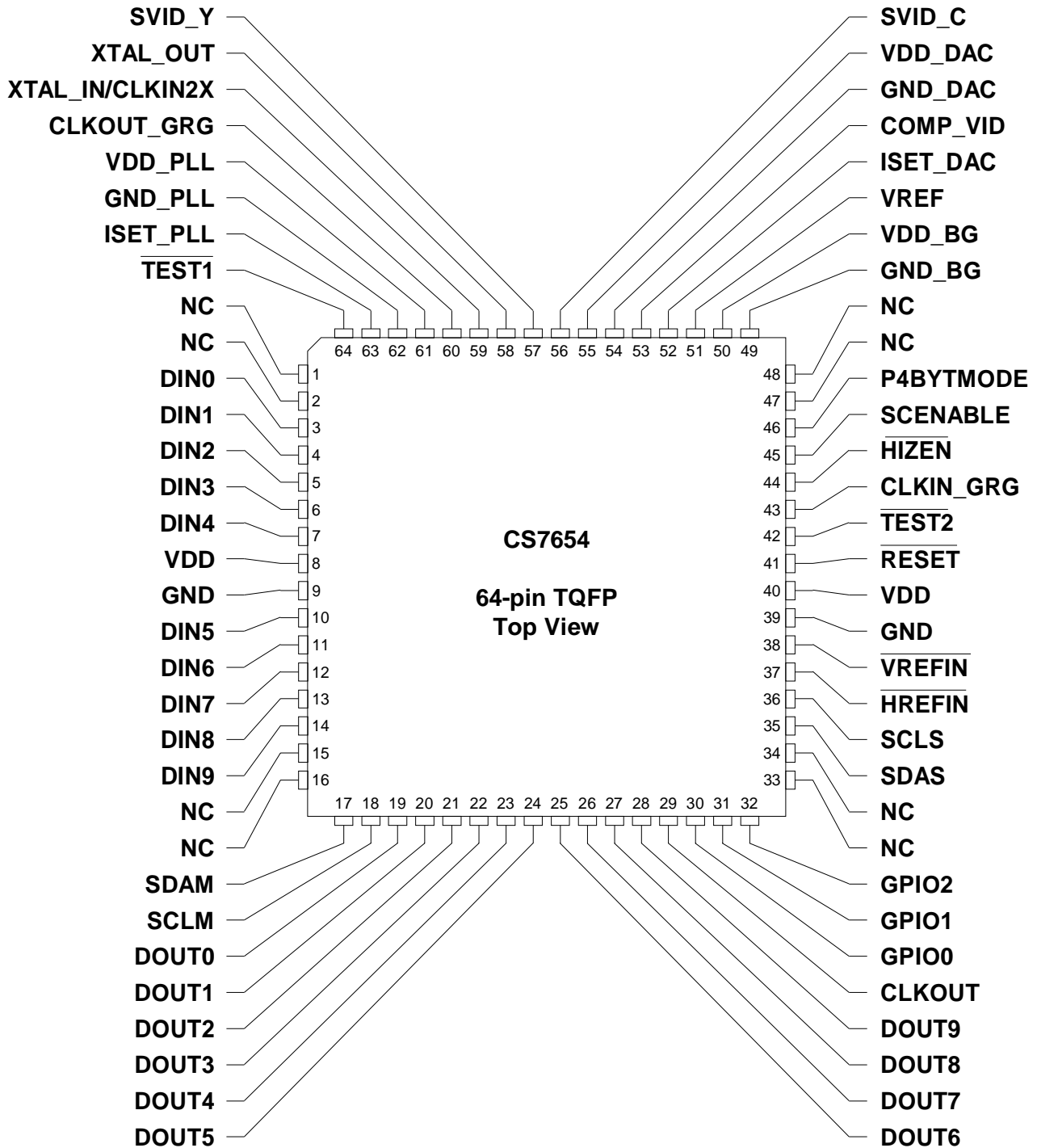


Figure 19. External Low Pass Filter
 C_2 should be chosen so that $C_1 = C_2 + C_{cable}$

PIN DESCRIPTIONS



Power Supply Connection

VDD - Power Supply, PINS 8, 40.

Positive digital supplies. Nominally +5 volts.

VDD_BG, VDD_DAC, VDD_PLL - Power Supply, PINS 50, 55, 61.

Positive analog supplies. Nominally +5 volts. Respectively Bandgap, DAC and PLL supplies.

GND - Digital Ground, PINS 9, 39.

Digital ground supplies.

GND_BG, GND_DAC, GND_PLL - Digital Ground, PINS 49, 54, 62.

Digital ground supplies. Respectively Bandgap, DAC and PLL ground.

Input Data and Clocks

DIN[9:0] - Digital Mosaic Inputs, Pins [15:10, 7:3].

CMOS level mosaic coded CCD input data from CCD digitizer

CLKIN_GRG - Mosaic Input Data Clock, PIN 43.

Main system input clock, used to strobe incoming digital CCD mosaic data. The CLKIN frequency is identical to the mosaic input data rate.

XTAL_IN/CLKIN2X - Mosaic Input Data Interpolation Clock, PIN 59.

Mosaic input data interpolation clock or crystal oscillator input.

CLKOUT_GRG - CCD Sample Clock, PIN 60.

This clock is scaled by the internal PLL and is equal to the CLKIN2X frequency divided by the scaling ratio. This clock is intended to connect to the CS7615 master clock pin (pin 32).

XTAL_OUT – Crystal oscillator output, PIN 58.

When using the internal crystal oscillator, connect the external crystal to the XTAL_OUT and CLKIN2X pins. If unused leave floating.

HREFIN - Horizontal Input Timing Reference, PIN 37.

Active low horizontal input timing reference. Used to synchronize the output timing signals with the incoming mosaic data and timing. When used with CCD digitizers like the CS7615 which imbed the necessary timing signals in the data stream, the HREFIN signal is not needed.

VREFIN - Vertical Input Timing Reference, PIN 38.

Active low vertical input timing reference. Used to synchronize the output timing signals with the incoming mosaic data and timing. When used with CCD digitizers like the CS7615 which embed the necessary timing signals in the data stream, the VREFIN signal is not needed.

I²C Serial Control

SDAS - Primary I²C Data Bus, PIN 35.

Primary I²C data bus. Used with SCL to read and write the internal register set.

SCLS - Primary I²C Clock, PIN 36.

Primary I²C Clock. Used with SDA to read and write the internal register set.

SDAM - Secondary I²C Data Bus, PIN 17.

Secondary I²C data bus with limited bus mastering capabilities. Used with SCLSEC to read and write I²C devices located on the secondary bus. Various devices can be isolated by the CS7654 from the primary I²C bus. The CS7654 will start reading I²C EPROM devices at addresses A0h after $\overline{\text{RESET}}$. It will download the EPROM contents into the specified registers inside the secondary bus devices as well as any CS7654 registers specified in the EPROM entries. Devices are typically connected to either the primary or the secondary I²C bus. However, the two busses may be connected together when system design requires the use of EPROM initialization while at the same allowing direct access to all the camera devices from the external I²C controller.

SCLM - Secondary I²C Clock, PIN 18.

Secondary I²C clock with limited bus mastering capabilities. Used with SDASEC to read and write I²C devices located on the secondary bus. Various devices can be isolated by the CS7654 from the primary I²C bus. The CS7654 will start reading I²C EPROM devices at addresses A0h after $\overline{\text{RESET}}$, and download the EPROM contents into the specified secondary bus registers, as well as any CS7654 registers specified in the EPROM entries. Devices are typically connected to either the primary or the secondary I²C bus. However, the two busses may be connected together when system design requires the use of EPROM initialization while at the same time allowing direct access to all the camera devices from the external I²C controller.

P4BYTMODE - Four-byte Mode I²C Operation Enable, PIN 46.

Places CS7654 in the Four-byte mode for I²C transactions on the primary I²C bus. Active high.

Digital Video Outputs and Clocking

DOUT[9:0] - Channel Digital Output Bits, Pins [28:19].

CMOS level 10-bit digital video output channel "A." Either YCrCb interleaved digital video output data, or Y component digital video data is available at this port according to the state of bit 5 in register 06h at SA 0x34h.

 $\overline{\text{HIZEN}}$ - Output enable, PIN 44.

CMOS level digital input pin to place all digital video output in HI-Z mode. This pin works in conjunction with OE bit in register 06h at SA 0x34h. To disable/power down DAC see registers description 0x04h and 0x05h at SA 0x00h.

CLKOUT - Digital Output Data Clock, PIN 29.

Digital output clock. Output data transitions on the falling edge of CLKOUT and can be latched on the rising edge. The CLKOUT rate is equal to twice the input mosaic pixel rate multiplied by the current scaling ratio with Y and CrCb output data available on DOUT [9:0].

*Analog***VREF - External voltage reference, PIN 51.**

Input to an external voltage reference of 1.235V. Leave floating if unused.

ISET_DAC - DAC bias, PIN 52.

Connect this pin to analog ground (AGND) through a 4K00 Ohms 1% resistor.

ISET_PLL - PLL bias, PIN 63.

Connect this pin to analog ground (AGND) through a 6K00 Ohms 1% resistor.

SVID_Y - S-Video output, LUMA , PIN 57.

Current DAC output, must have a doubly terminated load of 75R0 Ohms 1% resistor.

SVID_C - S-Video output, CHROMA , PIN 56.

Current DAC output, must have a doubly terminated load of 75R0 Ohms 1% resistor.

COMP_VID - Composite video output, PIN 53.

Current DAC output, must have a doubly terminated load of 75R0 Ohms 1% resistor.

*Miscellaneous***RESET - Master External Reset Control, PIN 41.**

CMOS input which initiates a complete power-on reset, where all registers are reset to their defaults, and the secondary I²C bus attempts to load any EPROM configuration information. This pin operates in conjunction with bit 0 of register 00h. RESET is an active logic low input.

TEST2 - Test Pin, PIN 42.

Test pin, connect to DGND.

TEST1 - Test Pin, PIN 64.

Test pin, connect to DGND.

SCENABLE - Test Pin, PIN 45.

Test pin, connect to GND.

GPIO[2..0]- General Purpose I/O port, PIN [32:30].

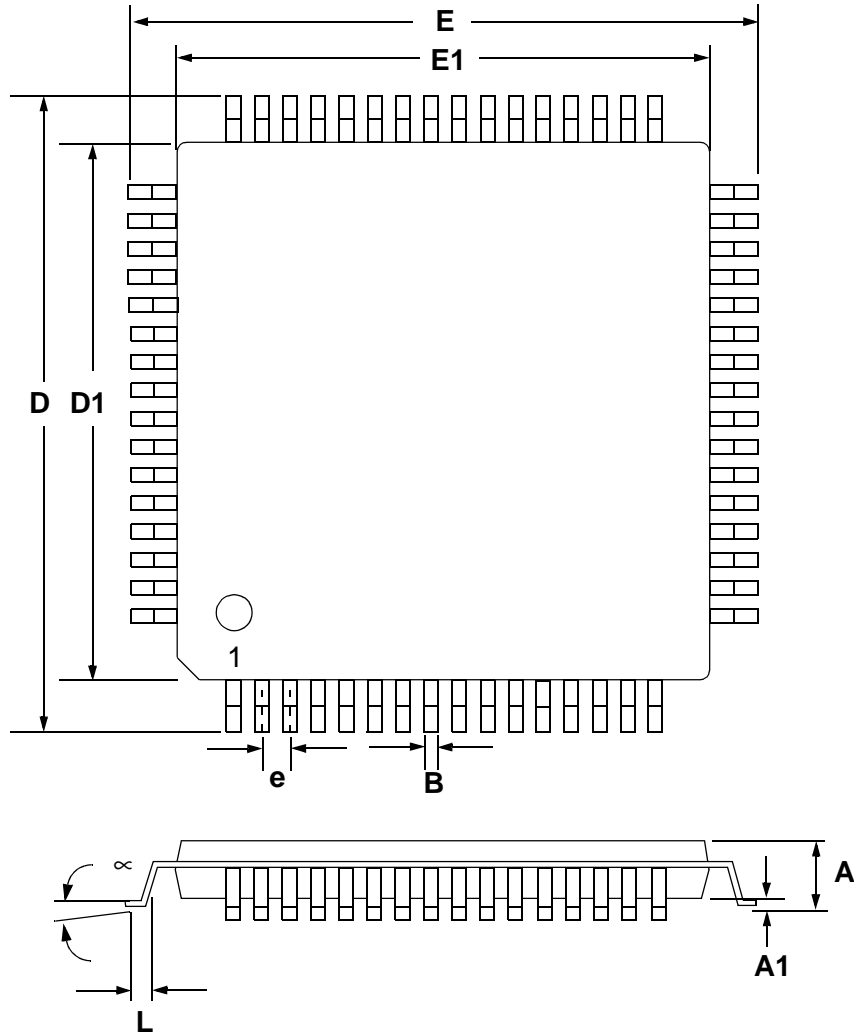
CMOS I/O. Also use by EPROM for configuration.

NC - No connect, PIN 1, 2, 15, 16, 33, 34, 47, 48.

No connect, leave floating.

PACKAGE DIMENSIONS

64L TQFP PACKAGE DRAWING



DIM	INCHES		MILLIMETERS	
	MIN	MAX	MIN	MAX
A	0.000	0.063	0.00	1.60
A1	0.002	0.006	0.05	0.15
B	0.007	0.011	0.17	0.27
D	0.461	0.484	11.70	12.30
D1	0.390	0.398	9.90	10.10
E	0.461	0.484	11.70	12.30
E1	0.390	0.398	9.90	10.10
e	0.016	0.024	0.40	0.60
L	0.018	0.030	0.45	0.75
∞	0.000	7.000	0.00	7.00

• **Notes** •

SMART
Analog™