

FEATURES

- 100 - 1000 MHz
- 7 mA, +5 VDC
- 1 dB LSB, 31 dB Range
- TTL Control
- 24 Pin Surface Mount Package



MODEL NO.
DA0760

PIN Diode 5 Section Attenuator

5 BIT

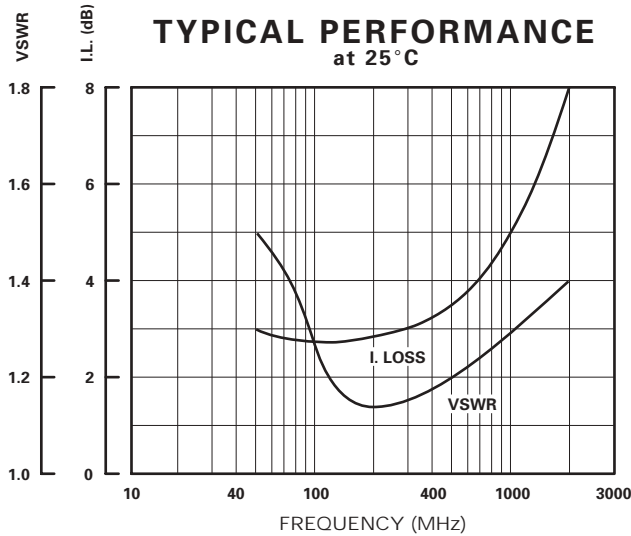
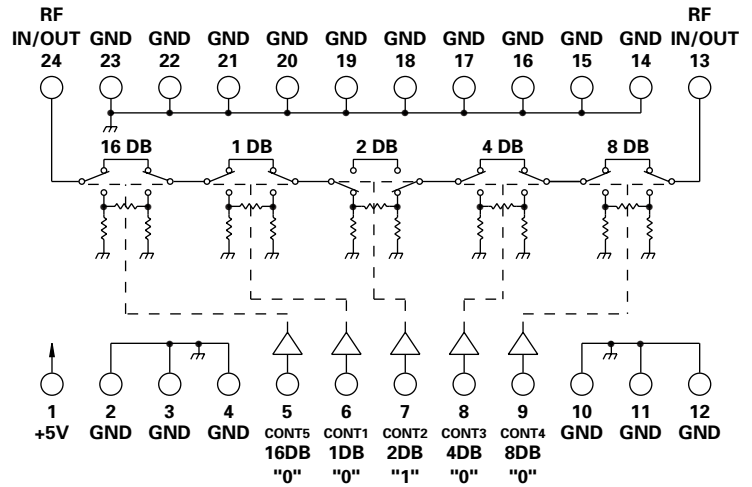
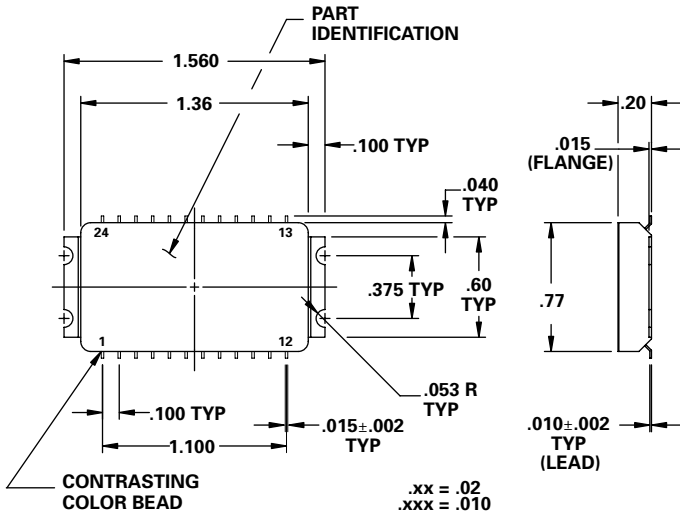

GUARANTEED PERFORMANCE

Parameter	Min	Typ	Max	Units	Conditions	
Operating Frequency	100		1000	MHz		
DC Current		7	20	mA	At +5 VDC Supply	
Control Current	High	1.0	±10	µA	VIH = +2.7 V	
	Low	1.0	±10	µA	VIL = +0.5 V	
Insertion Loss		4.0	5.0	dB	100 - 500 MHz	
			5.0	6.0	dB	500 - 1000 MHz
Attenuation	LSB		1	dB		
	Range	0		31	dB	1, 2, 4, 8, 16 dB
	Accuracy				dB	± (0.25 dB ± 3% of Atten. Setting in dB)
VSWR		1.3/1	1.5/1			
Impedance		50		OHMS		
Switching Speed		2	3	µSec	50% TTL to 90% / 10% RF	
Transition (Rise/Fall) Time		250	500	nSec	90% / 10% or 10% / 90% RF	
Switching (Video) Transients		100	500	mV	Peak Value	
Intercept Points	2nd	+60		dBm	400 MHz / 190 MHz	
	3rd	+33		dBm	300 MHz / 390 MHz	
RF Power	Operate	+13	+10	dBm	0.1 dB Compression	
	No Damage		+27	dBm		
Operating Temperature	-55	+25	+125	°C	TA	