

Ultra-Low Power LRA Haptic Driver with Multiple Input Triggers and Software-Free Operation

General Description

DA7283 is a linear resonant actuator (LRA) haptic driver offering automatic closed-loop LRA resonant frequency tracking. The feature guarantees consistency across LRA production tolerances, operating temperature, aging, and mechanical coupling. DA7283 does not require any programming to drive LRA motors within its supported range and will automatically lock to the correct LRA resonant frequency without any actuator information being provided to the device.

The differential output drive architecture and continuous actuator motion sensing enable efficient playback. Featuring three low-latency (0.75 ms) wake-up on general purpose input (GPI) sequence triggers, DA7283 automatically returns to a low quiescent current state (typically 0.68 μA) between playbacks. In OFF mode the device consumes only 5 nA, making it the appropriate choice for low power and long standby applications.

Three different types of haptic feedback effects can be triggered via the GPIs. Time domain control of these GPIs allows complex haptic effects playback capability at two different drive levels without the need for another digital interface to the device. This feature makes DA7283 perfectly suited for products that require unconditional haptic feedback like security applications or industrial products and small software footprint solutions like wearables or home automation.

Key Features

- LRA drive capability
- No device programming required
- Three GPI pins for triggering clicks and complex patterns at two drive levels
- Automatic LRA resonant frequency tracking
- Ultra-low power consumption, $I_Q = 5 \text{ nA}$, when the device is disabled
- Low latency (0.75 ms) GPI wake-up from low power consumption IDLE state, $I_Q = 0.68 \mu\text{A}$
- Differential PWM output drive
- Edge rate control for EMI suppression
- Current driven system to deliver constant actuator power
- Automatic short circuit protection
- Automatic over-temperature protection
- Automatic under-voltage lockout protection
- Automatic haptic playback timeout in case of host disappearance
- Supply monitoring and automatic output limiting
- Small solution footprint requiring only one decoupling capacitor in both WLCSP and QFN

Applications

- Security sensitive applications
- Smartphones, wearables, and hearables
- Computer peripherals
- Gaming
- Automotive and industrial
- Virtual and augmented reality controllers
- Disposable consumer products
- Toys
- TV remote controllers

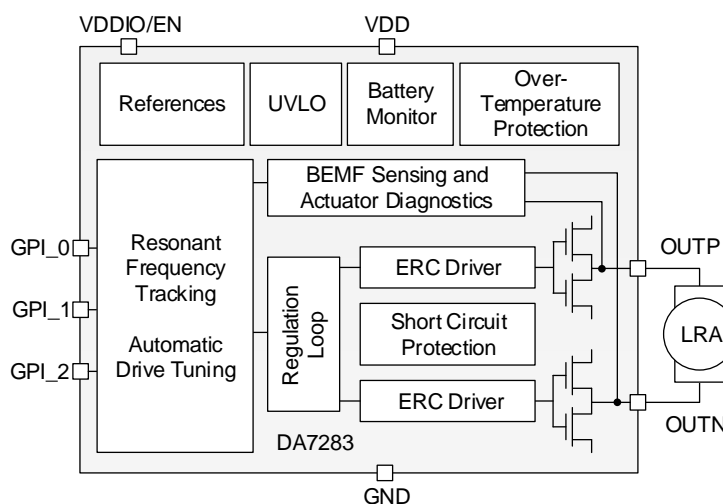

Ultra-Low Power LRA Haptic Driver with Multiple Input Triggers and Software-Free Operation

System Diagrams

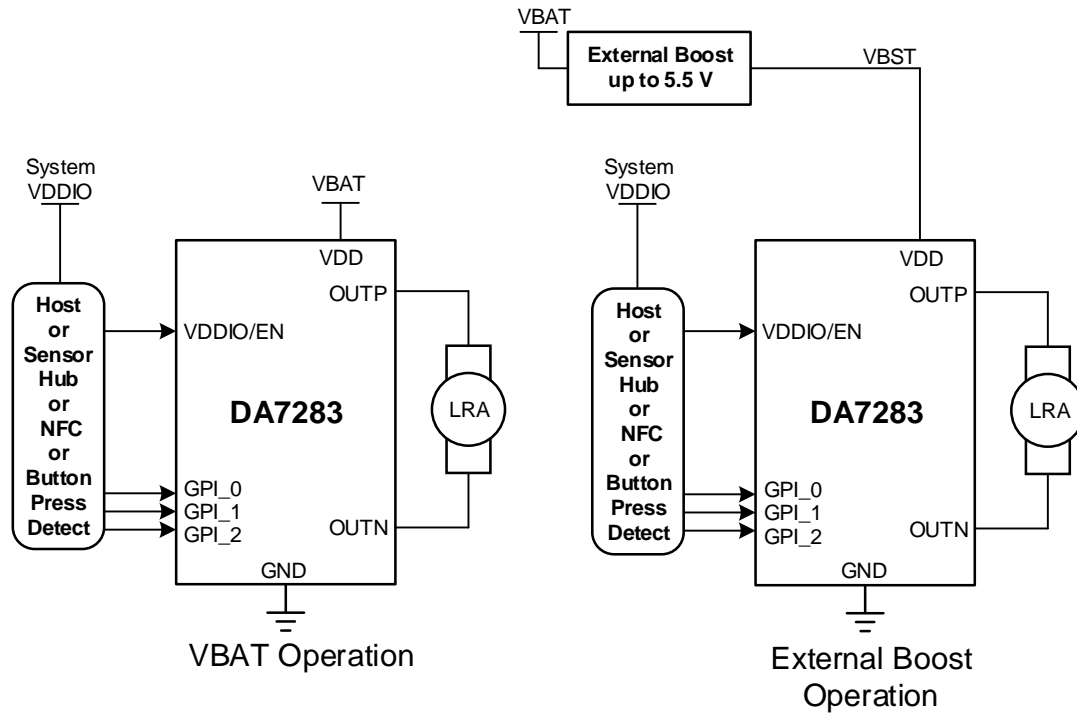

Figure 1: System Diagrams

Ultra-Low Power LRA Haptic Driver with Multiple Input Triggers and Software-Free Operation

Contents

General Description	1
Key Features	1
Applications	1
System Diagrams	2
Legal	4
Product Family	4
1 Terms and Definitions	5
2 Block Diagram	5
3 Pinout	6
4 Characteristics	7
4.1 Absolute Maximum Ratings	7
4.2 Recommended Operating Conditions.....	7
4.3 Electrical Characteristics.....	8
4.4 Timing Characteristics.....	9
4.5 Thermal Characteristics	9
5 Functional Description	10
5.1 Features Description	10
5.2 Functional Modes.....	13
5.3 Advanced Operation	16
6 Package Information	17
6.1 WLCSP Package Outline	17
6.2 QFN Package Outline	18
6.3 Moisture Sensitivity Level.....	19
6.4 WLCSP Handling	19
6.5 Soldering Information	19
7 Ordering Information	20
8 Application Information	20
9 Layout Guidelines	21

Figures

Figure 1: System Diagrams	2
Figure 2: DA7283 Block Diagram	5
Figure 3: DA7283 Pinout Diagrams (Top View) for WLCSP and QFN	6
Figure 4: LRA Output Acceleration Swept in Frequency with Constant Power Input Signal	10
Figure 5: System State Diagram	13
Figure 6: Simple GPI Behavior	14
Figure 7: Generating 100 ms Sequence Using GPI_1	15
Figure 8: Complex Sequence Generation using GPIs	15
Figure 9: 200 ms Haptic Sequence Oscilloscope Image	15
Figure 10: Optional Calibration Sequence	16
Figure 11: Automatic Output Limiting	16

Ultra-Low Power LRA Haptic Driver with Multiple Input Triggers and Software-Free Operation

Figure 12: WLCSP Package Outline Drawing	17
Figure 13: QFN Package Outline Drawing	18
Figure 14: External Components Diagram	20
Figure 15: WLCSP Example PCB Layout	21
Figure 16: QFN Example PCB Layout	21

Tables

Table 1: DA728x Feature Comparison	4
Table 2: Pin Description	6
Table 3: Pin Type Definition	6
Table 4: Absolute Maximum Ratings	7
Table 5: Recommended Operating Conditions	7
Table 6: Current Consumption	8
Table 7: Electrical Characteristics	8
Table 8: Timing Characteristics	9
Table 9: WLCSP Thermal Ratings	9
Table 10: QFN Thermal Ratings	9
Table 11: GPI Drive Level Behavior	14
Table 12: GPI Trigger Ranges	14
Table 13: MSL Classification	19
Table 14: Ordering Information	20

Legal

NOTWITHSTANDING ANYTHING TO THE CONTRARY IN THIS DOCUMENT OR IN ANY OTHER AGREEMENT, CUSTOMER ACKNOWLEDGES THAT THE PRODUCTS ARE PROVIDED WITHOUT ANY WARRANTY OF NON-INFRINGEMENT, AND THAT IF ANY LICENSE OR RIGHT IS REQUIRED TO BE OBTAINED FROM ANY THIRD PARTY, THIS RESPONSIBILITY SHALL REST SOLELY WITH CUSTOMER.

Product Family

Table 1: DA728x Feature Comparison

Feature	DA7280	DA7281	DA7282	DA7283
OFF state via VDDIO/EN pin	No	No	Yes	Yes
OFF state current	N/A	N/A	5 nA	5 nA
IDLE state current	360 nA	360 nA	680 nA	680 nA
Number of GPI sequence trigger pins	3	1	3	3
I ² C interface	Yes	Yes	Yes	No
Multiple I ² C addressing	No	Yes	No	N/A
Operation without a host	No	No	No	Yes

Ultra-Low Power LRA Haptic Driver with Multiple Input Triggers and Software-Free Operation

1 Terms and Definitions

BEMF	Back electromotive force
CDM	Charged device model
EMI	Electromagnetic interference
ERC	Edge rate control
ESD	Electrostatic discharge
FET	Field-effect transistor
GND	Ground
GPI	General purpose input
Half-period	One half of the LRA resonant frequency period. For example, if $f_{LRA} = 200$ Hz, one half-period is 2.5 ms.
HBM	Human body model
LRA	Linear resonant actuator
PCB	Printed circuit board
PID	Proportional-Integral-Derivative
PoR	Power-on reset
PWM	Pulse width modulated
QFN	Quad flat no leads
RC	Resistor-capacitor
WLCSP	Wafer level chip scale package
PMIC	Power Management Integrated Circuit
NFC	Near Field Communication

2 Block Diagram

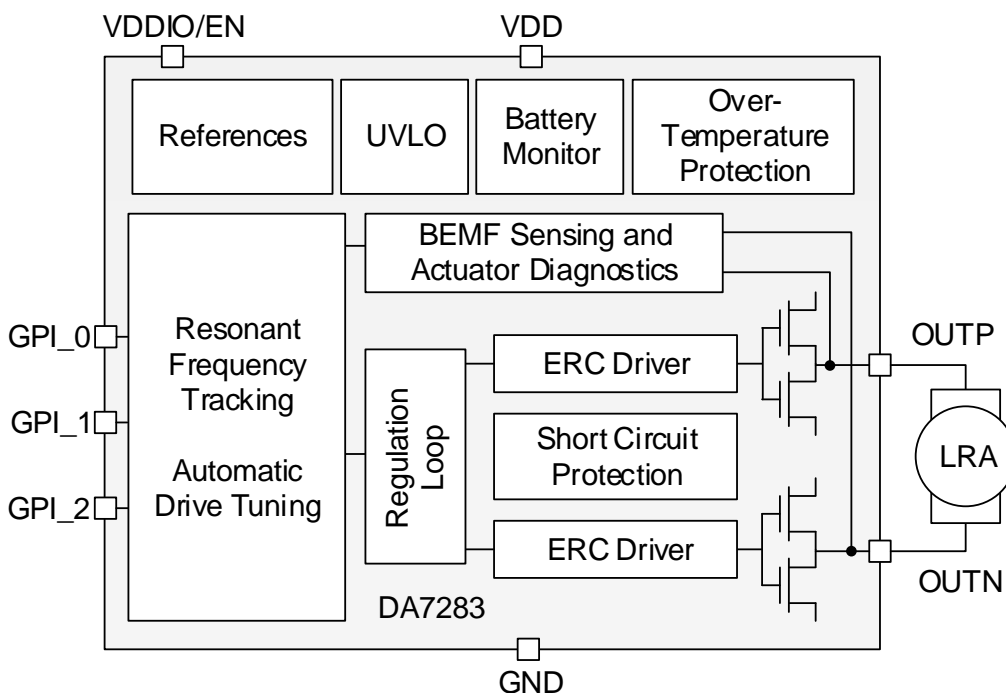

Figure 2: DA7283 Block Diagram

Ultra-Low Power LRA Haptic Driver with Multiple Input Triggers and Software-Free Operation

3 Pinout

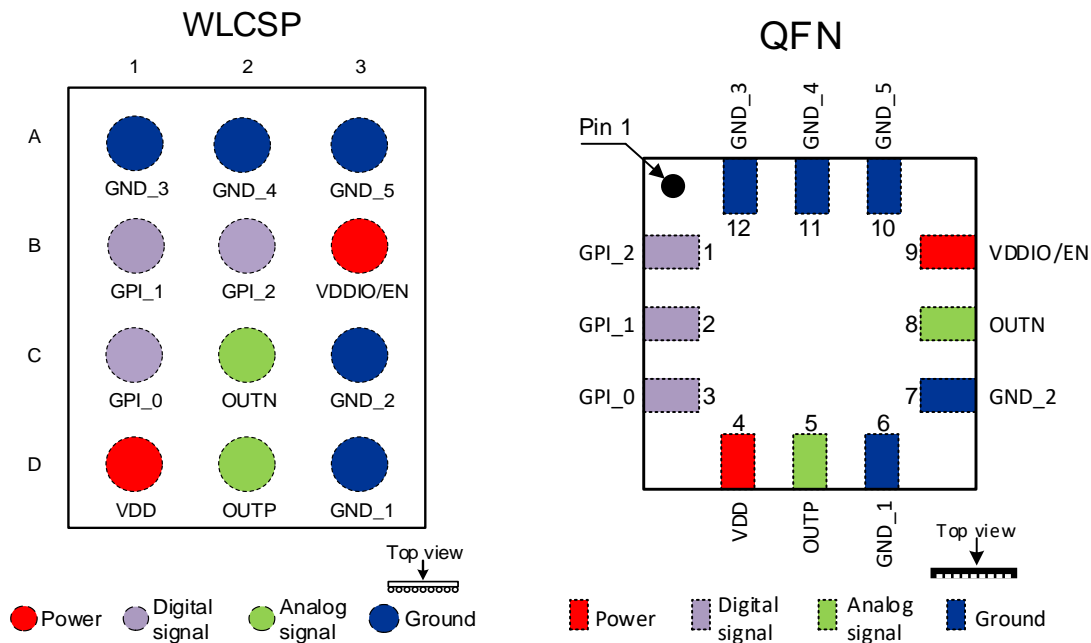

Figure 3: DA7283 Pinout Diagrams (Top View) for WLCSP and QFN

Table 2: Pin Description

Pin No. WLCSP	Pin No. QFN	Pin Name	Type (Table 3)	Description
A1	12	GND_3	GND	Ground
A2	11	GND_4	GND	Ground
A3	10	GND_5	GND	Ground
B1	2	GPI_1	DI	GPI sequence trigger 1
B2	1	GPI_2	DI	GPI sequence trigger 2
B3	9	VDDIO/EN	PWR	Digital IO supply / device enable function, active low. Connect to system VDDIO via push-pull GPIO or small-value resistor
C1	3	GPI_0	DI	GPI sequence trigger 0
C2	8	OUTN	AO	Haptic driver negative output
C3	7	GND_2	GND	Ground
D1	4	VDD	PWR	Haptic power supply; decouple to GND_1
D2	5	OUTP	AO	Haptic driver positive output
D3	6	GND_1	GND	Ground

Table 3: Pin Type Definition

Pin Type	Description	Pin Type	Description
DI	Digital input	AO	Analog output
DO	Digital output	PWR	Power
DIO	Digital input/output	GND	Ground

Ultra-Low Power LRA Haptic Driver with Multiple Input Triggers and Software-Free Operation

4 Characteristics

4.1 Absolute Maximum Ratings

Stresses beyond those listed under Absolute Maximum Ratings may cause permanent damage to the device. These are stress ratings only, so functional operation of the device at these or any other conditions beyond those indicated in the operational sections of the specification are not implied. Exposure to Absolute Maximum Rating conditions for extended periods may affect device reliability.

Table 4: Absolute Maximum Ratings

Parameter	Description	Conditions	Min	Max	Unit
V _{DD}	Haptic power supply (battery or regulated rail)	Referenced to GND	-0.3	6	V
V _{DDIO_EN}	Digital IO supply (VDDIO) and device enable		-0.3	6	V
V _{OUTN}	Haptic driver negative output		-0.3	6	V
V _{OUTP}	Haptic driver positive output		-0.3	6	V
V _{GPI}	General purpose inputs		-0.3	6	V
T _A	Operating ambient temperature		-40	85	°C
T _J	Operating junction temperature		-40	125	°C
T _{STG}	Storage temperature		-65	150	°C
ESD _{HBM}	ESD protection	Human Body Model (HBM) All non-exposed pins	4		kV
ESD _{CDM}	ESD protection	Charged Device Model (CDM)	1		kV

4.2 Recommended Operating Conditions

Unless otherwise noted, the parameters listed in [Table 5](#) are valid for T_A = 25 °C, V_{DD} = 3.8 V, and V_{DDIO_EN} = 1.8 V.

Table 5: Recommended Operating Conditions

Parameter	Description	Min	Typ	Max	Unit
V _{DD}	Haptic power supply (battery or regulated rail)	2.8	3.8	5.5	V
V _{DDIO_EN}	Digital IO supply (VDDIO) and device enable (Note 1)	1.35	1.8	5.5	V
V _{GPI}	GPI pins (GPI_0, GPI_1, and GPI_2) voltage level (Note 2)	1.35	1.8	5.5	V
C _{LD}	Capacitance to ground on OUTP and OUTN			1	nF
Z _{LD}	Nominal LRA DC impedance	8		25	Ω
L _{LD}	Nominal LRA inductance	25	100	1000	μH
f _{LRA}	Nominal LRA resonant frequency	160		240	Hz
V _{LRA}	LRA voltage rating	1.2			V _{RMS}

Note 1 The supply voltage level at the VDDIO/EN, GPI_0, GPI_1, and GPI_2 pins must be equal.

Note 2 Ensure that (V_{DDIO_EN} = V_{GPI}) ≤ V_{DD}

Note: When selecting LRAs to be driven by DA7283, ensure that their characteristics are within the recommended range. If the target LRA characteristics are outside [Table 5](#) specifications or if more sophisticated features are needed, use the I²C controlled DA7280, DA7281, or DA7282 devices.

Ultra-Low Power LRA Haptic Driver with Multiple Input Triggers and Software-Free Operation

4.3 Electrical Characteristics

Unless otherwise noted, the parameters listed in Table 6, Table 7, and Table 8 are valid for $T_A = 25\text{ }^\circ\text{C}$, $V_{DD} = 3.8\text{ V}$, and $V_{DDIO_EN} = 1.8\text{ V}$.

Table 6: Current Consumption

Parameter	Description	Conditions	Min	Typ	Max	Unit
I _{Q_OFF}	VDD current in OFF state	$V_{DDIO_EN} = 0\text{ V}$		5		nA
I _{Q_IDLE}	VDD current in IDLE state	System waiting for playback request		0.68	1	μA
I _{Q_EN}	VDDIO/EN pin current	$V_{DDIO_EN} = \text{system VDDIO}$		0.13		μA
I _{Q_NO_LD}	VDD current with no load	High-impedance load > 10 M Ω , H-bridge switching		1.35	1.5	mA

Table 7: Electrical Characteristics

Parameter	Description	Conditions	Min	Typ	Max	Unit
I _{SHRT}	Short circuit protection threshold	Short to GND or VDD	400	500	600	mA
I _{OUT_MAX}	Maximum drive current			230		mA
f _{TRCK_LRA}	LRA frequency tracking range	Automatic tracking limits	150	200	250	Hz
f _{TRCK_ACC_LRA}	LRA frequency tracking accuracy	Frequency tracking accuracy during playback		0.5		Hz
f _{OUT_PWM}	PWM output frequency	OUTP and OUTN switching frequency	183	187.5	192	kHz
ERC	Output switching pins edge rate control slope	OUTP and OUTN slope		100		mV/ns
R _{DS_ON}	H-bridge drain to source resistance when on	High side plus low side FETs		2		Ω
Z _{FLT_UZ}	Actuator under-impedance threshold			4		Ω
Z _{FTL_OZ}	Over-impedance threshold			50		Ω
Z _{OUT_OFF}	Output impedance when H-bridge not switching	Pull-down to GND		15		k Ω
V _{DD_POR_FALL}	VDD Power-on-Reset (PoR) falling threshold		2.4	2.55	2.7	V
V _{IH}	GPI high level input logic voltage level	Measured relative to V_{DDIO_EN}	0.7 *			V
V _{IL}	GPI low level input logic voltage level	Measured relative to V_{DDIO_EN}			0.3 *	V

Ultra-Low Power LRA Haptic Driver with Multiple Input Triggers and Software-Free Operation

4.4 Timing Characteristics

Table 8: Timing Characteristics

Parameter	Description	Conditions	Min	Typ	Max	Unit
t _{ON}	Cold boot to IDLE state time	V _{DD} present; V _{DDIO_EN} = V _{DDIO}			1.5	ms
t _{OUT_IDLE}	Time to output from IDLE state	From GPI or I ² C trigger to output drive		0.75		ms

4.5 Thermal Characteristics

Table 9: WLCSP Thermal Ratings

Parameter	Description (Note 1)	Min	Typ	Max	Unit
R _{θJA}	Junction-to-ambient thermal resistance		90.3		°C/W
R _{θJC_TOP}	Junction-to-case (top) thermal resistance		43.6		°C/W
R _{θJB}	Junction-to-board thermal resistance		49.0		°C/W
Ψ _{JT}	Junction-to-top characterization parameter		6.4		°C/W
Ψ _{JB}	Junction-to-board characterization parameter		45.8		°C/W

Note 1 Multilayer JEDEC standard, still air, ambient temperature 25 °C, simulated value.

Table 10: QFN Thermal Ratings

Parameter	Description (Note 1)	Min	Typ	Max	Unit
R _{θJA}	Junction-to-ambient thermal resistance		88.2		°C/W
R _{θJC_TOP}	Junction-to-case (top) thermal resistance		54.6		°C/W
R _{θJB}	Junction-to-board thermal resistance		39.3		°C/W
Ψ _{JT}	Junction-to-top characterization parameter		3.4		°C/W
Ψ _{JB}	Junction-to-board characterization parameter		50.0		°C/W
R _{θJC_BOTTOM}	Junction-to-case (bottom) thermal resistance		4.4		°C/W

Note 1 Multilayer JEDEC standard, still air, ambient temperature 25 °C, simulated value.

Ultra-Low Power LRA Haptic Driver with Multiple Input Triggers and Software-Free Operation

5 Functional Description

DA7283 is a haptic driver designed to drive linear resonant actuators (LRAs). The power-optimized architecture and advanced closed-loop digital algorithms achieve a high-fidelity haptic drive. It features three GPI inputs which allow haptic playback of short clicks and complex waveforms at two different levels of drive signal. DA7283 does not require another control interface or device programming to support a specific actuator.

The device controls the level of drive across the load and senses the movement of the actuator. The driven waveform is generated by a current regulated loop using a high-frequency PWM modulation. The differential output drive features a switching regulator architecture with H-bridge differential drive across the load at a frequency of 187.5 kHz.

DA7283 implements continuous resonant frequency tracking while driving an LRA to track the mechanical resonance of the actuator through closed-loop control. This maximizes electrical to mechanical energy conversion efficiency and is especially useful in applications such as operating system notifications and alarms.

5.1 Features Description

LRA Drive Capability

DA7283 drives LRA actuators with parameters within the specified limits in [Table 5](#).

No Need to Program the Device

DA7283 does not require any programming of actuator datasheet characteristics. The device playback is controlled by GPI inputs only and does not need an SPI or I²C interface. DA7283 haptic playback can be triggered directly by the interrupt output of an NFC device, a touchscreen controller, capacitive touch sensors, or a PMIC. More complex sequencing is also possible based on GPI trigger timing, see [Section 5.2.2](#).

Automatic LRA Resonant Frequency Tracking

LRA resonant frequency shifts over time due to changing operating conditions, such as temperature or position, and manufacturing spread. LRAs are high-Q systems; if driven at a fixed frequency, the consequences are loss of electrical to mechanical energy conversion efficiency, weaker than nominal actuator acceleration output, and significant part-to-part variation in the end-product haptic feel.

[Figure 4](#) illustrates that if the drive frequency is fixed, for example at 200 Hz, variation in the resonant peak of only 10 Hz can result in a loss of 50 % of the output acceleration.

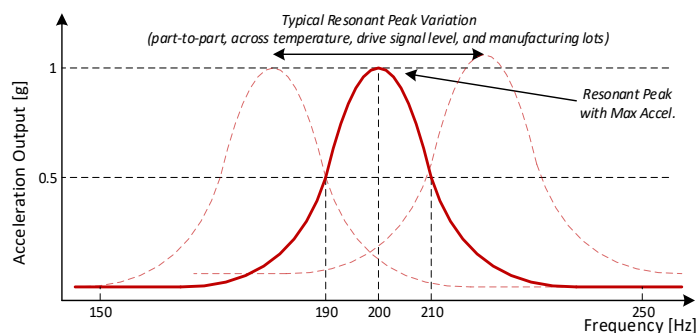

Figure 4: LRA Output Acceleration Swept in Frequency with Constant Power Input Signal

For a consistent user experience, DA7283 automatically locks onto and tracks the resonant frequency of the LRA through active back electromotive force (BEMF) sensing and closed-loop digital control. This ensures optimal output acceleration on every individual LRA throughout its lifetime and consistent part-to-part haptic feedback in the final product.

Ultra-Low Power LRA Haptic Driver with Multiple Input Triggers and Software-Free Operation

Ultra-Low Power Consumption when Disabled

In the OFF state when $V_{DDIO_EN} = 0\text{ V}$, DA7283 has an ultra-low current consumption from the VDD power supply, at typically 5 nA. This is the lowest power state of the device. In the OFF state the device is fully reset and its internal state lost, see Sections 5.2.1 and 5.3.3.

Low Latency GPI Wake-Up from Low Power Consumption IDLE State

The device has low latency (0.75 ms) wake-up from IDLE state, which takes typically 0.68 μA of current from V_{DD} . Wake-up is triggered by GPI activity requesting playback and DA7283 returns automatically to IDLE state after completing the requested playback. The device retains its setup in all states (including IDLE) apart from the OFF state, see Section 5.2.1.

Three GPI Sequence Triggers

DA7283 supports up to three GPI inputs which can be used to trigger low-latency playback of three specific effects from IDLE state. Triggering is activated on events caused by falling edges. The user can choose to create more complex effects by modulating the GPI triggering, see Section 5.2.2.

Differential PWM Output Drive

DA7283 includes a full H-bridge differential output PWM drive that has the advantage of maximizing the power delivered to the LRA from a given supply. This doubles the voltage swing across the actuator and significantly increases system efficiency relative to a single transistor/LDO solution in legacy LRA applications.

Current Driven System

The device outputs regulated current, rather than voltage, which allows BEMF tracking without the need to stop driving to sense the BEMF. This maximizes power delivery to the actuator per unit time when compared to voltage driven solutions, resulting in shorter and sharper haptic clicks. In addition, constant current drive provides constant force into the actuator independently of BEMF amplitude.

Rate Control for EMI suppression

Switching node edge rate control (ERC) on the OUPN and OUTN pins reduces electromagnetic interference (EMI) and electrical interference via capacitive coupling in the end application. This eliminates any need for resistor-capacitor (RC) or ferrite bead filtering of the outputs, resulting in simpler system design and a lower-cost bill of materials.

Automatic Short Circuit Protection

Automatic low-latency short circuit protection detects shorts on the OUPN and OUTN pins to supply, ground, or between OUPN and OUTN, and protects DA7283 by forcing the H-bridge into a high-impedance state. Once the short circuit protection is triggered, playback is stopped. The device will then attempt to drive only at the next GPI request for playback.

Automatic Over-Temperature Protection

Automatic over-temperature protection detects when the device temperature exceeds 125 °C and protects DA7283 by stopping playback. The device will then attempt to drive only at the next GPI request for playback.

Automatic Under-Voltage Lockout Protection

Automatic under-voltage lockout protection (UVLO) detects when V_{DD} drops below 2.8 V and protects DA7283 by stopping playback. The device will then attempt to drive only at the next GPI request for playback.

Ultra-Low Power LRA Haptic Driver with Multiple Input Triggers and Software-Free Operation

Automatic Haptic Playback Timeout

The longest sequences provided by the device are 60 seconds long via GPI_1 and GPI_2. If the host crashes after starting a pattern and does not send a negative edge to stop it, DA7283 will stop playback after 60 seconds and return to an IDLE state. This guarantees that the haptic device will not completely discharge the battery in case of a software crash.

Supply Monitoring and Automatic Output Limiting

DA7283 monitors the power supply voltage level and adjusts the drive voltage accordingly, so that the output does not clip to the supply voltage. This feature guarantees controlled output allowing continued resonant frequency tracking functionality even when the device is operating under low power supply conditions or heavy battery load, see Section 5.3.2.

Small Solution Footprint

Available in an ultra-small 1.35 mm x 1.75 mm, 0.4 mm pitch, 0.545 mm height, 3 x 4 WLCSP, or a 3.0 mm x 3.0 mm, 0.65 mm pitch, 0.78 mm height, 12 lead QFN package, DA7283 minimizes the required PCB size and overall solution cost. In the typical application case, only a single 100 nF decoupling capacitor is required. See Section 8 and Section 9.

Ultra-Low Power LRA Haptic Driver with Multiple Input Triggers and Software-Free Operation

5.2 Functional Modes

5.2.1 System States

The device states and the transitions into and out of each state are shown in Figure 5. When a power supply is applied on the VDD pin and VDDIO/EN pin is set high, DA7283 loads its initial boot settings. Once BOOT is complete, DA7283 remains in the IDLE state, ensuring low power consumption and low start-up latency, and awaits GPI triggering. DA7283 enters the DRIVE state and starts playback when one of the three GPI pins receives a falling edge from the host controlling the device, see Section 5.2.2. On playback completion, caused either by a GPI triggered sequence reaching its end or a second negative edge on any of the GPIs, DA7283 leaves the DRIVE state and returns to IDLE.

If a fault condition arises during playback, DA7283 cancels the ongoing playback and returns to the IDLE state. Possible fault conditions include an UVLO event, an over-temperature event, a short circuit protection event, and an actuator over- or under-impedance event.

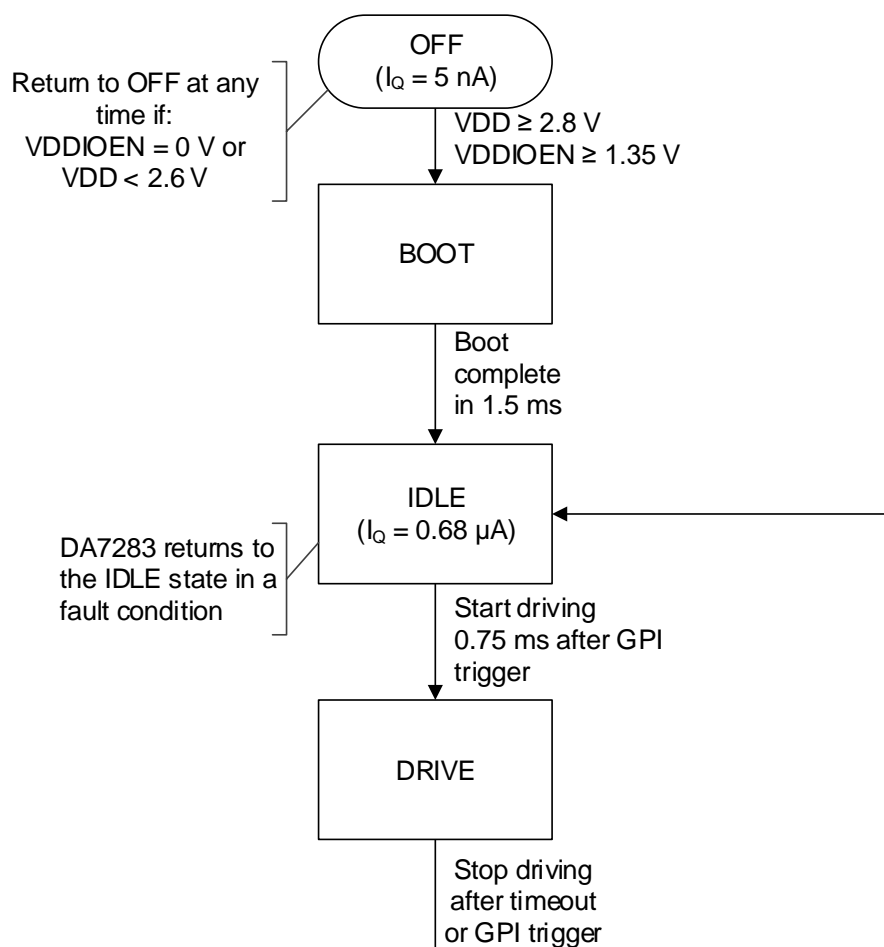

Figure 5: System State Diagram

Note: An optional one-time device configuration can be performed after the initial BOOT sequence by going once through the DRIVE state via GPI_2, see Section 5.3.1.

Ultra-Low Power LRA Haptic Driver with Multiple Input Triggers and Software-Free Operation

5.2.2 Playback via Edge Triggering

DA7283 playback is triggered by a negative edge provided to any of the three device GPIs. Their configuration is summarized in Table 11. When a sequence finishes, the device automatically goes to the low power IDLE state and honors any subsequent playback requests, see Figure 6.

Table 11: GPI Drive Level Behavior

GPI	Drive Level	Duration	Sequence Description
GPI_0	1.8 V _{RMS}	25 ms drive, 10 ms brake, 20 ms silence	Click effect
GPI_1	1.8 V _{RMS}	60 seconds drive	Maximum strength, buzz effect
GPI_2	1 V _{RMS}	60 seconds drive	Medium strength, buzz effect

The majority of LRAs are rated at 1.2 V_{RMS} or in the range of 1.8 V_{RMS} to 2.5 V_{RMS}. Table 12 shows the recommended triggers for the two ranges. If more sophisticated features are needed, use the I²C controlled DA7280, DA7281, and DA7282 devices.

Table 12: GPI Trigger Ranges

LRA Rating (V _{RMS})	GPI Triggers to Use	Comments
1.2	GPI_2 only	GPI_0 and GPI_2 drive above the 1.2 V _{RMS} rating. They may be used only for short time periods at the system designer discretion.
1.8 to 2.5	GPI_0, GPI_1, GPI_2	Any GPI trigger may be used

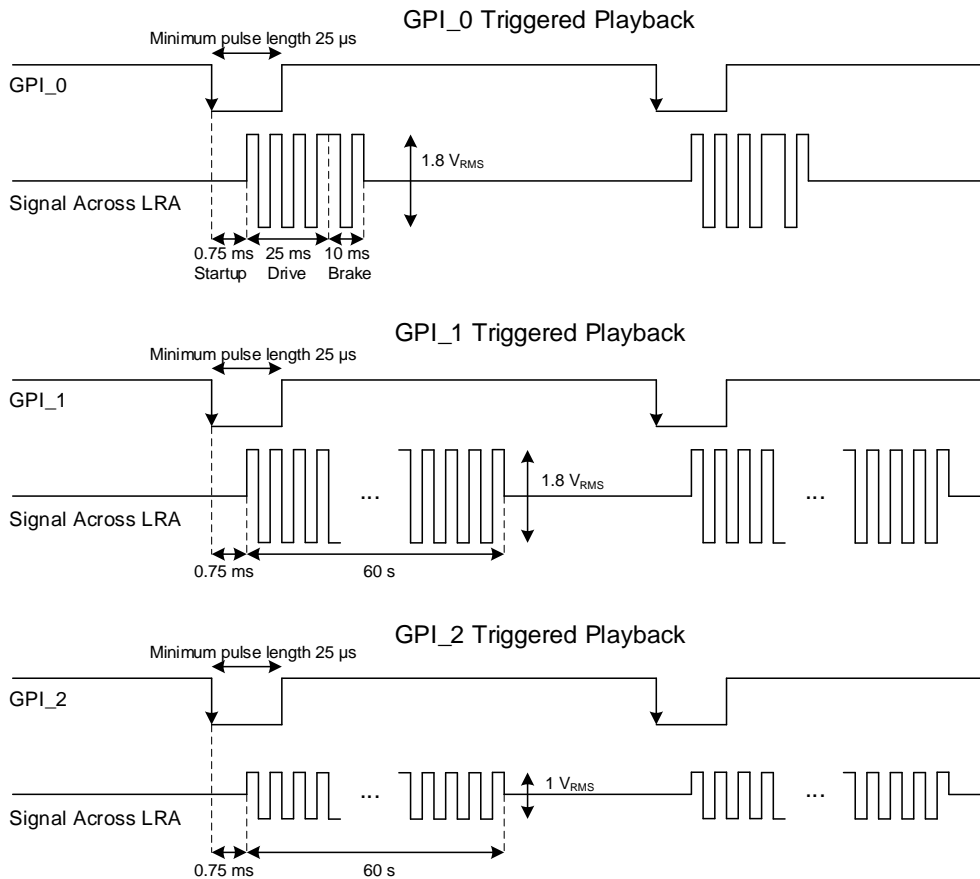

Figure 6: Simple GPI Behavior

Ultra-Low Power LRA Haptic Driver with Multiple Input Triggers and Software-Free Operation

If a second negative edge on any GPI is received by the device while haptic playback is ongoing, DA7283 will terminate the sequence being played without starting another sequence and go to IDLE; a third negative edge will trigger playback again. This setup allows the user to modulate the length of the sequence being played by changing the timing between a *start* negative edge and a *stop* negative edge to produce a sequence with a length between 5 ms and 60 s using GPI_1 and GPI_2. [Figure 7](#) shows GPI_1 creating a 100 ms *buzz* by using two sequential negative edges:

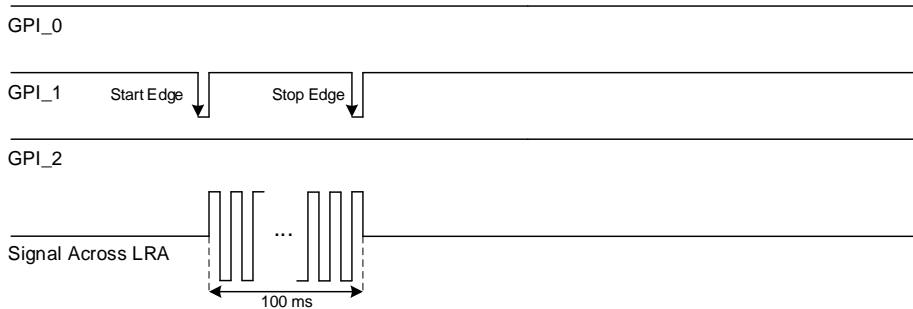

Figure 7: Generating 100 ms Sequence Using GPI_1

More complex behavior is possible by combining all three GPIs. For example, by triggering both GPI_1 and GPI_2 at different times, a strong short *buzz* followed by a short silence and a longer *buzz* at a lower amplitude are obtained to create a specific haptic sequence, see [Figure 8](#):

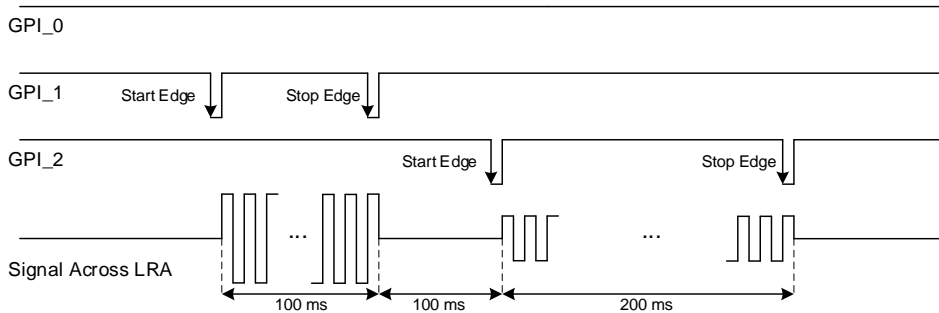

Figure 8: Complex Sequence Generation using GPIs

An oscilloscope image showing a 200 ms long haptic sequence created by two sequential negative edges on the GPI_2 pin is shown in [Figure 9](#):

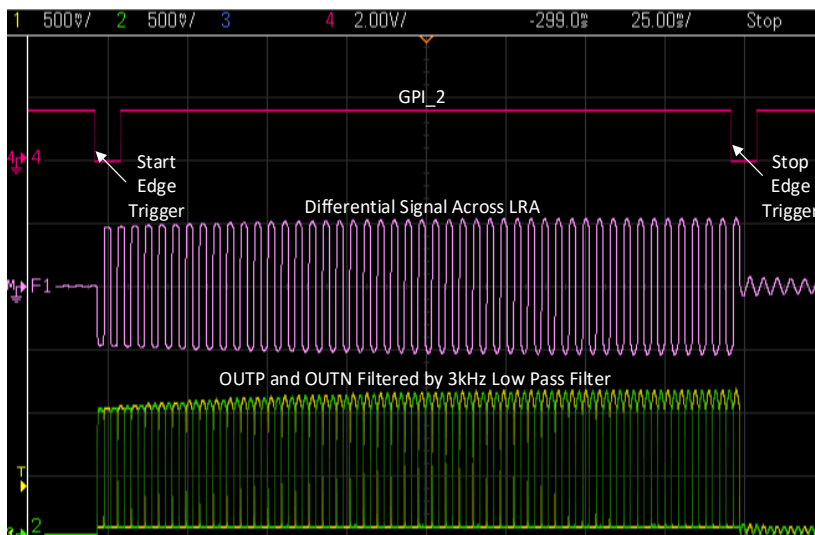

Figure 9: 200 ms Haptic Sequence Oscilloscope Image

Ultra-Low Power LRA Haptic Driver with Multiple Input Triggers and Software-Free Operation

5.3 Advanced Operation

5.3.1 Device Configuration

Optional one-time configuration is recommended on enabling the device. It is done by creating one 250 ms long sequence, see Figure 10. This allows DA7283 to automatically lock to the LRA resonant frequency, adjust its drive level for the actuator impedance, and use this information in subsequent playbacks. If the VDDIO/EN pin is set low, information from this configuration sequence is lost. The initial configuration can be skipped; however, haptic playback consistency may be reduced during the first playback after enabling the device.

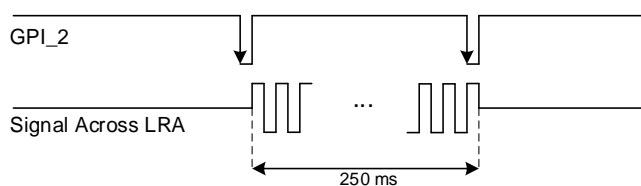

Figure 10: Optional Calibration Sequence

5.3.2 Supply Monitoring and Automatic Output Limiting

DA7283 monitors the level of the supply during playback and uses this information to prevent the device from clipping to supply by limiting the drive to a value 1.12 V below the supply, see Figure 11. This functionality allows the frequency tracking loop to work across all supply conditions and provides limiting of the power across the LRA for low supply values to prevent a battery brownout.

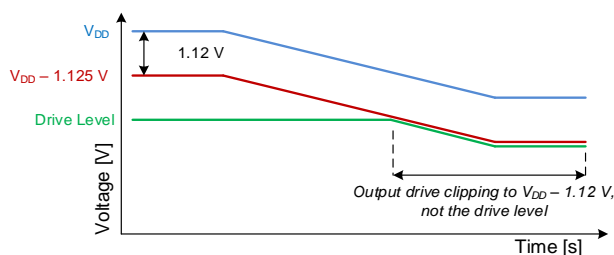

Figure 11: Automatic Output Limiting

5.3.3 VDDIO/EN Pin Control

The VDDIO/EN pin controls the entry and exit of the device from the OFF state. When $V_{DDIO_EN} = 0$ V, DA7283 is OFF and consumes typ. 5 nA of current from the VDD pin. Setting $V_{DDIO_EN} \geq 1.35$ V enables the device and after the initial boot sequence it reaches the IDLE state with typ. 680 nA of current consumption. Note that the device will have been hardware reset when it comes out of the OFF mode.

For lowest OFF mode current consumption control the enable function via a host-side GPIO push-pull that connects the VDDIO/EN pin either to GND or to the system VDDIO supply.

If the VDDIO/EN pin is only needed as a device hardware reset, where it will only be pulled low for a short time (therefore IDLE state power consumption is not an issue), a possible system solution is to use an open-drain output with a pull-up resistor to the system VDDIO supply. In this configuration, it is recommended to use a pull-up resistor smaller than 10 k Ω .

Ultra-Low Power LRA Haptic Driver with Multiple Input Triggers and Software-Free Operation

6 Package Information

6.1 WLCSP Package Outline

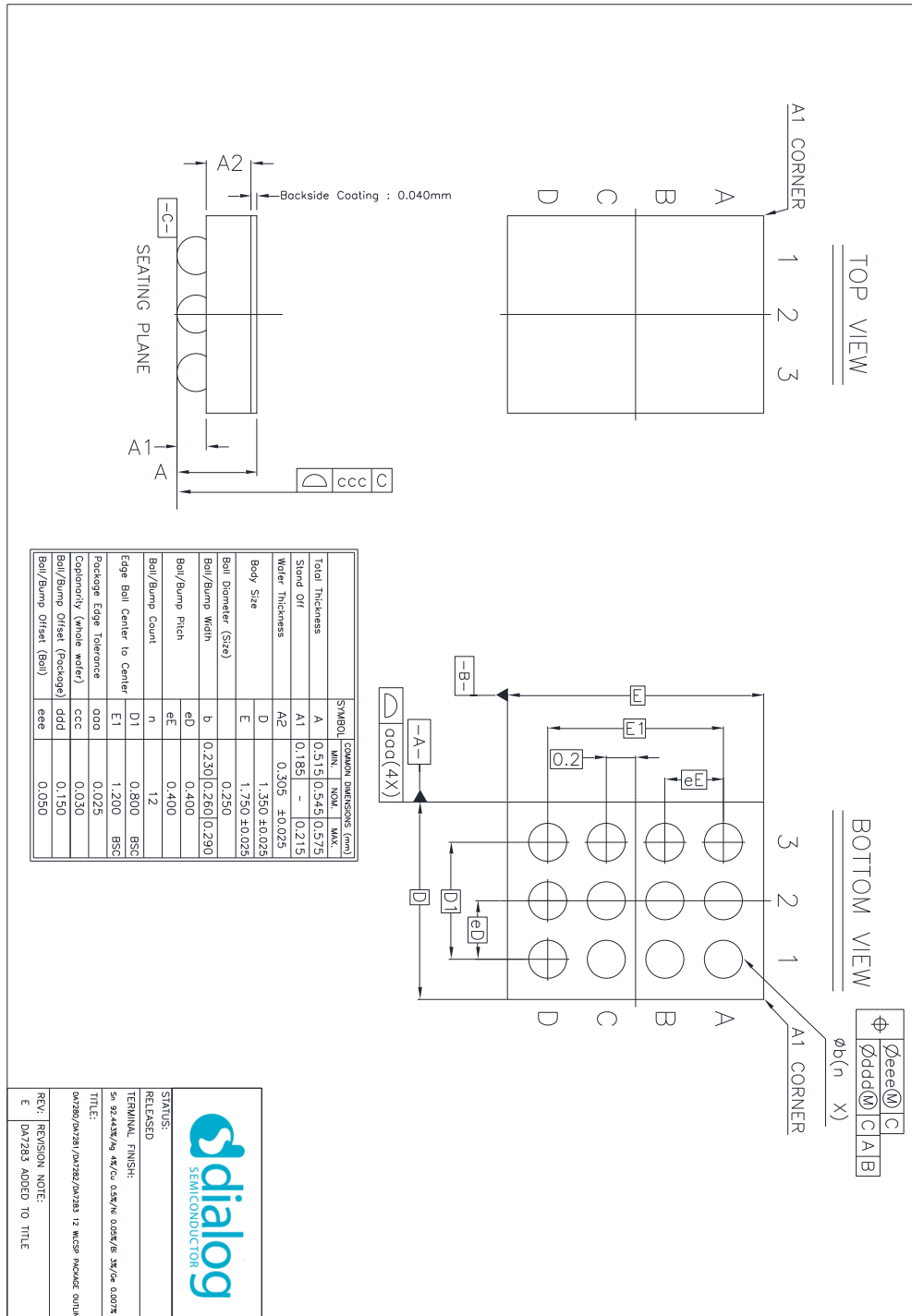

Figure 12: WLCSP Package Outline Drawing

Ultra-Low Power LRA Haptic Driver with Multiple Input Triggers and Software-Free Operation

6.2 QFN Package Outline

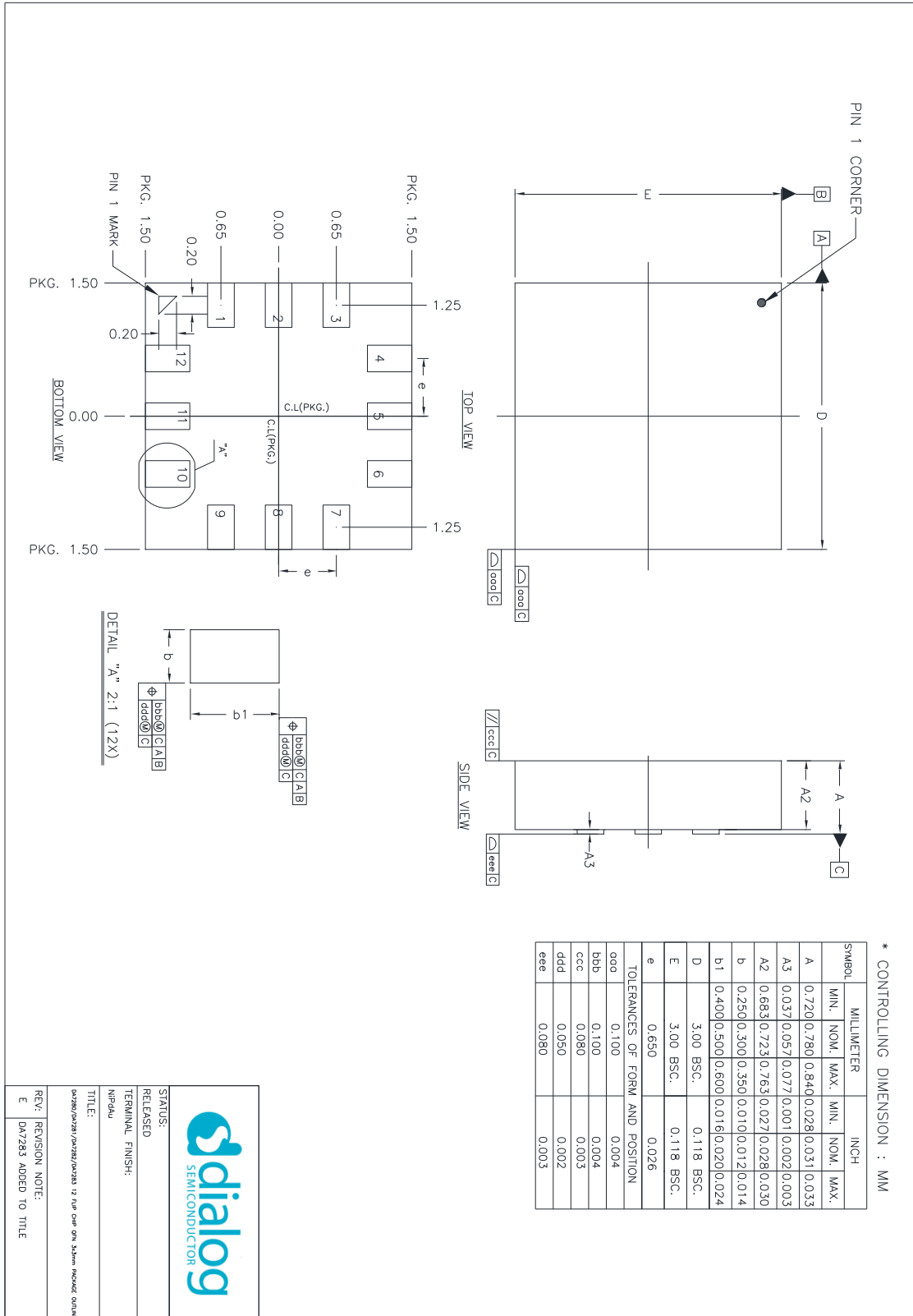

Figure 13: QFN Package Outline Drawing

Ultra-Low Power LRA Haptic Driver with Multiple Input Triggers and Software-Free Operation

6.3 Moisture Sensitivity Level

The Moisture Sensitivity Level (MSL) is an indicator for the maximum allowable time period (floor lifetime) in which a moisture sensitive plastic device, once removed from the dry bag, can be exposed to an environment with a specified maximum temperature and a maximum relative humidity before the solder reflow process. The MSL classification is defined in [Table 13](#).

For detailed information on MSL levels refer to the IPC/JEDEC standard J-STD-020, which can be downloaded from <http://www.jedec.org>.

The WLCSP package is qualified for MSL 1.

The QFN package is qualified for MSL 3.

Table 13: MSL Classification

MSL Level	Floor Lifetime	Conditions
MSL 4	72 hours	30 °C / 60 % RH
MSL 3	168 hours	30 °C / 60 % RH
MSL 2A	4 weeks	30 °C / 60 % RH
MSL 2	1 year	30 °C / 60 % RH
MSL 1	Unlimited	30 °C / 85 % RH

6.4 WLCSP Handling

Manual handling of WLCSP packages should be reduced to the absolute minimum. In cases where it is still necessary, a vacuum pick-up tool should be used. In extreme cases plastic tweezers could be used, but metal tweezers are not acceptable, since contact may easily damage the silicon chip.

Removal of a WLCSP package will cause damage to the solder balls. Therefore, a removed sample cannot be reused.

WLCSP packages are sensitive to visible and infrared light. Precautions should be taken to properly shield the chip in the final product.

6.5 Soldering Information

Refer to the IPC/JEDEC standard J-STD-020 for relevant soldering information. This document can be downloaded from <http://www.jedec.org>.

Ultra-Low Power LRA Haptic Driver with Multiple Input Triggers and Software-Free Operation

7 Ordering Information

The ordering number consists of the part number followed by a suffix indicating the packing method. For details and availability, please consult Dialog Semiconductor's [customer support portal](#) or your local sales representative.

Table 14: Ordering Information

Part Number	Package	Size (mm)	Shipment Form	Pack Quantity
DA7283-01V42	WLCSP	1.35 x 1.75	Tape and reel	4500
DA7283-01V4C	WLCSP	1.35 x 1.75	Tape and reel	250
DA7283-01FV2	QFN	3.0 x 3.0	Tape and reel	6000
DA7283-01FVC	QFN	3.0 x 3.0	Tape and reel	250

8 Application Information

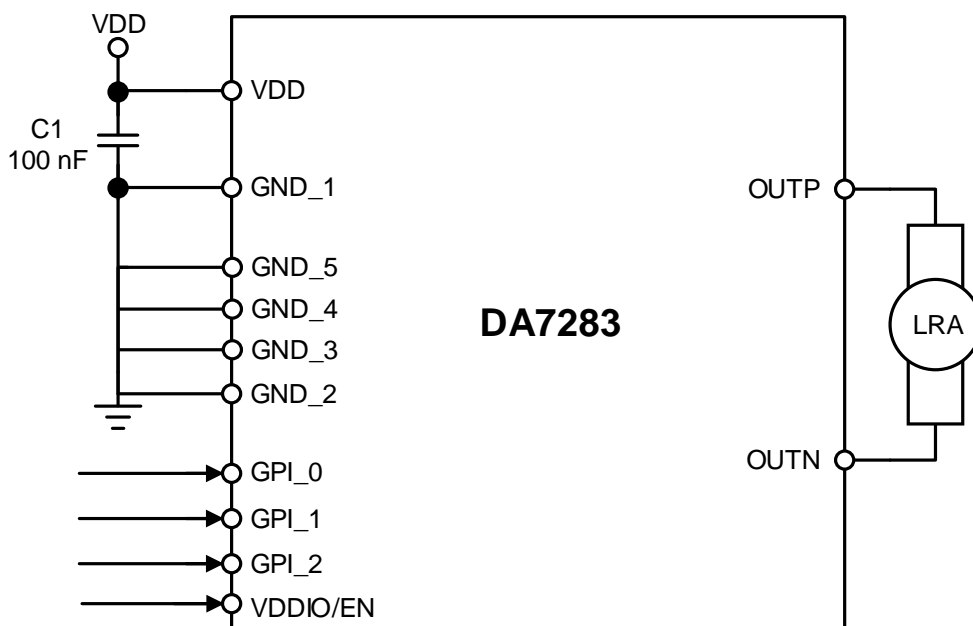

Figure 14: External Components Diagram

Note: Drive the GPI pins and the VDDIO/EN pin from the same voltage level.

Note: Ground any unused GPI pins.

Note: Due to ultra-low power considerations, GPI pins are true high impedance inputs and have no internal pulldown resistors. It is recommended to drive GPI pins either via a push-pull or open drain GPIO on the host side. In either case, the duration of the triggering pulse must be longer than 25 μ s. When using an open drain GPIO to trigger a haptic effect, the pullup resistor must be selected to satisfy the 25 μ s condition while considering PCB parasitic capacitance. A 10 k Ω resistor would satisfy most use cases.

Note: Capacitor C1 should be placed as close as possible to, and between, VDD and GND_1 pins. It removes high-frequency noise only; ensure additional decoupling (typ. 10 μ F) is included elsewhere in the system.

Ultra-Low Power LRA Haptic Driver with Multiple Input Triggers and Software-Free Operation

9 Layout Guidelines

For optimal layout, place the 100 nF capacitor C1 as close to the VDD and the GND_1 pins as possible. It is also advisable to use solid a ground plane under the device.

The QFN can be routed out on a single layer. It is recommended to connect GND_1 and GND_2 to a local ground plane on the top layer with a low-impedance via connection to the main ground plane, see Figure 16.

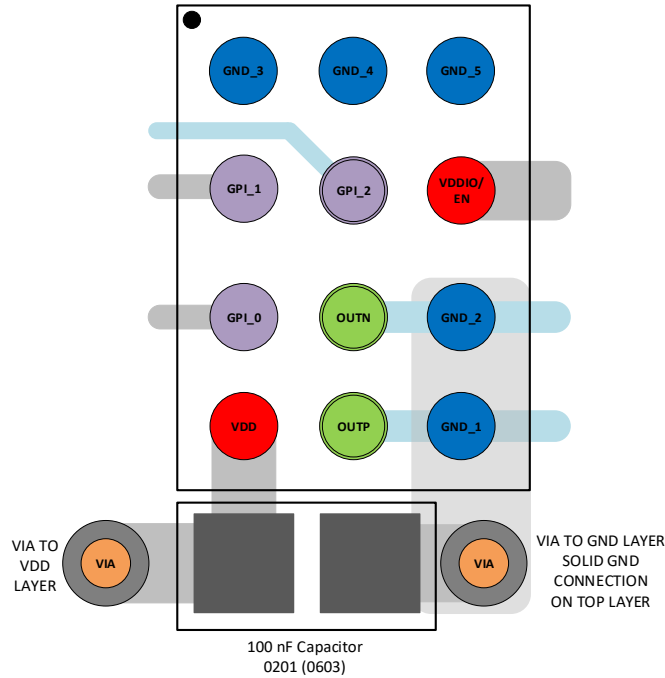

Figure 15: WLCSP Example PCB Layout

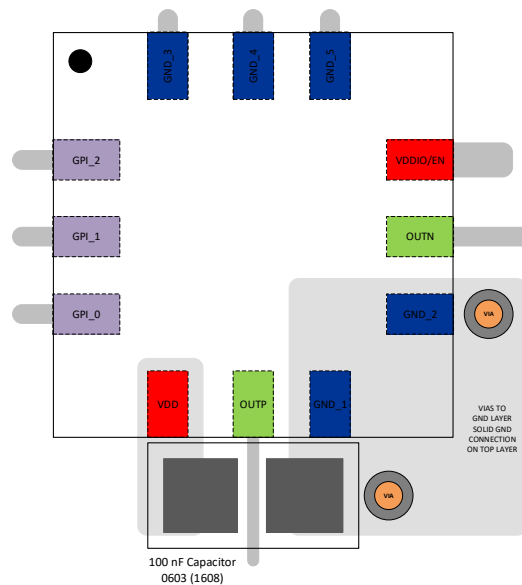

Figure 16: QFN Example PCB Layout

Ultra-Low Power LRA Haptic Driver with Multiple Input Triggers and Software-Free Operation

Status Definitions

Revision	Datasheet Status	Product Status	Definition
1.<n>	Target	Development	This datasheet contains the design specifications for product development. Specifications may be changed in any manner without notice.
2.<n>	Preliminary	Qualification	This datasheet contains the specifications and preliminary characterization data for products in pre-production. Specifications may be changed at any time without notice in order to improve the design.
3.<n>	Final	Production	This datasheet contains the final specifications for products in volume production. The specifications may be changed at any time in order to improve the design, manufacturing and supply. Major specification changes are communicated via Customer Product Notifications. Datasheet changes are communicated via www.dialog-semiconductor.com .
4.<n>	Obsolete	Archived	This datasheet contains the specifications for discontinued products. The information is provided for reference only.

Disclaimer

Unless otherwise agreed in writing, the Dialog Semiconductor products (and any associated software) referred to in this document are not designed, authorized or warranted to be suitable for use in life support, life-critical or safety-critical systems or equipment, nor in applications where failure or malfunction of a Dialog Semiconductor product (or associated software) can reasonably be expected to result in personal injury, death or severe property or environmental damage. Dialog Semiconductor and its suppliers accept no liability for inclusion and/or use of Dialog Semiconductor products (and any associated software) in such equipment or applications and therefore such inclusion and/or use is at the customer's own risk.

Information in this document is believed to be accurate and reliable. However, Dialog Semiconductor does not give any representations or warranties, express or implied, as to the accuracy or completeness of such information. Dialog Semiconductor furthermore takes no responsibility whatsoever for the content in this document if provided by any information source outside of Dialog Semiconductor.

Dialog Semiconductor reserves the right to change without notice the information published in this document, including, without limitation, the specification and the design of the related semiconductor products, software and applications. Notwithstanding the foregoing, for any automotive grade version of the device, Dialog Semiconductor reserves the right to change the information published in this document, including, without limitation, the specification and the design of the related semiconductor products, software and applications, in accordance with its standard automotive change notification process.

Applications, software, and semiconductor products described in this document are for illustrative purposes only. Dialog Semiconductor makes no representation or warranty that such applications, software and semiconductor products will be suitable for the specified use without further testing or modification. Unless otherwise agreed in writing, such testing or modification is the sole responsibility of the customer and Dialog Semiconductor excludes all liability in this respect.

Nothing in this document may be construed as a license for customer to use the Dialog Semiconductor products, software and applications referred to in this document. Such license must be separately sought by customer with Dialog Semiconductor.

All use of Dialog Semiconductor products, software and applications referred to in this document is subject to Dialog Semiconductor's [Standard Terms and Conditions of Sale](http://www.dialog-semiconductor.com), available on the company website (www.dialog-semiconductor.com) unless otherwise stated.

Dialog, Dialog Semiconductor and the Dialog logo are trademarks of Dialog Semiconductor Plc or its subsidiaries. All other product or service names and marks are the property of their respective owners.

© 2019 Dialog Semiconductor. All rights reserved.

RoHS Compliance

Dialog Semiconductor's suppliers certify that its products are in compliance with the requirements of Directive 2011/65/EU of the European Parliament on the restriction of the use of certain hazardous substances in electrical and electronic equipment. RoHS certificates from our suppliers are available on request.

Contacting Dialog Semiconductor

United Kingdom (Headquarters)

Dialog Semiconductor (UK) LTD
Phone: +44 1793 757700

Germany

Dialog Semiconductor GmbH
Phone: +49 7021 805-0

The Netherlands

Dialog Semiconductor B.V.
Phone: +31 73 640 8822

Email:

enquiry@diasemi.com

North America

Dialog Semiconductor Inc.
Phone: +1 408 845 8500

Japan

Dialog Semiconductor K. K.
Phone: +81 3 5769 5100

Taiwan

Dialog Semiconductor Taiwan
Phone: +886 281 786 222

Web site:

www.dialog-semiconductor.com

Hong Kong

Dialog Semiconductor Hong Kong
Phone: +852 2607 4271

Korea

Dialog Semiconductor Korea
Phone: +82 2 3469 8200

China (Shenzhen)

Dialog Semiconductor China
Phone: +86 755 2981 3669

China (Shanghai)

Dialog Semiconductor China
Phone: +86 21 5424 9058