

Data Sheet 2511 Rev.—

Features

- Glass Passivated Die Construction
- Low Leakage
- Low Cost
- High Surge Current Capability
- Low Forward
- C-Band Terminal Construction

Mechanical Data

- Case: All Copper Case and Components Hermetically Sealed
- Terminals: Contact Areas Readily Solderable
- Polarity: Cathode to Case(Reverse Units Are Available Upon Request and Are Designated By An “R” Suffix, i.e. DD202R or DD204SR)
- Polarity: Red Color Equals Standard, Black Color Equals Reverse Polarity
- Mounting Position: Any

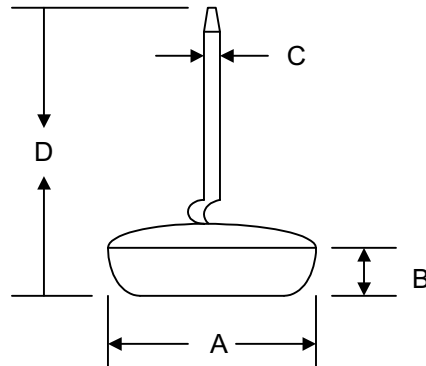

Dim	8.4mm Dish		9.5mm Dish	
	Min	Max	Min	Max
A	0.329(8.35)	0.333(8.45)	0.374(9.50)	0.383(9.72)
B	0.079(2.00)	0.085(2.16)	0.079(2.00)	0.085(2.16)
C	0.056(1.43)	0.058(1.47)	0.056(1.43)	0.058(1.47)
D	0.878(22.3)	—	0.878(22.3)	—

All Dimensions in inch(mm)

“S” Suffix Designates 8.4mm Dish
No Suffix Designates 9.5mm Dish

Maximum Ratings and Electrical Characteristics @T_A=25°C unless otherwise specified

Single Phase, half wave, 60Hz, resistive or inductive load.
For capacitive load, derate current by 20%.

Characteristic	Symbol	DD200/ S	DD201/ S	DD202/ S	DD203/ S	DD204/ S	DD205/ S	DD206/ S	Unit
Peak Repetitive Reverse Voltage Working Peak Reverse Voltage DC Blocking Voltage	V _{RRM} V _{RWM} V _R	50	100	200	300	400	500	600	V
RMS Reverse Voltage	V _{R(RMS)}	35	70	140	210	280	350	420	V
Average Rectified Output Current @T _A = 150°C	I _O	20							A
Non-Repetitive Peak Forward Surge Current 8.3ms Single half sine-wave superimposed on rated load (JEDEC Method)	I _{FSM}	400							A
Forward Voltage @I _F = 20A	V _{FM}	1.1							V
Peak Reverse Current @T _A = 25°C At Rated DC Blocking Voltage @T _A = 100°C	I _{RM}	100 500							μA
Typical Junction Capacitance (Note 1)	C _j	300							pF
Typical Thermal Resistance Junction to Case (Note 2)	R _{θJC}	1.0							K/W
Operating and Storage Temperature Range	T _J , T _{STG}	-65 to +175							°C

Note: 1. Measured at 1.0 MHz and applied reverse voltage of 4.0V D.C.
2. Thermal Resistance: Junction to case, single side cooled.