

Design Idea DI-35

TOPSwitch-GX

16 W Audio Amplifier Power Supply



Application	Device	Power Output	Input Voltage	Output Voltage	Topology
Audio Amplifier	TOP245P	16 W (35 W Peak)	85-265 VAC	16 V	Flyback

Design Highlights

- No heatsinks required!
- 77% efficiency (min), @ 85 VAC input/35 W output
- Low no-load input power: < 0.7 W @ 230 VAC input
- Low component count: 37, excluding I/O connectors
- Stable operation with or without 10,000 μ F output buffer capacitor
- Robust transformer design enables 35 W peak power
- Meets CISPR22B EMI with > 10 dB of margin
- Ideal for both class AB and class D audio amplifiers

Operation

Many of the built-in TOPSwitch-GX features have been used to reduce the component count, transformer size, and overall cost of this universal input flyback power supply. Designed around a TOP245P (DIP-8 package), the device uses PCB copper for its heatsink, eliminating the costs of both a heatsink and the installation labor. Output diode D7 is also cooled the same way.

Resistors R1 and R2 set the nominal Under-Voltage (UV) lockout and Overvoltage (OV) shutdown limits to 84 V and 378 V, respectively. UV lockout protects the supply from overheating at low line and eliminates power-up and power-down glitches. OV shutdown protects the power supply from line surges.

The EMI filter has been significantly simplified to three components (L1, CX1 and CY1), thanks to the built-in frequency jitter function of the TOPSwitch-GX family.

The RCD network of C4, R3, R4, and D5 limits (clamps) the peak voltage that the U1-DRAIN sees. A glass-passivated normal recovery diode (D5) recycles stored leakage energy, increasing overall efficiency. DRAIN ringing is dampened by R4 (which is necessary when a normal recovery diode is used).

The bias winding provides operating power and feedback current to the CONTROL pin of U1. The U2-LED, R8 and VR1 comprise the feedback circuit that senses the output voltage. The current through the U2-LED regulates the output voltage, by modulating the feedback current that flows into the CONTROL pin of U1.

Key Design Points

- Ensure that the control loop has enough phase margin at the extremes of the rated input voltage and output load, both with and without the output buffer capacitor.
- A 5% VR1 should be acceptable for an audio amplifier. Greater accuracy will require a 2% VR1.
- OV and UV thresholds are determined by: $V_{OV} = 225 \mu\text{A} \times (R1+R2)$ and $V_{UV} = 50 \mu\text{A} \times (R1+R2)$.

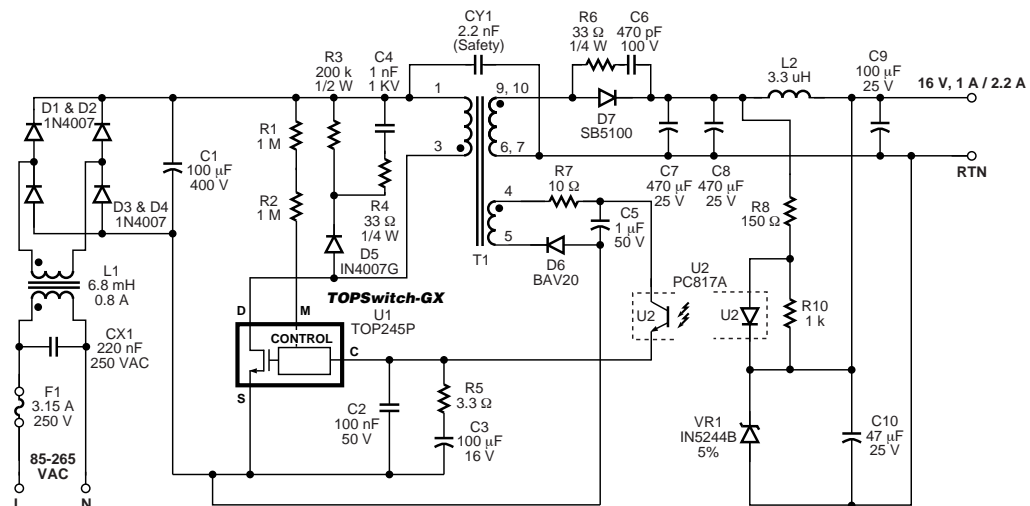

Figure 1. Audio Amplifier Power Supply.

PI-3731-012604

- Keep power loop layouts (primary and secondary) tight to minimize noise (EMI and output ripple) and power loss.
- At least 10 cm² of PCB copper area should be used for heatsinking.

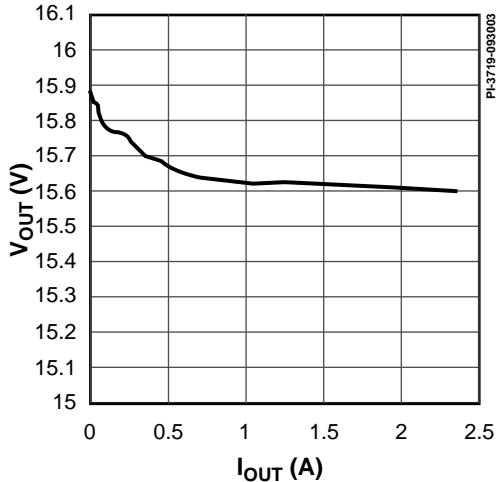

Figure 2. 115 VAC V-I Curve.

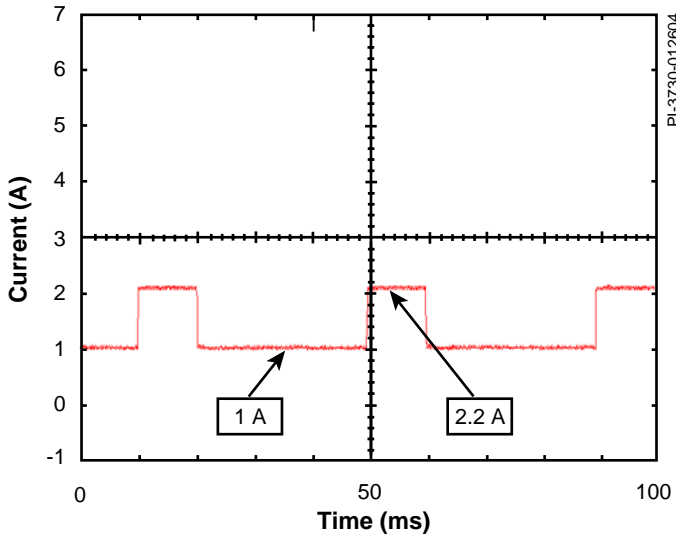

Figure 3. Load Current for Thermal Test. (10 ms/div)

TRANSFORMER PARAMETERS	
Core	Nippon Ceramic EF-25-NC-2H A _{LG} of 247 nH/T ²
Bobbin	Miles-Platts FE0100 with TBS-601 terminals
Winding Details	Primary: 65T, 2 layers, 28 AWG Secondary: 9T, 2 x 26 AWG, Triple Insulated Bias: 8T, 2 x 28 AWG
Winding Order (pin numbers)	Primary: 3-1, tape Secondary: 9,10-6,7, tape, Bias: 4-5, tape 3L
Primary Inductance	1059 μH ± 10%
Primary Resonant Frequency	0.75 MHz (Min)
Leakage Inductance	28 μH (Max)

Table 1. Transformer Construction Information.

THERMAL TEST RESULTS		
Thermal test load current is 1 A for 30 ms, 2.2 A for 10 ms		
Test Case	T (°C) @ 85 VAC	T (°C) @ 265 VAC
T1 (Transformer)	57	59
U1 (TOP245P)	64	51
D7 (Op Rectifier)	58	59
C8 (Op Capacitor)	41	40

Table 2. Thermal Test with Pulsed Load of Figure 3. 25 °C Ambient, Open Frame, 85 VAC and 265 VAC input.

For the latest updates, visit www.powerint.com

Power Integrations may make changes to its products at any time. Power Integrations has no liability arising from your use of any information, device or circuit described herein nor does it convey any license under its patent rights or the rights of others. POWER INTEGRATIONS MAKES NO WARRANTIES HEREIN AND SPECIFICALLY DISCLAIMS ALL WARRANTIES INCLUDING, WITHOUT LIMITATION, THE IMPLIED WARRANTIES OF MERCHANTABILITY, FITNESS FOR A PARTICULAR PURPOSE, AND NON-INFRINGEMENT OF THIRD PARTY RIGHTS. The products and applications illustrated herein (including circuits external to the products and transformer construction) may be covered by one or more U.S. and foreign patents or potentially by pending U.S. and foreign patent applications assigned to Power Integrations. A complete list of Power Integrations' patents may be found at www.powerint.com.

The PI logo, **TOPSwitch**, **TinySwitch**, **LinkSwitch** and **EcoSmart** are registered trademarks of Power Integrations. **PI Expert** and **DPA-Switch** are trademarks of Power Integrations. ©Copyright 2004, Power Integrations

Power Integrations		5245 Hellyer Avenue	San Jose, California 95138
MAIN PHONE NUMBER	APPLICATIONS HOTLINE	APPLICATIONS FAX	For a complete listing of worldwide sales offices, please visit www.powerint.com
+1 408-414-9200	+1 408-414-9660	+1 408-414-9760	

