



LXT908

Universal 3.3V 10BASE-T and AUI Transceiver

Datasheet

The LXT908 Universal 10BASE-T and AUI Transceiver is designed for IEEE 802.3 physical layer applications. It provides all the active circuitry to interface most standard 802.3 controllers to either the 10BASE-T media or Attachment Unit Interface (AUI). In addition to standard 10 Mbps Ethernet, the LXT908 also supports full-duplex operation at 20 Mbps.

LXT908 functions include Manchester encoding/decoding, receiver squelch and transmit pulse shaping, jabber, link testing and reversed polarity detection/correction. The LXT908 can be used to drive either the AUI drop cable or the 10BASE-T twisted-pair cable with only a simple isolation transformer. Integrated filters simplify the design work required for FCC-compliant EMI performance.

The LXT908 is fabricated with an advanced CMOS process and requires only a single 3.3V power supply.

Applications

- Access devices (DSL, Cable Modems, and Set-top Boxes)
- Routers/Bridges/Switches/Hubs
- Telecom Backplane
- USB to Ethernet Converters

Product Features

Functional Features

- Improved Filters - Simplifies FCC Compliance
- Integrated Manchester Encoder/Decoder
- 10BASE-T compliant Transceiver
- AUI Transceiver
- Supports Standard and Full-Duplex Ethernet

Diagnostic Features

- Four LED Drivers
- AUI/RJ-45 Loopback

Convenience Features

- Automatic/Manual AUI/RJ-45 Selection
- Automatic Polarity Correction
- SQE Disable/Enable function
- Power Down Mode with tri-stated outputs
- Four loopback modes
- Single 3.3V operation
- Available in 64-pin LQFP and 44-pin PLCC package
- Commercial (0 to +70°C) and Extended (-40 to +85°C) temperature range



Information in this document is provided in connection with Intel® products. No license, express or implied, by estoppel or otherwise, to any intellectual property rights is granted by this document. Except as provided in Intel's Terms and Conditions of Sale for such products, Intel assumes no liability whatsoever, and Intel disclaims any express or implied warranty, relating to sale and/or use of Intel products including liability or warranties relating to fitness for a particular purpose, merchantability, or infringement of any patent, copyright or other intellectual property right. Intel products are not intended for use in medical, life saving, or life sustaining applications.

Intel may make changes to specifications and product descriptions at any time, without notice.

Designers must not rely on the absence or characteristics of any features or instructions marked "reserved" or "undefined." Intel reserves these for future definition and shall have no responsibility whatsoever for conflicts or incompatibilities arising from future changes to them.

The LXT908 may contain design defects or errors known as errata which may cause the product to deviate from published specifications. Current characterized errata are available on request.

Contact your local Intel sales office or your distributor to obtain the latest specifications and before placing your product order.

Copies of documents which have an ordering number and are referenced in this document, or other Intel literature may be obtained by calling 1-800-548-4725 or by visiting Intel's website at <http://www.intel.com>.

Copyright © Intel Corporation, 2001

*Third-party brands and names are the property of their respective owners.

Contents

1.0	Pin Assignments and Signal Descriptions	8
2.0	Functional Description	11
2.1	Introduction.....	11
2.1.1	Controller Compatibility Modes	11
2.1.2	Transmit Function.....	12
2.1.3	Jabber Control Function	12
2.1.4	Receive Function.....	13
2.1.5	SQE Function	13
2.1.6	Polarity Reverse Function	14
2.1.7	Loopback Function	14
2.1.8	Collision Detection Function.....	15
2.1.9	Link Pulse Transmission	16
2.1.10	Link Integrity Test Function	16
3.0	Application Information	18
3.1	External Components.....	18
3.1.1	Crystal Information	18
3.1.2	Magnetic Information.....	18
3.2	Layout Requirements	18
3.2.1	Auto Port Select with External Loopback Control.....	18
3.2.2	Full Duplex Support.....	20
3.2.3	Dual Network Support-10Base T and Token Ring	21
3.2.4	Manual Port Select & Link Test Function	22
3.2.5	Three Media Application.....	24
3.2.6	AUI Encoder/Decoder Only	25
4.0	Test Specifications	26
4.1	Timing Diagrams for Mode 1 (MD2, 1, 0 = Low, Low, Low) Figures 16 - 21	30
4.2	Timing Diagrams for Mode 2 (MD2, 1, 0 = Low, Low, High) Figures 22 - 27	32
4.3	Timing Diagrams for Mode 3 (MD2, 1, 0 = Low, High, Low) Figures 28 - 33	34
4.4	Timing Diagrams for Mode 4 (MD2, 1, 0 = Low, High, High) Figures 34 - 39	36
4.5	Timing Diagrams for Mode 5 (MD2, 1, 0 = High, High, Low) Figures 40 - 45	38
5.0	Mechanical Specifications	40
A	Ordering Information	43

Figures

1	LXT908 Block Diagram	7
2	LXT908 Pin Assignments	8
3	LXT908 TPO Output Waveform	12
4	Jabber Control Function	13
5	SQE Function	14
6	Collision Detection Function	15
7	Transmitted Link Integrity Pulse Timing	16
8	Link Integrity Test Function	17
9	LAN Adapter Board - Auto Port Select with External Loopback Control	19
10	Full-Duplex Operation	20
11	LXT908/380C26 Interface for Dual Network Support of 10BASE-T and Token Ring	21
12	LAN Adapter Board - Manual Port Select with Link Test Function	22
13	Manual Port Select with Seeq 8005 Controller	23
14	Three Media Application	24
15	AUI Encoder/Decoder Only Application	25
16	Mode 1 RCLK/Start-of-Frame Timing	30
17	Mode 1 RCLK/End-of-Frame Timing	30
18	Mode 1 Transmit Timing	31
19	Mode 1 Collision Detect Timing	31
20	Mode 1 COL/SQE Output Timing/CI Output Timing	31
21	Mode 1 Loopback Timing	31
22	Mode 2 RCLK/Start-of-Frame Timing	32
23	Mode 2 RCLK/End-of-Frame Timing	32
24	Mode 2 Transmit Timing	33
25	Mode 2 Collision Detect Timing	33
26	Mode 2 COL/SQE Output Timing	33
27	Mode 2 Loopback Timing	33
28	Mode 3 RCLK/Start-of-Frame Timing	34
29	Mode 3 RCLK/End-of-Frame Timing	34
30	Mode 3 Transmit Timing	35
31	Mode 3 Collision Detect Timing	35
32	Mode 3 COL/SQE Output Timing	35
33	Mode 3 Loopback Timing	35
34	Mode 4 RCLK/Start-of-Frame Timing	36
35	Mode 4 RCLK/End-of-Frame Timing	36
36	Mode 4 Transmit Timing	37
37	Mode 4 Collision Detect Timing	37
38	Mode 4 COL/SQE Output Timing	37
39	Mode 4 Loopback Timing	37
40	Mode 5 RCLK/Start-of-Frame Timing	38
41	Mode 5 RCLK/End-of-Frame Timing	38
42	Mode 5 Transmit Timing	39
43	Mode 5 Collision Detect Timing	39
44	Mode 5 COL/SQE Output Timing	39
45	Mode 5 Loopback Timing	39
46	44-Pin PLCC Package Specifications	40
47	64-Pin LQFP Package Specifications	41
48	Ordering Information - Sample	43

Tables

1	LXT908 Signal Descriptions	9
2	Controller Compatibility Mode Options	12
3	Suitable Crystals	18
4	Absolute Maximum Values	26
5	Recommended Operating Conditions	26
6	I/O Electrical Characteristics	26
7	AUI Electrical Characteristics	27
8	Twisted-Pair Electrical Characteristics	27
9	Switching Characteristics	28
10	RCLK/Start-of-Frame Timing	28
11	RCLK/End-of-Frame Timing	29
12	Transmit Timing	29
13	Collision, COL/CI Output and Loopback Timing	29
14	Product Information	43

Revision History

Date	Revision	Page	Description
June 2001	2001	1	Added new set of applications
		19	Added 01. μ F label to capacitor at bottom of Figure 9
		20	Added 01. μ F label to capacitor at bottom of Figure 10
		21	Added 01. μ F label to capacitor at bottom of Figure 11
		22	Added 01. μ F label to capacitor at bottom of Figure 12
		23	Added 01. μ F label to capacitor at bottom of Figure 13
		26	Added second para. under "Test Specifications" regarding Quality and Reliability issues
		26	Removed "Ambient operating temperature" from Absolute Maximum Ratings table.
		43	Added Appendix: Product Ordering Information

Figure 1. LXT908 Block Diagram

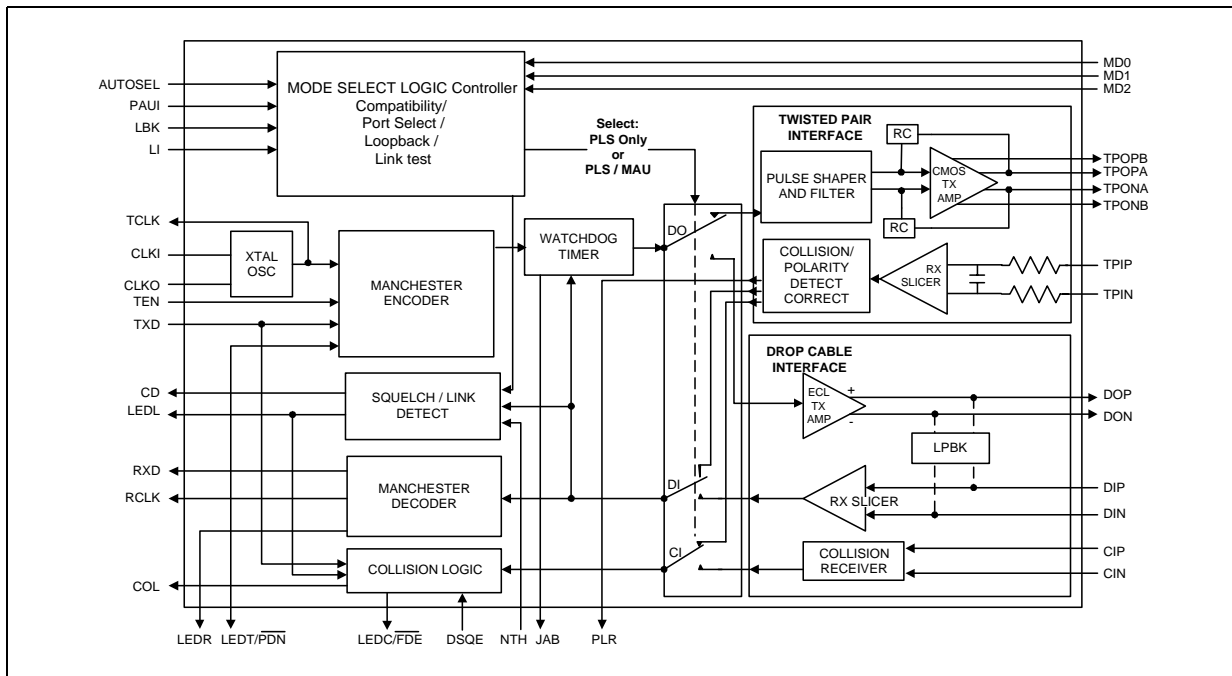

1.0 Pin Assignments and Signal Descriptions

Figure 2. LXT908 Pin Assignments

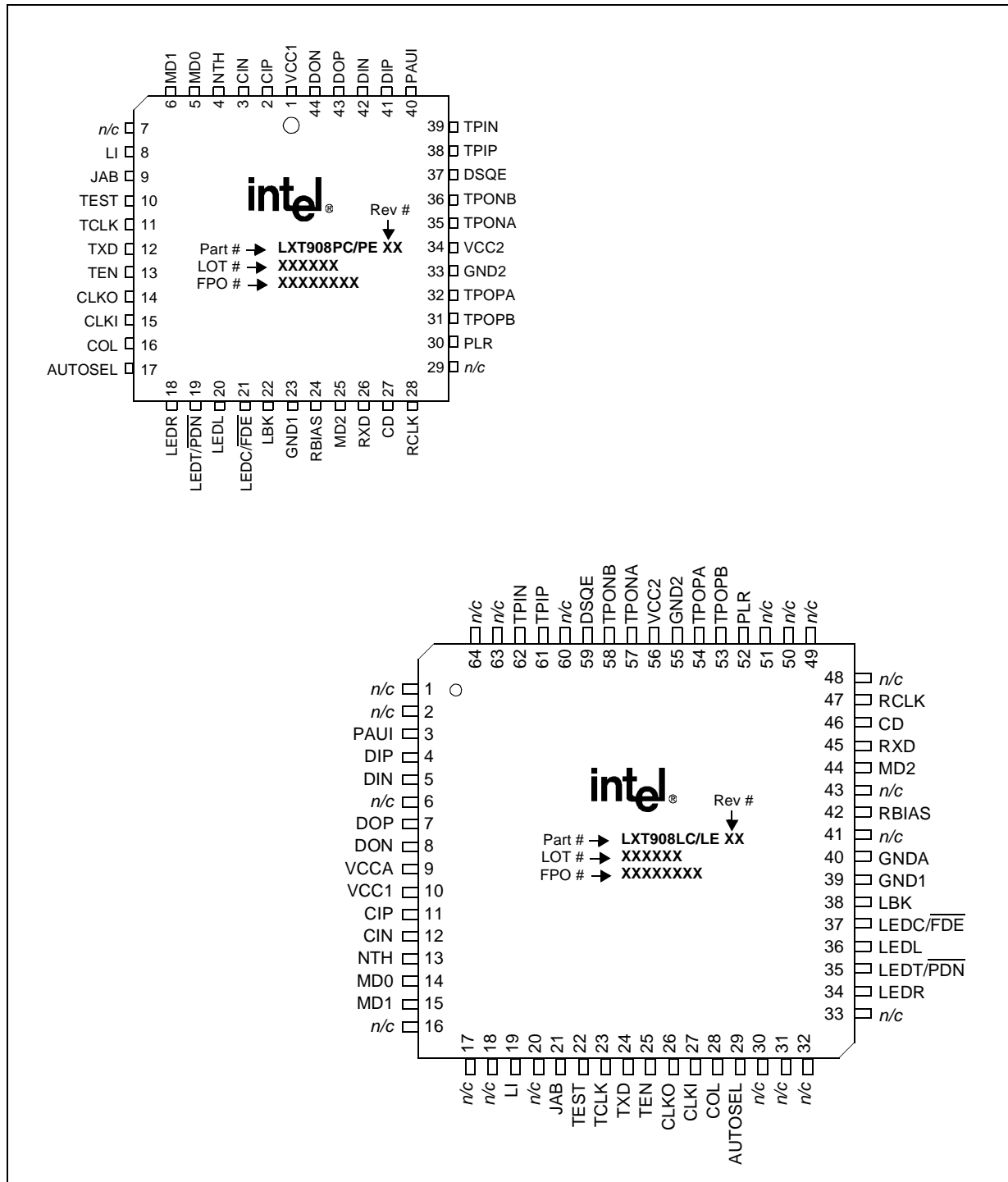

Table 1. LXT908 Signal Descriptions

Pin#		Symbol	I/O	Description
PLCC	LQFP			
1 34	10 56	VCC1 VCC2	– –	Power 1 and 2. Connect to positive power supply terminal (+3.3V DC).
–	9	VCCA	–	Analog Supply. (+3.3V)
2 3	11 12	CIP CIN	I I	AUI Collision Pair. Differential input pair connected to the AUI transceiver CI circuit. The input is collision signaling or SQE.
4	13	NTH	I	Normal Threshold. When NTH is High, the normal TP squelch threshold is in effect. When NTH is Low, the normal TP squelch threshold is reduced by 4.5 dB.
5 6 25	14 15 44	MD0 MD1 MD2	I I I	Mode Select 0 (MD0), Mode Select 1 (MD1) and Mode Select 2 (MD2). Mode select pins determine the controller compatibility mode as specified in Table 2 on page 12 .
7, 29	1, 2, 6, 16, 17, 18, 20, 30, 31, 32, 33, 41, 43, 48, 49, 50, 51, 60, 63, 64	N/C	–	No Connect. These pins may be left unconnected or tied to ground.
8	19	LI	I	Link Test Enable. Controls Link Integrity Test; enabled when High, disabled when Low.
9	21	JAB	O	Jabber Indicator. Output goes High to indicate Jabber state.
10	22	TEST	I	Test. This pin must be tied High.
11	23	TCLK	O	Transmit Clock. A 10 MHz clock output. This clock signal should be directly connected to the transmit clock input of the controller. TCLK goes to high impedance (tri-state) when LEDT/PDN is pulled Low externally.
12	24	TXD	I	Transmit Data. Input signal containing NRZ data to be transmitted on the network. TXD is connected directly to the transmit data output of the controller.
13	25	TEN	I	Transmit Enable. Enables data transmission and starts the Watch-Dog Timer. Synchronous to TCLK (see Test Specifications for details).
14 15	26 27	CLKO CLKI	O I	Crystal Oscillator. A 20 MHz crystal must be connected across these pins, or a 20 MHz clock applied at CLKI, with CLKO left open.
16	28	COL	O	Collision Detect. Output driving the collision detect input of the controller. COL goes to high impedance (tri-state) when LEDT/PDN is pulled Low externally.
17	29	AUTOSEL	I	Automatic Port Select. When High, automatic port selection is enabled (the LXT908 defaults to the AUI port only if TP link integrity = Fail). When Low, manual port selection is enabled (the PAUI pin determines the active port).
18	34	LEDR	O	Receive LED. Open drain driver for the receive indicator LED. Output is pulled Low during receive, except when data is being looped back to DIN/DIP from a remote transceiver (external MAU). LED "On" time (Low output) is extended by approximately 100 ms.

Table 1. LXT908 Signal Descriptions (Continued)

Pin#		Symbol	I/O	Description
PLCC	LQFP			
19	35	LEDT/ PDN	O I	Transmit LED (LEDT)/Power Down (PDN). Open drain driver for the transmit indicator LED. Output is pulled Low during transmit. Do not allow this pin to float. If unused, tie High. LED “On” time (Low output) is extended by approximately 100 ms. If externally tied Low, the LXT908 goes to power-down state. In power-down state, TCLK, COL, RXD, CD, and RCLK (pins 11, 16, 26, 27, and 28, respectively) are tri-stated.
20	36	LEDL	O I	Link LED. Open drain driver for link integrity indicator LED. Output is pulled Low during link test pass. If externally tied Low, internal circuitry is forced to “Link Pass” state and the LXT908 will continue to transmit link test pulses.
21	37	LEDC/ FDE	O I	Collision LED (LEDC)/Full Duplex Enable (FDE). Open drain driver for the collision indicator LED pulls Low during collision. LED “On” time (Low output) is extended by approximately 100 ms. If externally tied Low, the LXT908 disables the internal TP loopback and collision detection circuits to allow full-duplex operation or external twisted-pair loopback.
22	38	LBK	I	Loopback. Enables internal loopback mode. Refer to Functional Description and Test Specifications for details.
23 33	39 55	GND1 GND2	– –	Ground Returns 1 and 2. Connect to negative power supply terminal (ground).
–	40	GNDA	–	Analog Ground. Ground for analog plane.
24	42	RBIAS	I	Bias Control. A 12.4 k Ω 1% resistor to ground at this pin controls operating circuit bias.
26	45	RXD	O	Receive Data. Output signal connected directly to the receive data input of the controller. RXD goes to high impedance (tri-state) when LEDT/PDN is pulled Low externally.
27	46	CD	O	Carrier Detect. An output to notify the controller of activity on the network. CD goes to high impedance (tri-state) when LEDT/PDN is pulled Low externally.
28	47	RCLK	O	Receive Clock. A recovered 10 MHz clock that is synchronous to the received data and connected to the controller receive clock input. RCLK goes to high impedance (tri-state) when LEDT/PDN is pulled Low externally.
30	52	PLR	O	Polarity Reverse. Output goes High to indicate reversed polarity at the TP input.
32 35 31 36	54 57 53 58	TPOPA TPONA TPOPB TPONB	O O O O	Twisted-Pair Transmit Pairs A & B. Two differential driver pair outputs (A and B) to the twisted-pair cable. The outputs are pre-equalized. Each pair must be shorted together with an 11.5 Ω 1% resistor to match an impedance of 100 Ω .
37	59	DSQE	I	Disable SQE. When DSQE is High, the SQE function is disabled. When DSQE is Low, the SQE function is enabled. SQE must be disabled for normal operation in Hub/Switch applications.
3839	61 62	TPIP TPIN	I I	Twisted-Pair Receive Pair. A differential input pair from the TP cable. Receive filter is integrated on chip. No external filters are required.

Table 1. LXT908 Signal Descriptions (Continued)

Pin#		Symbol	I/O	Description
PLCC	LQFP			
40	3	PAUI	I	Port/AUI Select. In Manual Port Select mode (AUTOSEL Low), PAUI selects the active port. When PAUI is High, the AUI port is selected. When PAUI is Low, the TP port is selected. In Auto Port Select mode, PAUI must be tied to ground.
41 42	4 5	DIP DIN	I I	AUI Receive Pair. Differential input pair from the AUI transceiver DI circuit. The input is Manchester encoded.
43 44	7 8	DOP DON	O O	AUI Transmit Pair. A differential output driver pair for the AUI transceiver cable. The output is Manchester encoded.

2.0 Functional Description

2.1 Introduction

The LXT908 Universal 10BASE-T and AUI Transceiver performs the physical layer signaling (PLS) and Media Attachment Unit (MAU) functions as defined by the IEEE 802.3 specification. It functions as an AUI (PLS-Only device) for use with 10BASE-2 or 10BASE-5 coaxial cable networks, or as an Integrated PLS/MAU for use with 10BASE-T twisted-pair (TP) networks. In addition to standard 10 Mbps operation, the LXT908 also supports full-duplex 20 Mbps operation.

The LXT908 interfaces a back-end controller to either an AUI drop cable or a twisted-pair cable. The controller interface includes transmit and receive clock and NRZ data channels, as well as mode control logic and signaling. The AUI interface comprises three circuits: Data Output (DO), Data Input (DI), and Collision (CI). The twisted-pair interface comprises two circuits: Twisted-Pair Input (TPI) and Twisted-Pair Output (TPO). In addition to the three basic interfaces, the LXT908 contains an internal crystal oscillator and four LED drivers for visual status reporting.

Functions are defined from the back end controller side of the interface. The LXT908 Transmit function refers to data transmitted by the back end to the AUI cable (PLS-Only mode) or to the twisted-pair network (Integrated PLS/MAU mode). The LXT908 Receive function refers to data received by the back end from the AUI cable (PLS-Only) or from the twisted-pair network (Integrated PLS/MAU mode). In the integrated PLS/MAU mode, the LXT908 performs all required MAU functions defined by the IEEE 802.3 10BASE-T specification, such as collision detection, link integrity testing, signal quality error messaging, jabber control, and loopback. In the PLS-Only mode, the LXT908 receives incoming signals from the AUI DI circuit with ± 18 ns of jitter and drives the AUI DO circuit.

2.1.1 Controller Compatibility Modes

The LXT908 is compatible with most industry-standard controllers including devices produced by Advanced Micro Devices (AMD), Motorola, Intel, Fujitsu, National Semiconductor, Seeq, and Texas Instruments, as well as custom controllers. Five different control signal timing and polarity schemes (Modes 1 through 5) are required to achieve this compatibility. Mode select pins (MD2:0) determine Controller compatibility modes as listed in [Table 2 on page 12](#). Refer to Test Specifications for a complete set of timing diagrams for each mode.

2.1.2 Transmit Function

The LXT908 receives NRZ data from the controller at the TXD input as shown in [Figure 1](#), “LXT908 Block Diagram” on [page 7](#), and passes it through a Manchester encoder. The encoded data is then transferred to either the AUI cable (the DO circuit) or the twisted-pair network (the TPO circuit). The advanced integrated pulse shaping and filtering network produces the output signal on TPON and TPOP, shown in [Figure 3](#). The TPO output is pre-distorted and pre-filtered to meet the 10BASE-T jitter template. An internal continuous resistor-capacitor filter is used to remove any high-frequency clocking noise from the pulse shaping circuitry. Integrated filters simplify the design work required for FCC-compliant EMI performance. During idle periods, the LXT908 transmits link integrity test pulses on the TPO circuit (if LI is enabled and integrated PLS/MAU mode is selected). External resistors control the termination impedance.

Figure 3. LXT908 TPO Output Waveform

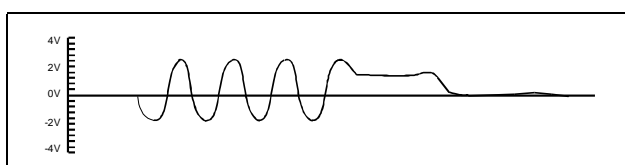
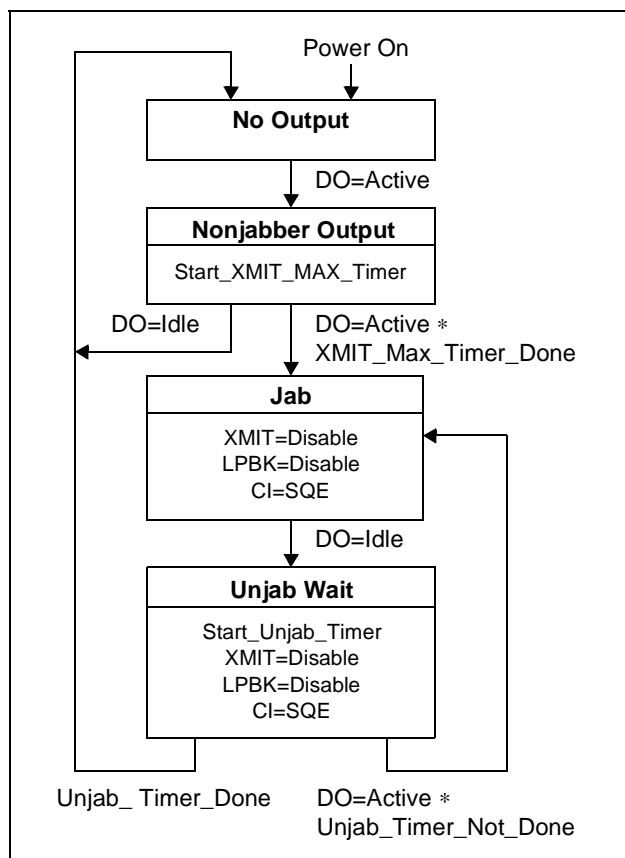

Table 2. Controller Compatibility Mode Options

Controller Mode	MD2	MD1	MD0
Mode 1 - For AMD AM7990, Motorola 68EN360, MPC860 or compatible controllers	Low	Low	Low
Mode 2 - For Intel 82596 or compatible controllers	Low	Low	High
Mode 3 - For Fujitsu MB86950, MB86960 or compatible controllers (Seeq 8005) ¹	Low	High	Low
Mode 4 - For National Semiconductor 8390 or compatible controllers (TI TMS380C26)	Low	High	High
Mode 5 - For custom controllers (Mode 3 with TCLK, RCLK and COL inverted)	High	High	Low
1. SEEQ controllers require inverters on CLKI, LBK, RCLK, and COL in Mode 3; or on CLKI, LBK, and TCLK in Mode 5.			

2.1.3 Jabber Control Function

[Figure 4](#) on [page 13](#) is a state diagram of the LXT908 Jabber control function. The LXT908 on-chip Watch-Dog Timer prevents the DTE from locking into a continuous transmit mode. When a transmission exceeds the time limit, the Watch-Dog Timer disables the transmit and loopback functions, and activates the JAB pin. Once the LXT908 is in the jabber state, the TXD circuit must remain idle for a period of 0.25 to 0.75 seconds before it will exit the jabber state.

Figure 4. Jabber Control Function

2.1.4 Receive Function

The LXT908 receive function acquires timing and data from the twisted-pair network (TPI circuit) or from the AUI (DI circuit). Valid received signals are passed through the on-chip filters and Manchester decoder then output as decoded NRZ data and recovered clock on the RXD and RCLK pins, respectively.

An internal RC filter and an intelligent squelch function discriminate noise from link test pulses and valid data streams. The receive function is activated only by valid data streams above the squelch level and with proper timing. If the differential signal at the TPI or the DI circuit inputs falls below 75 percent of the threshold level (unsquelched) for 8 bit times (typical), the LXT908 receive function enters the idle state. If the polarity of the TPI circuit is reversed, LXT908 detects the polarity reverse and reports it via the PLR output. The LXT908 automatically corrects reversed polarity.

2.1.5 SQE Function

In the integrated PLS/MAU mode, the LXT908 supports the signal quality error (SQE) function as shown in [Figure 5 on page 14](#), although the SQE function can be disabled. After every successful transmission on the 10BASE-T network when SQE is enabled, the LXT908 transmits the SQE signal for $10\text{BT} \pm 5\text{BT}$ over the internal CI circuit, which is indicated on the COL pin of the device.

SQE must be disabled for normal operation in hub and switch applications. In twisted-pair applications, the SQE function is disabled when DSQE is set High, and enabled when DSQE is Low. When using the 10BASE-2 port of the LXT908, the SQE function is determined by the external MAU attached.

Figure 5. SQE Function

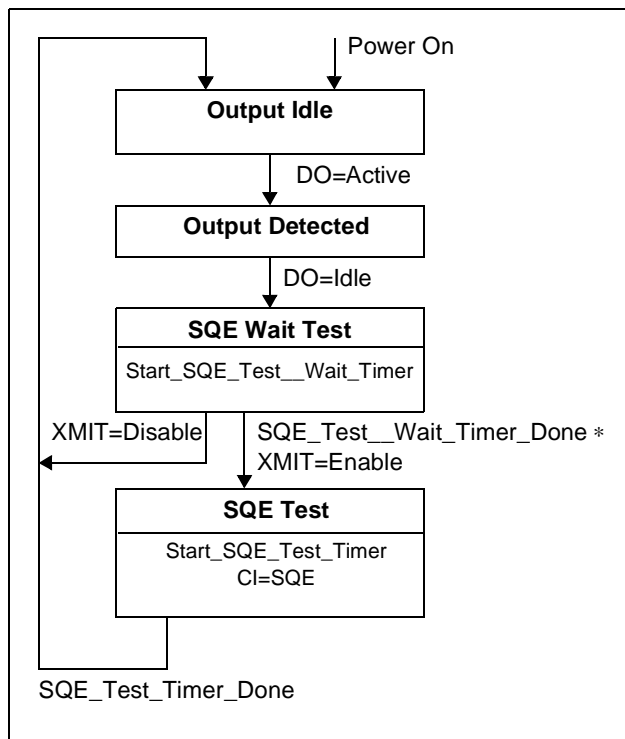

2.1.6 Polarity Reverse Function

The LXT908 polarity reverse function uses both link pulses and end-of-frame data to determine polarity of the received signal. A reversed polarity condition is detected when eight opposite receive link pulses are detected without receipt of a link pulse of the expected polarity. Reversed polarity is also detected if four frames are received with a reversed start-of-idle. Whenever a correct polarity frame or a correct link pulse is received, these two counters are reset to zero. If the LXT908 enters the link fail state and no valid data or link pulses are received within 96 to 128 ms, the polarity is reset to the default non-flipped condition. If Link Integrity Testing is disabled, polarity detection is based only on received data. Polarity correction is always enabled.

2.1.7 Loopback Function

The LXT908 provides the normal loopback function specified by the 10BASE-T standard for the twisted-pair port. The loopback function operates in conjunction with the transmit function. Data transmitted by the back-end is internally looped back within the LXT908 from the TXD pin through the Manchester encoder/decoder to the RXD pin and returned to the back-end. This “normal” loopback function is disabled when a data collision occurs, clearing the RXD circuit for the TPI data. Normal loopback is also disabled during link fail and jabber states.

The LXT908 also provides three additional loopback functions. An external loopback mode, useful for system-level testing, is controlled by pin 21 (LEDC). When LEDC is tied Low, the LXT908 disables the collision detection and internal loopback circuits, to allow external loopback or full-duplex operation.

“Normal” twisted-pair loopback is controlled by pin 22 (LBK). When the twisted-pair port is selected and LBK is High, twisted-pair loopback is “forced”, overriding collisions on the twisted-pair circuit. When LBK is Low, normal loopback is in effect.

AUI loopback is also controlled by the LBK pin. When the AUI port is selected and LBK is High, data transmitted by the back-end is internally looped back from the TXD pin through the Manchester encoder/decoder to the RXD pin. When LBK is Low, no AUI loopback occurs.

2.1.8 Collision Detection Function

The collision detection function operates on the twisted-pair side of the interface. For standard (half-duplex) 10BASE-T operation, a collision is defined as the simultaneous presence of valid signals on both the TPI circuit and the TPO circuit. The LXT908 reports collisions to the back-end via the COL pin. If the TPI circuit becomes active while there is activity on the TPO circuit, the TPI data is passed to the back-end over the RXD circuit, disabling normal loopback. Figure 6 is a state diagram of the LXT908 collision detection function. Refer to Test Specifications for collision detection and COL/CI output timing.

Note: For full-duplex operation, the collision detection circuitry must be disabled.

Figure 6. Collision Detection Function

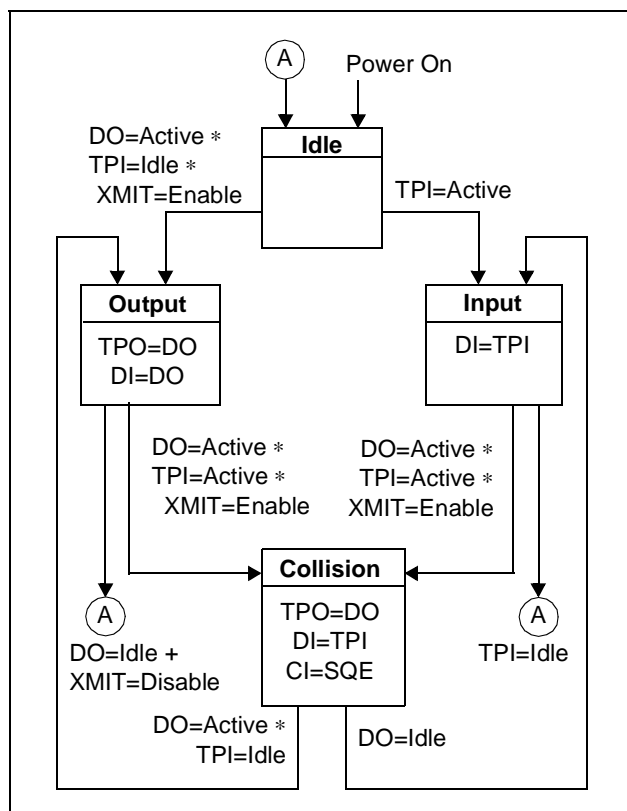

2.1.9 Link Pulse Transmission

The LXT908 transmits standard link pulses which meet the 10BASE-T specifications. Figure 7 shows the link integrity pulse timing.

Figure 7. Transmitted Link Integrity Pulse Timing

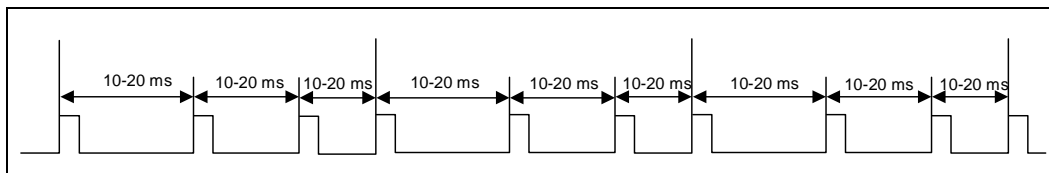

2.1.10 Link Integrity Test Function

Figure 8 on page 17 is a state diagram of the LXT908 Link Integrity test function. The link integrity test is used to determine the status of the receive side twisted-pair cable. Link integrity testing is enabled when pin 8 (LI) is tied High. When enabled, the receiver recognizes link integrity pulses which are transmitted in the absence of receive traffic.

If no serial data stream or link integrity pulses are detected within 50 - 150 ms, the chip enters a link fail state and disables the transmit and normal loopback functions. The LXT908 ignores any link integrity pulse with interval less than 2 - 7 ms. The LXT908 will remain in the link fail state until it detects either a serial data packet or two or more link integrity pulses.

Figure 8. Link Integrity Test Function

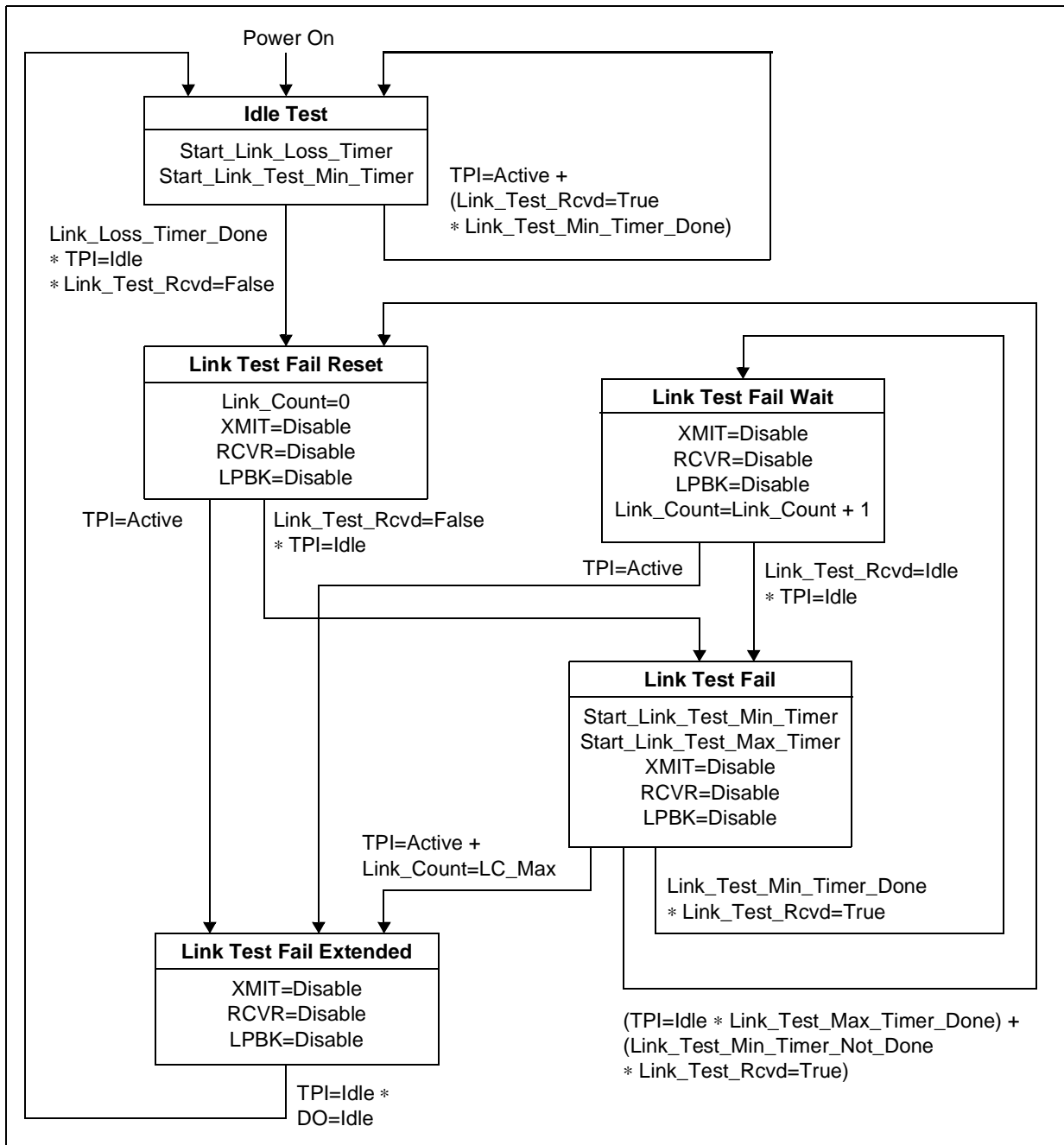

3.0 Application Information

Figure 9 on page 19 through Figure 15 on page 25 show typical LXT908 applications.

3.1 External Components

3.1.1 Crystal Information

Suitable crystals are available from various manufacturers. Table 3 lists suitable crystals based on a limited evaluation. Designers should test and validate all crystals before using them in production.

Table 3. Suitable Crystals

Manufacturer	Part Number
MTRON	MP-1
	MP-2

3.1.2 Magnetic Information

The twisted-pair interface requires a 1:1 ratio for the receive transformer, and a 1:2 ratio for the transmit transformer. The AUI interface requires a 1:1 ratio for data-in, data-out, and collision-pair transformers. A cross-reference list of suitable magnetics and part numbers is available in Application Note 73, Magnetic Manufacturers (248991-001), that can be found on the Intel website (www.intel.com). Designers should test and validate all magnetics before committing to a specific component.

3.2 Layout Requirements

3.2.1 Auto Port Select with External Loopback Control

Figure 9 on page 19 is a typical LXT908 application. The diagram groups similar pins together, but does not represent the actual LXT908 pin-out. The controller interface pins (TXD, RXD, TEN, TCLK, RCLK, CD, COL, and LBK) are shown at the top left of the diagram.

Programmable option pins are grouped at the center left of the diagram. The PAUI pin is tied Low and all other option pins are tied High. This setup selects the following options:

- Automatic Port Selection (PAUI Low and AUTOSEL High)
- Normal Receive Threshold (NTH High)
- Mode 4, compatible with National NS8390 controllers (MD2:0 = Low, High, High)
- SQE Disabled (DSQE High)
- Link Testing Enabled (LI High)

Status outputs are grouped at the lower left of the diagram. Line status outputs drive LED indicators and the Jabber and Polarity status indicators are available, as required.

Power and ground pins are shown at the bottom of the diagram. A single-power supply is used for both VCC1 and VCC2, with a decoupling capacitor installed between the power and ground busses.

An additional power and ground pin (VCCA and GNDA) is supported in designs using the 64-pin LQFP package. A single-power supply is used for all three power and ground pins (VCC1, VCC2, VCCA) and (GND1, GND2, GNDA). Please install a decoupling capacitor between each power and ground buss.

The twisted-pair and AUI interfaces are shown at the upper and lower right of the diagram, respectively. Impedance matching resistors for 100 UTP are installed in each I/O pair, but no external filters are required.

Figure 9. LAN Adapter Board - Auto Port Select with External Loopback Control

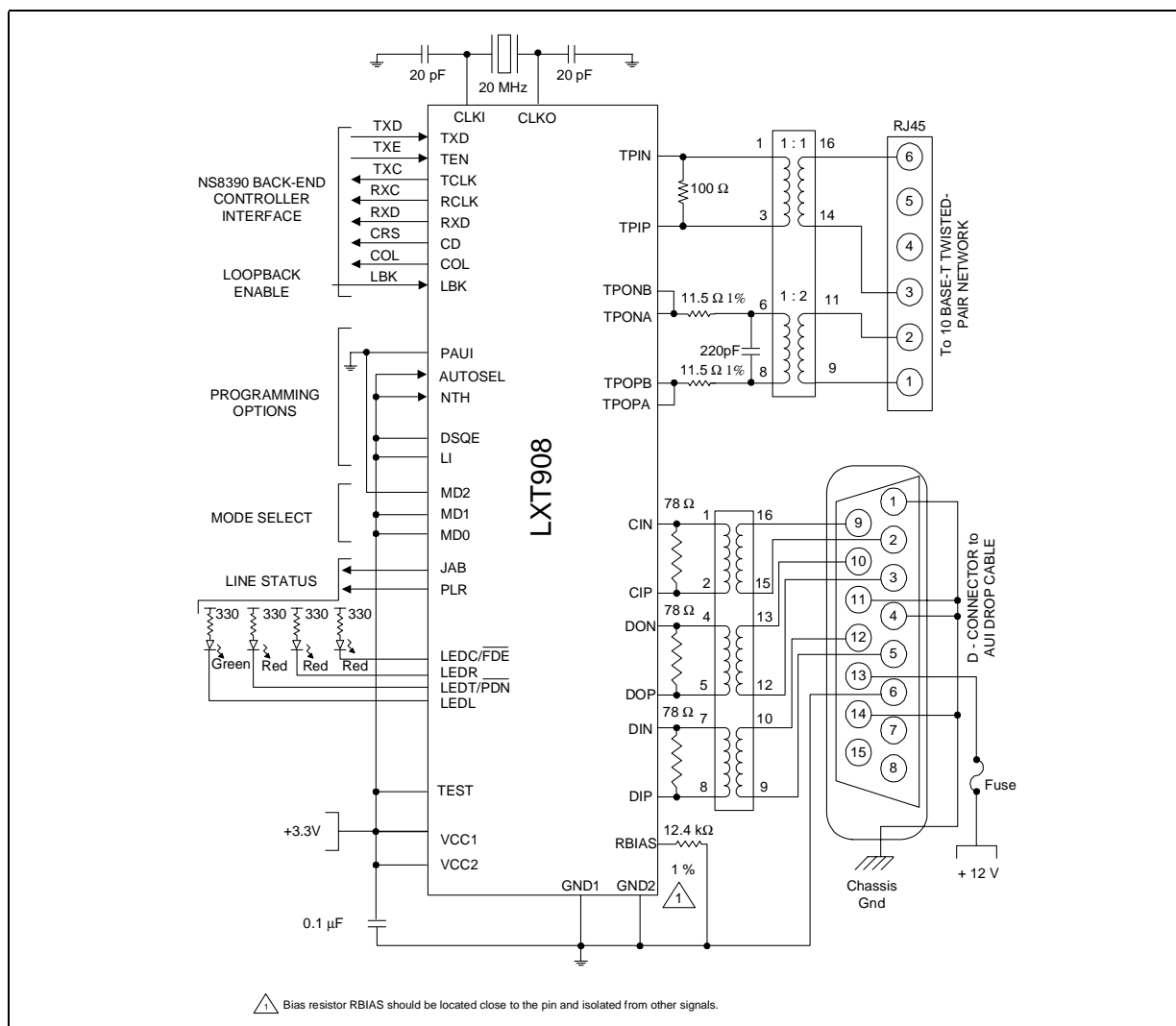

3.2.2 Full Duplex Support

Figure 10 shows the LXT908 with a Texas Instruments 380C24 CommProcessor. The 380C24 is compatible with Mode 4 (MD2:0 = Low, High, High). When used with the 380C24 or other full-duplex-capable controllers, the LXT908 supports full-duplex Ethernet, effectively doubling the available bandwidth of the network. In this application, the SQE function is enabled (DSQE tied Low), and the LXT908 AUI port is not used.

Figure 10. Full-Duplex Operation

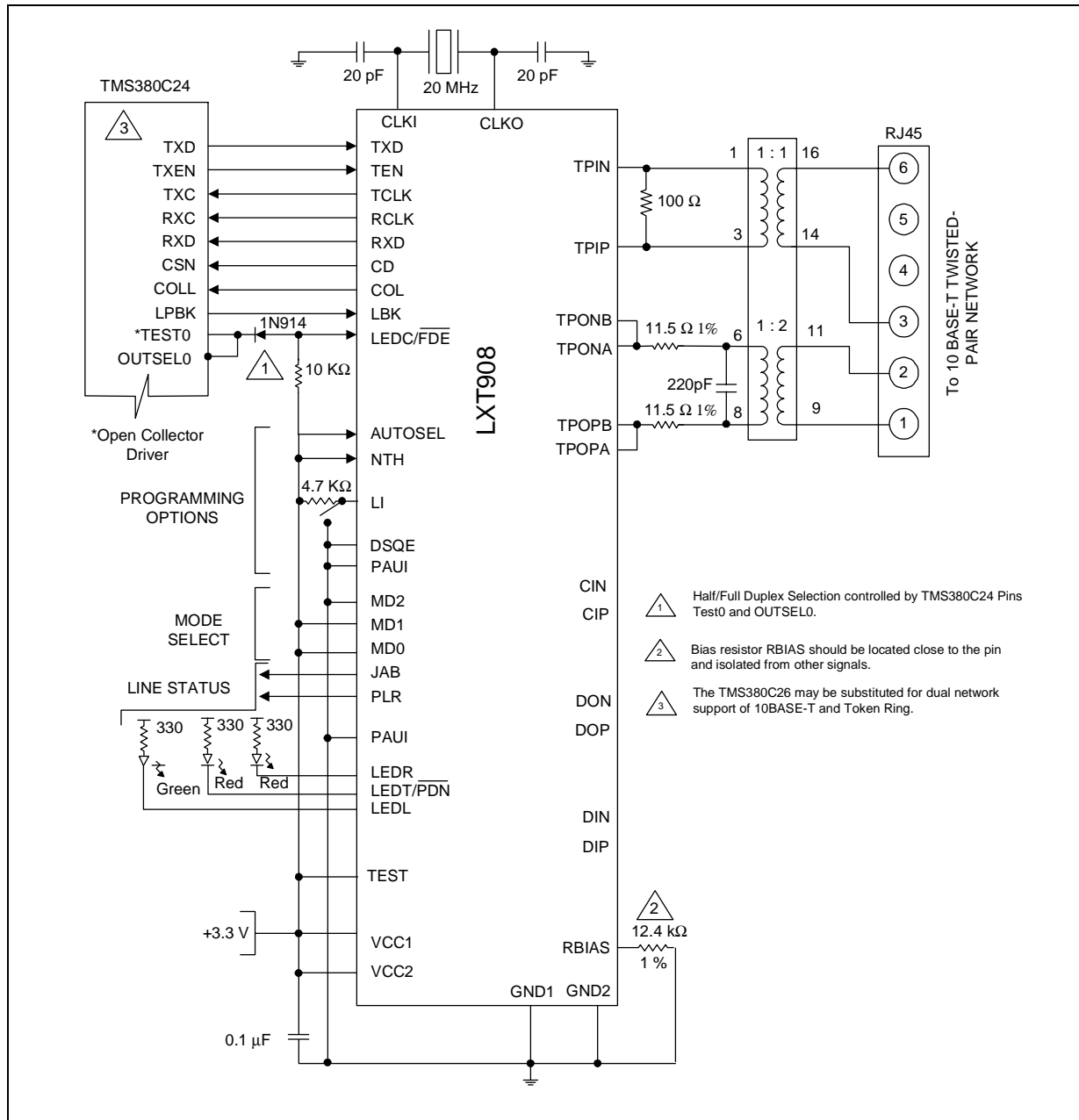

3.2.4 Manual Port Select & Link Test Function

When MD2:0 = Low, High, Low, the LXT908 logic and framing are set to Mode 3 (compatible with Fujitsu MB86950 and MB86960, and Seeq 8005 controllers). Figure 12 shows the setup for Fujitsu controllers. Figure 13 on page 23 shows the four inverters required to interface with the Seeq 8005 controller. As in Figure 9 on page 19, both these Mode 3 applications show the LI pin tied High, enabling Link Testing; and the NTH and DSQE pins are both tied High, selecting the standard receiver threshold and disabling SQE. However, in these applications, AUTOSEL is tied Low, allowing external port selection through the PAUI pin.

Figure 12. LAN Adapter Board - Manual Port Select with Link Test Function

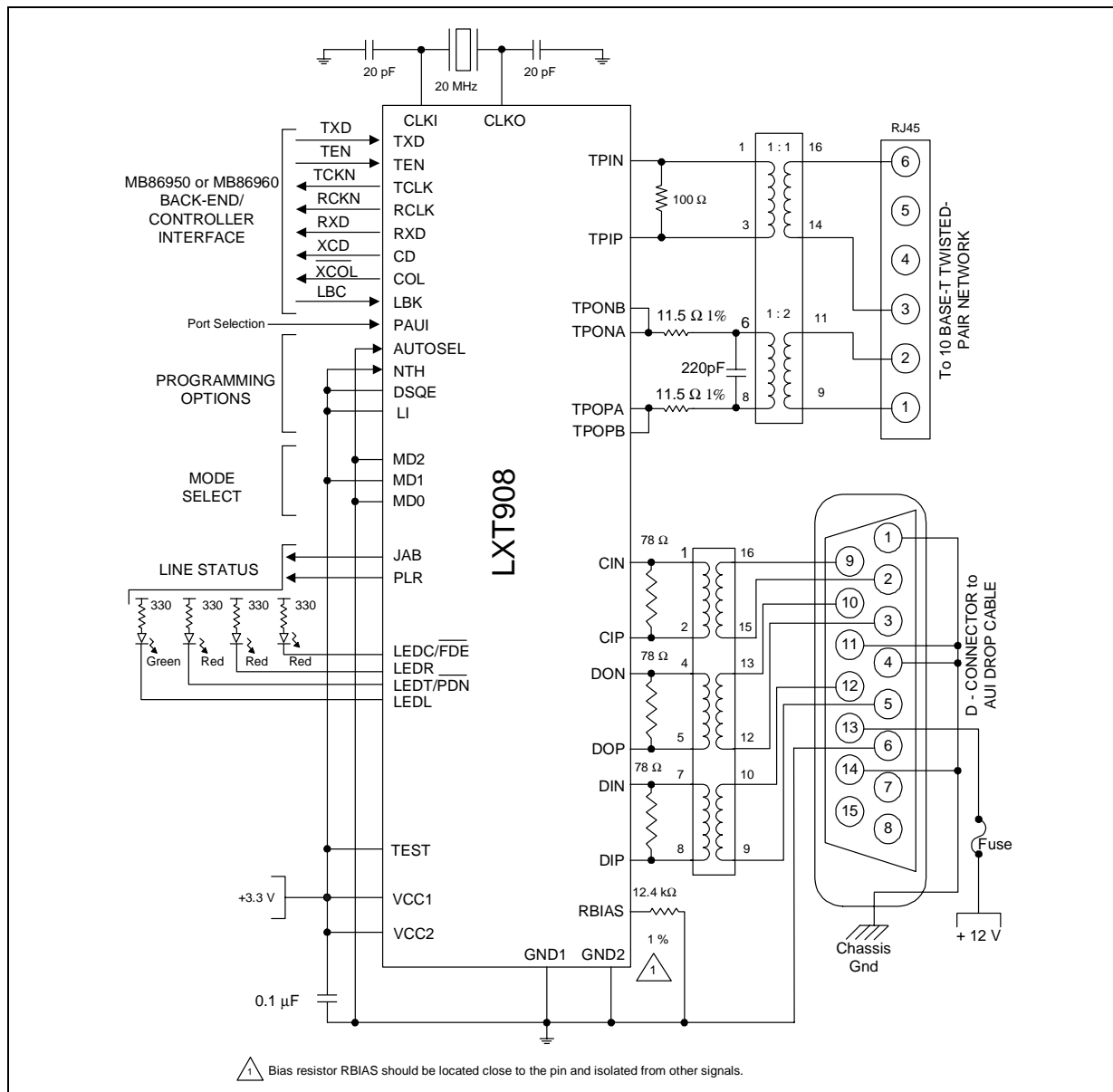
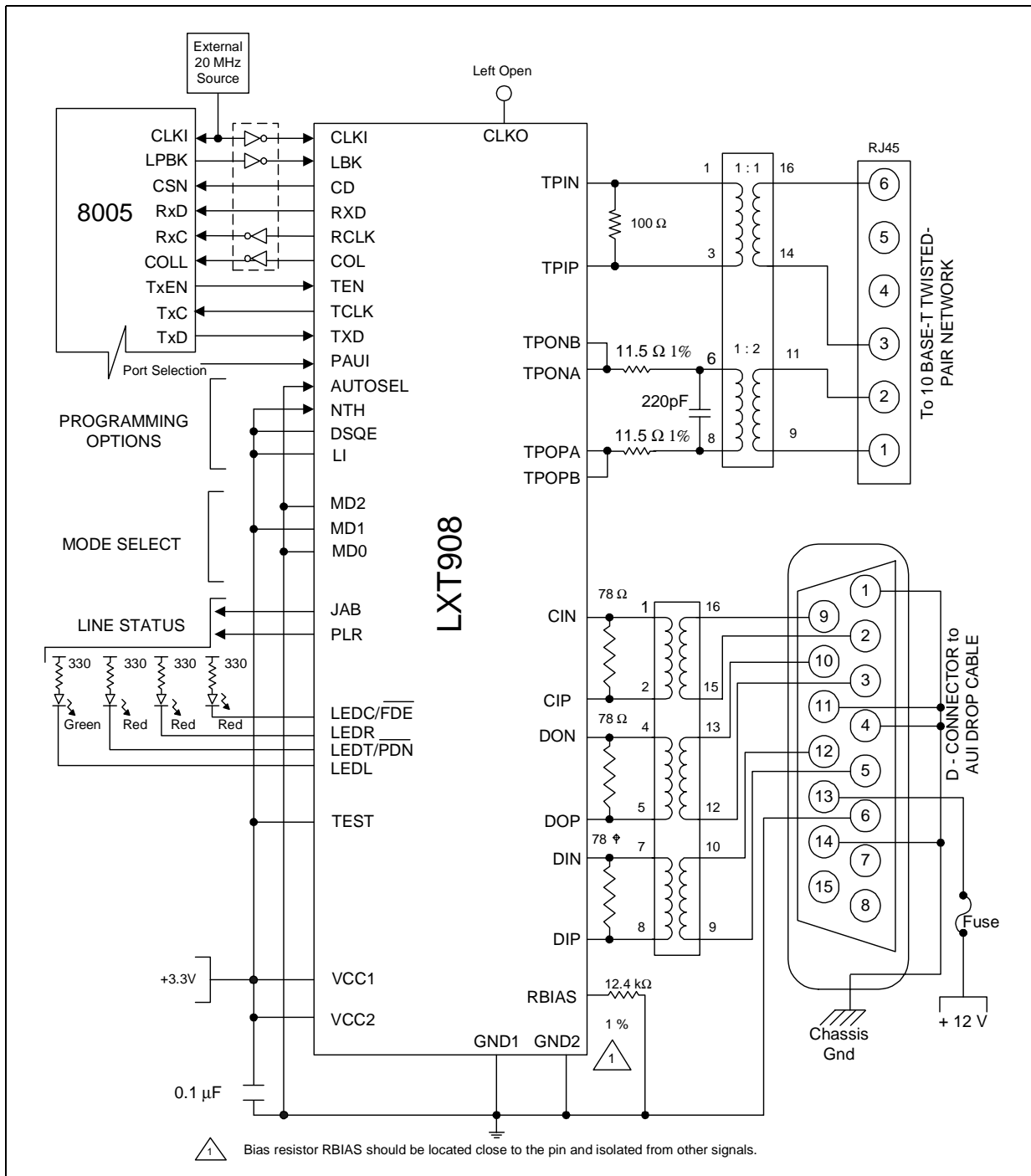

Figure 13. Manual Port Select with Seeq 8005 Controller



3.2.6 AUI Encoder/Decoder Only

In the application shown in Figure 15, the DTE is connected to a coaxial network through the AUI. AUTOSEL is tied Low and PAUI is tied High, manually selecting the AUI port. The twisted-pair port is not used. With MD2:0 all tied Low, the LXT908 logic and framing are set to Mode 1 (compatible with AMD and Motorola controllers). The LI pin is tied Low, disabling the link test function. The DSQE pin is also Low, enabling the SQE function. The LBK input controls loopback. A 20 MHz system clock is supplied at CLKI, with CLKO left open.

Figure 15. AUI Encoder/Decoder Only Application

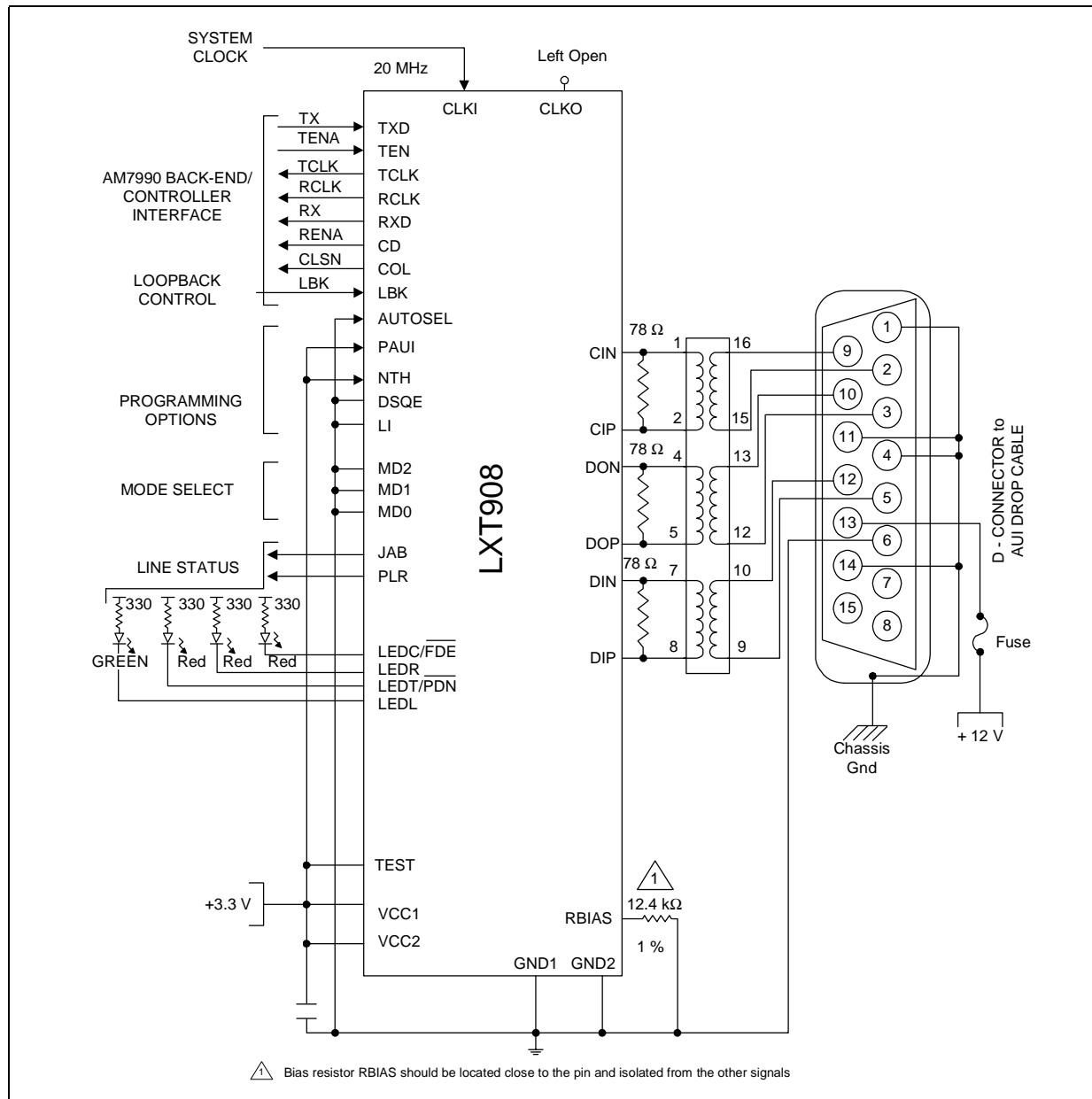

4.0 Test Specifications

Note: Table 4 through Table 13 on page 29 and Figure 16 on page 30 through Figure 45 on page 39 represent the performance specifications of the LXT908. These specifications are guaranteed by test except where noted “by design.” Minimum and maximum values listed in Table 6 through Table 13 on page 29 apply over the recommended operating conditions specified in Table 5.

For all Quality and Reliability issues (for example, parts packaging and thermal specifications), please send your questions to Intel at the following e-mail address: www.qr.requests@intel.com.

Table 4. Absolute Maximum Values

Parameter	Symbol	Min	Max	Units
Supply voltage	VCC	-0.3	6	V
Storage temperature	TSTG	-65	+150	°C
Caution: Exceeding these values may cause permanent damage. Functional operation under these conditions is not implied. Exposure to maximum rating conditions for extended periods may affect device reliability.				

Table 5. Recommended Operating Conditions

Parameter	Symbol	Min	Typ	Max	Units
Recommended supply voltage ¹	VCC	3.13	3.3	3.47	V
Recommended operating temperature (Commercial)	TOP	0	–	+70	°C
Recommended operating temperature (Extended)	TOP	-40	–	+85	°C
1. Voltages with respect to ground unless otherwise specified.					

Table 6. I/O Electrical Characteristics

Parameter	Sym	Min	Typ ¹	Max	Units	Test Conditions
Input Low voltage ²	VIL	–	–	0.8	V	
Input High voltage ²	VIH	2.0	–	–	V	
Output Low voltage	VOL	–	–	0.4	V	IOL = 1.6 mA
	VOL	–	–	10	%VCC	IOL < 10 μA
Output Low voltage (Open drain LED driver)	VOLL	–	–	0.7	V	IOLL = 10 mA
Output High voltage	VOH	2.4	–	–	V	IOH = 40 μA
	VOH	90	–	–	%VCC	IOH < 10 μA
Output rise time TCLK & RCLK	CMOS	–	–	3	12	ns CLOAD = 20 pF
	TTL	–	–	2	8	ns
1. Typical values are at 25°C and are for design aid only, are not guaranteed, and are not subject to production testing. 2. Limited functional tests are performed at these input levels. The majority of functional tests are performed at levels of 0V and 3V.						

Table 6. I/O Electrical Characteristics (Continued)

Parameter		Sym	Min	Typ ¹	Max	Units	Test Conditions
Output fall time TCLK & RCLK	CMOS	–	–	3	12	ns	CLOAD= 20 pF
	TTL	–	–	2	8	ns	
CLKI rise time (externally driven)		–	–	–	10	ns	
CLKI duty cycle (externally driven)		–	–		40/60	%	
Supply current	Normal Mode	I _{CC}	–	65	85	mA	Idle Mode
		I _{CC}	–	95	120	mA	Transmitting on TP
		I _{CC}	–	90	120	mA	Transmitting on AUI
	Power Down Mode	I _{CC}	–	0.75	2	mA	

1. Typical values are at 25°C and are for design aid only, are not guaranteed, and are not subject to production testing.
 2. Limited functional tests are performed at these input levels. The majority of functional tests are performed at levels of 0V and 3V.

Table 7. AUI Electrical Characteristics

Parameter	Symbol	Min	Typ ¹	Max	Units	Test Conditions
Input Low current	I _{IL}	–	–	-700	μA	–
Input High current	I _{IH}	–	–	500	μA	–
Differential output voltage	V _{OD}	±550	–	±1200	mV	–
Differential squelch threshold	V _{DS}	150	260	350	mV	5 MHz square wave input

1. Typical values are at 25°C and are for design aid only, are not guaranteed, and are not subject to production testing.

Table 8. Twisted-Pair Electrical Characteristics

Parameter	Symbol	Min	Typ ¹	Max	Units	Test Conditions
Transmit output impedance	Z _{OUT}	–	5	–	Ω	
Transmit timing jitter addition ²	–	–	±6.4	±10	ns	0 line length for internal MAU
Transmit timing jitter added by the MAU and PLS sections ^{2, 3}	–	–	±3.5	±5.5	ns	After line model specified by IEEE 802.3 for 10BASE-T internal MAU

1. Typical values are at 25°C and are for design aid only, are not guaranteed, and are not subject to production testing.
 2. Parameter is guaranteed by design; not subject to production testing.
 3. IEEE 802.3 specifies maximum jitter additions at 1.5 ns for the AUI cable, 0.5 ns from the encoder, and 3.5 ns from the MAU.

Table 8. Twisted-Pair Electrical Characteristics (Continued)

Parameter		Symbol	Min	Typ ¹	Max	Units	Test Conditions
Receive input impedance		Z _{IN}	–	20	–	kΩ	Between TPIP/TPIN, CIP/CIN & DIP/DIN
Differential Squelch Threshold	Normal Threshold NTH = High	V _{DS}	300	395	585	mV	5 MHz square wave input
	Reduced Threshold NTH = Low	V _{DS}	180	250	345	mV	5 MHz square wave input
1. Typical values are at 25°C and are for design aid only, are not guaranteed, and are not subject to production testing. 2. Parameter is guaranteed by design; not subject to production testing. 3. IEEE 802.3 specifies maximum jitter additions at 1.5 ns for the AUI cable, 0.5 ns from the encoder, and 3.5 ns from the MAU.							

Table 9. Switching Characteristics

Parameter		Symbol	Minimum	Typical ¹	Maximum	Units
Jabber Timing	Maximum transmit time	–	20	–	150	ms
	Unjab time	–	250	–	750	ms
Link Integrity Timing	Time link loss receive	–	50	–	150	ms
	Link min receive	–	2	–	7	ms
	Link max receive	–	50	–	150	ms
	Link transmit period	–	8	10/20	24	ms
1. Typical values are at 25°C and are for design aid only, are not guaranteed, and are not subject to production testing.						

Table 10. RCLK/Start-of-Frame Timing

Parameter		Symbol	Minimum	Typical ¹	Maximum	Units
Decoder acquisition time	AUI	t _{DATA}	–	900	1100	ns
	TP	t _{DATA}	–	1200	1500	ns
CD turn-on delay	AUI	t _{CD}	–	25	200	ns
	TP	t _{CD}	–	420	550	ns
Receive data setup from RCLK	Mode 1	tr _{DS}	60	70	–	ns
	Modes 2 through 5	tr _{DS}	30	45	–	ns
Receive data hold from RCLK	Mode 1	tr _{DH}	10	20	–	ns
	Modes 2 through 5	tr _{DH}	30	45	–	ns
RCLK shut off delay from CD assert (Mode 3 and Mode 5)		ts _{WS}	–	±100	–	ns
1. Typical values are at 25°C and are for design aid only, are not guaranteed, and are not subject to production testing.						

Table 11. RCLK/End-of-Frame Timing

Parameter	Type	Sym	Mode 1	Mode 2	Mode 3	Mode 4	Mode 5	Units
RCLK after CD off	Min	tRC	5	1	–	5	–	BT
RXD throughput delay	Max	tRD	400	375	375	375	375	ns
CD turn off delay ²	Max	tCDOFF	500	475	475	475	475	ns
Receive block out after TEN off	Typ ¹	tIFG	5	50	–	–	–	BT
RCLK switching delay after CD off (Mode 3 and 5)	Typ ¹	tsWE	–	–	120(±80)	–	120(±80)	ns
1. Typical values are at 25°C and are for design aid only, are not guaranteed, and are not subject to production testing. 2. CD turn-off delay measured from middle of last bit: timing specification is unaffected by the value of the last bit.								

Table 12. Transmit Timing

Parameter	Symbol	Minimum	Typical ¹	Maximum	Units
TEN setup from TCLK	tEHCH	22	–	–	ns
TXD setup from TCLK	tDSCH	22	–	–	ns
TEN hold after TCLK	tCHEL	5	–	–	ns
TXD hold after TCLK	tCHDU	5	–	–	ns
Transmit start-up delay - AUI	tSTUD	–	220	450	ns
Transmit start-up delay - TP	tSTUD	–	430	450	ns
Transmit through-put delay - AUI	tTPD	–	–	300	ns
Transmit through-put delay - TP	tTPD	–	305	350	ns
1. Typical values are at 25°C and are for design aid only, are not guaranteed, and are not subject to production testing.					

Table 13. Collision, COL/CI Output and Loopback Timing

Parameter	Symbol	Minimum	Typical ¹	Maximum	Units
COL turn-on delay	tCOLD	–	40	500	ns
COL turn-off delay	tCOLOFF	–	420	500	ns
COL (SQE) Delay after TEN off	tsQED	0.65	1.2	1.6	µs
COL (SQE) Pulse Duration	tsQEP	500	1000	1500	ns
LBK setup from TEN	tKHEH	10	25	–	ns
LBK hold after TEN	tKHEL	10	0	–	ns
1. Typical values are at 25°C and are for design aid only, are not guaranteed, and are not subject to production testing.					

4.1 Timing Diagrams for Mode 1 (MD2, 1, 0 = Low, Low, Low) Figures 16 - 21

Figure 16. Mode 1 RCLK/Start-of-Frame Timing

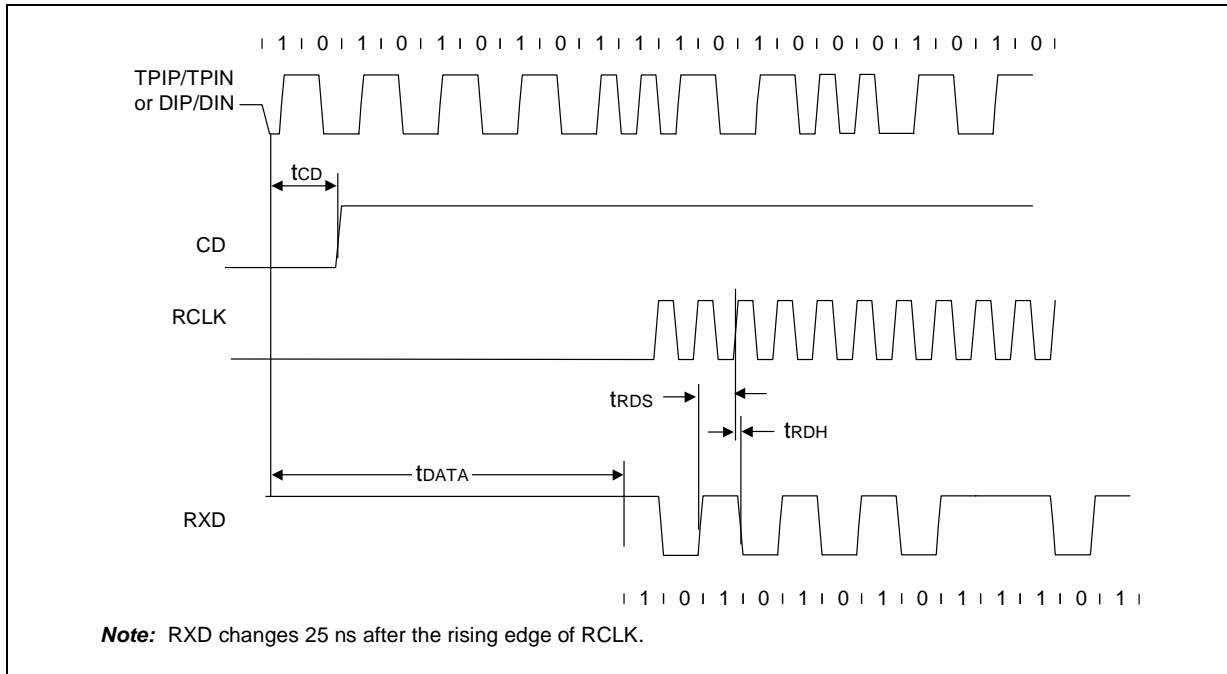

Figure 17. Mode 1 RCLK/End-of-Frame Timing

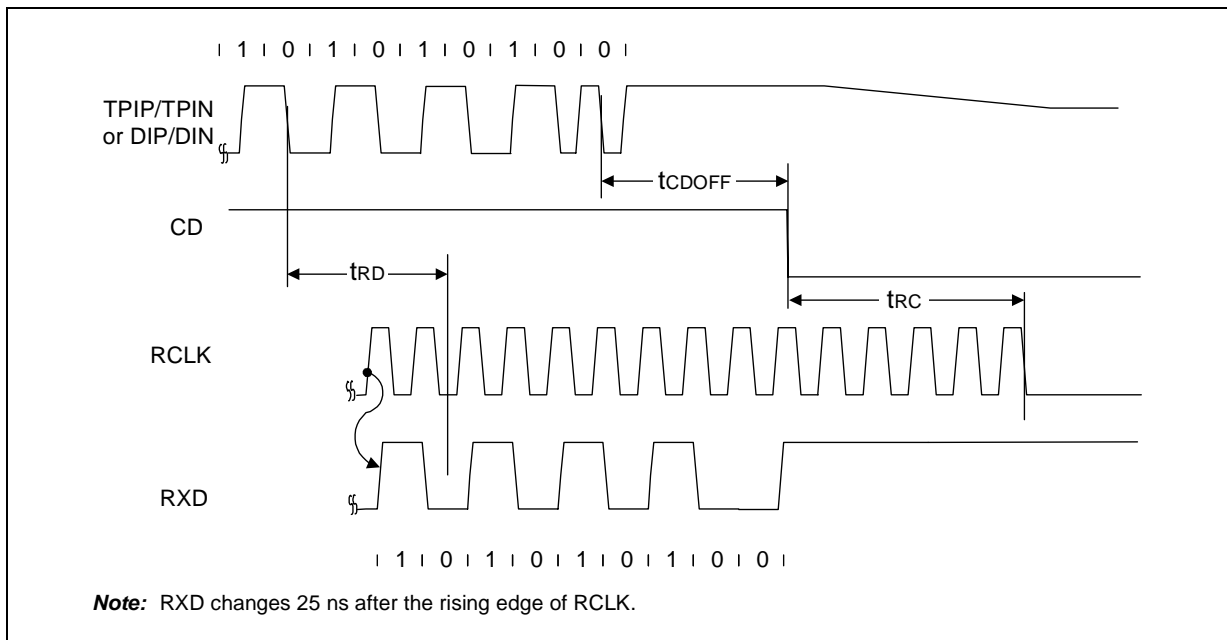

Figure 18. Mode 1 Transmit Timing

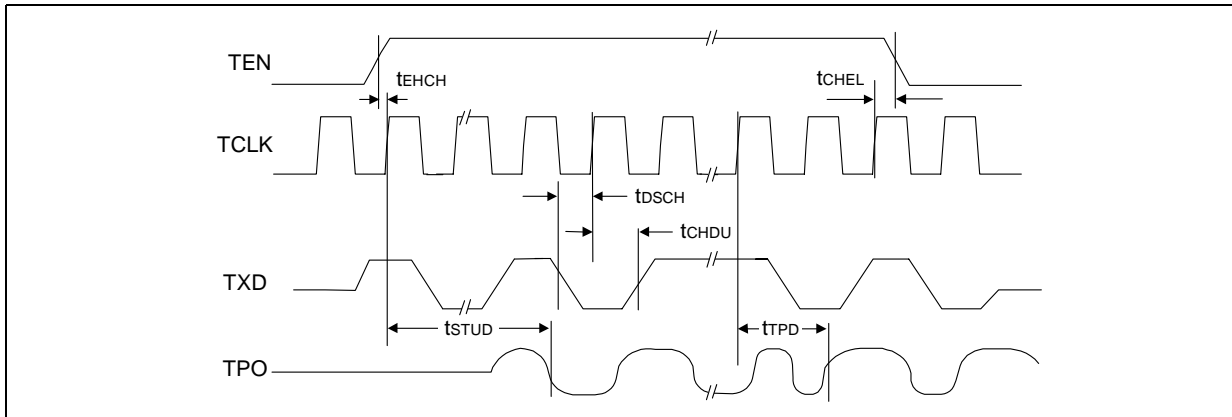

Figure 19. Mode 1 Collision Detect Timing

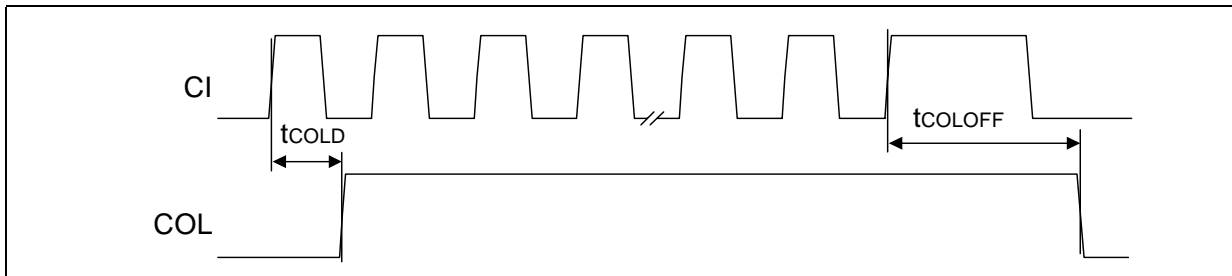

Figure 20. Mode 1 COL/SQE Output Timing/CI Output Timing

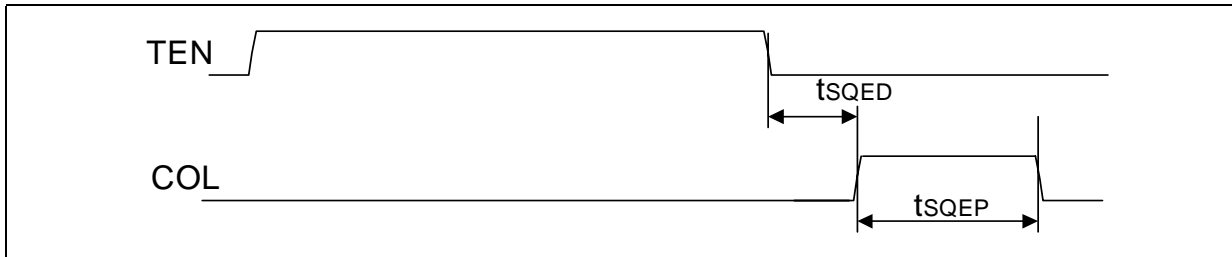
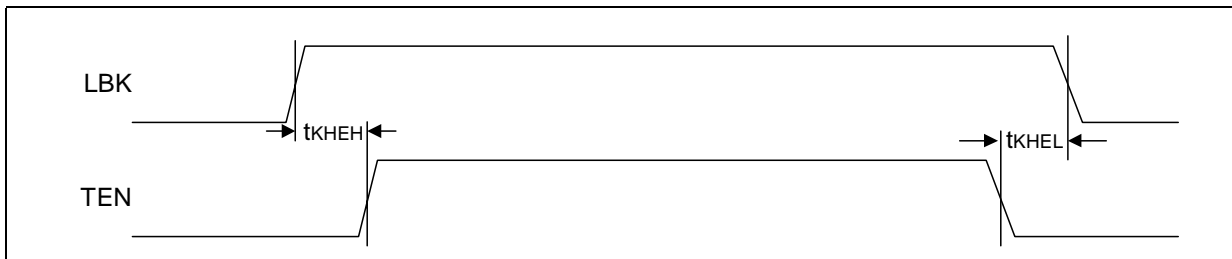

Figure 21. Mode 1 Loopback Timing



4.2 Timing Diagrams for Mode 2 (MD2, 1, 0 = Low, Low, High) Figures 22 - 27

Figure 22. Mode 2 RCLK/Start-of-Frame Timing

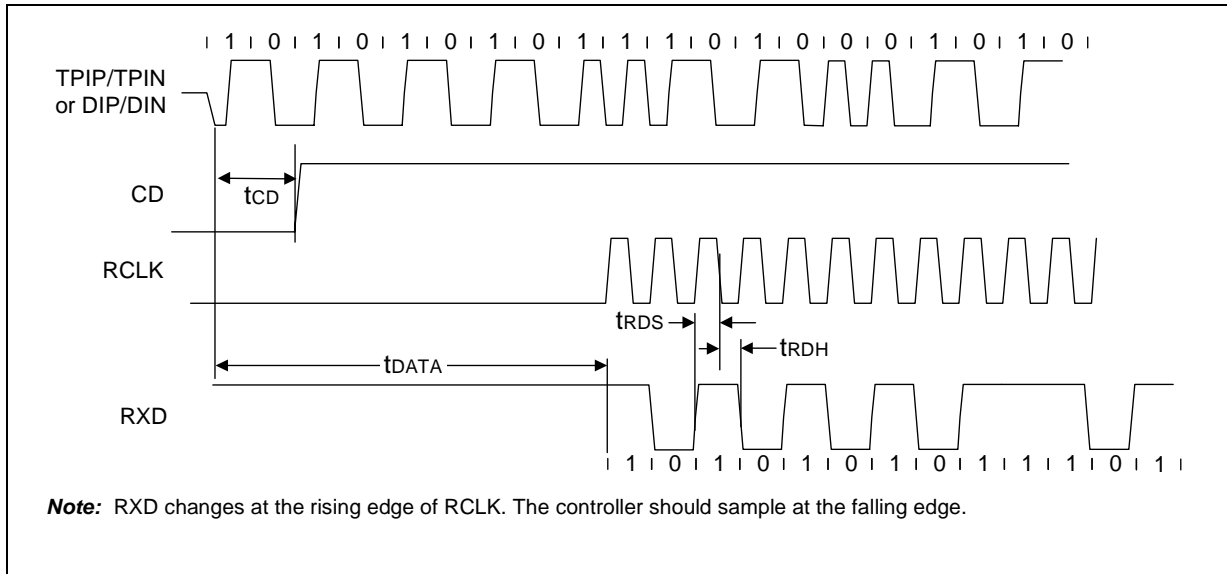

Figure 23. Mode 2 RCLK/End-of-Frame Timing

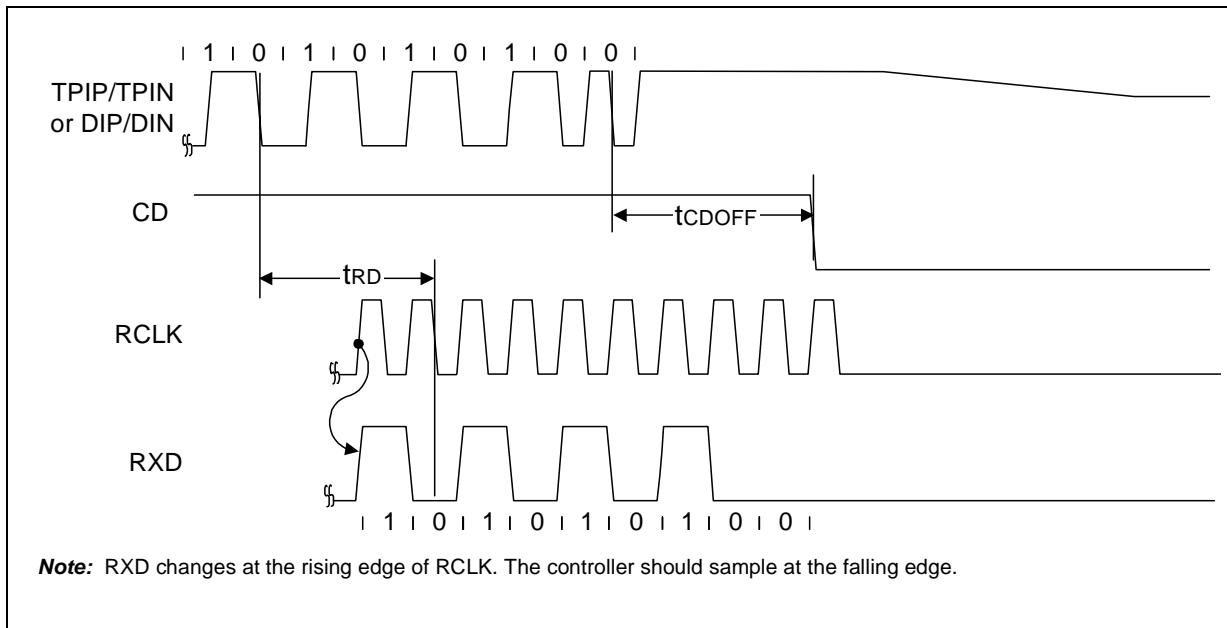

Figure 24. Mode 2 Transmit Timing

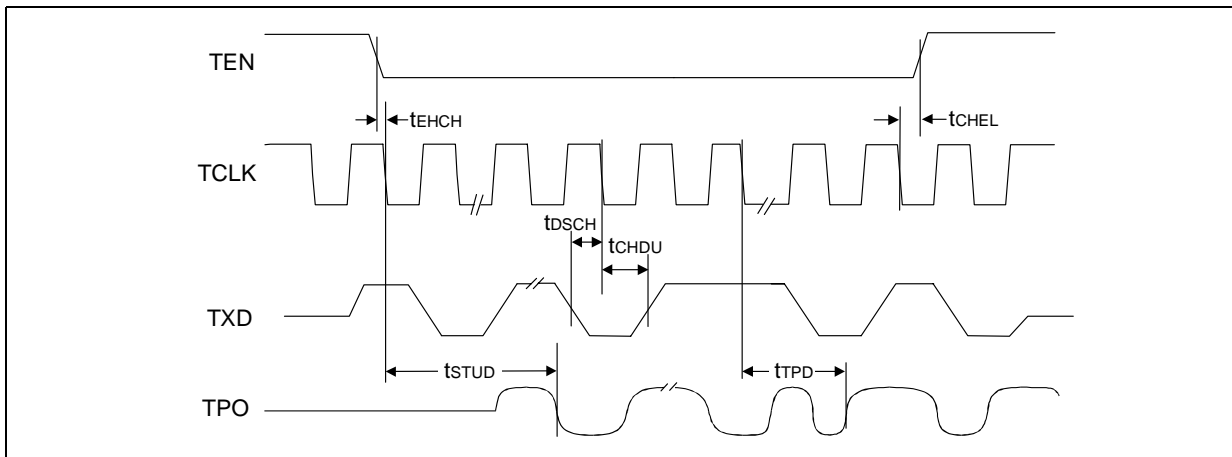

Figure 25. Mode 2 Collision Detect Timing

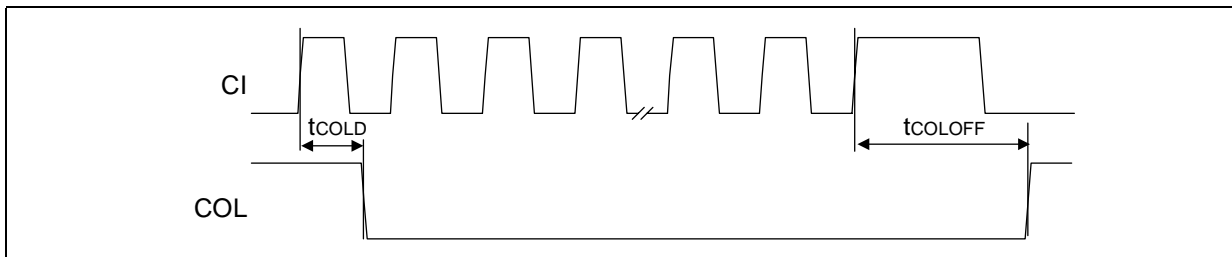

Figure 26. Mode 2 COL/SQE Output Timing

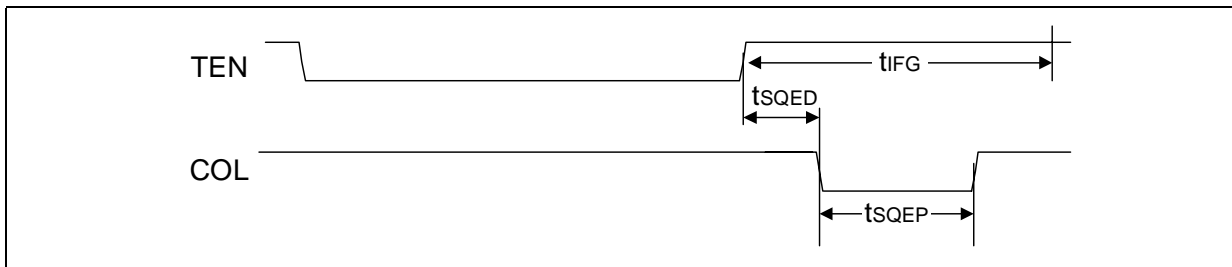
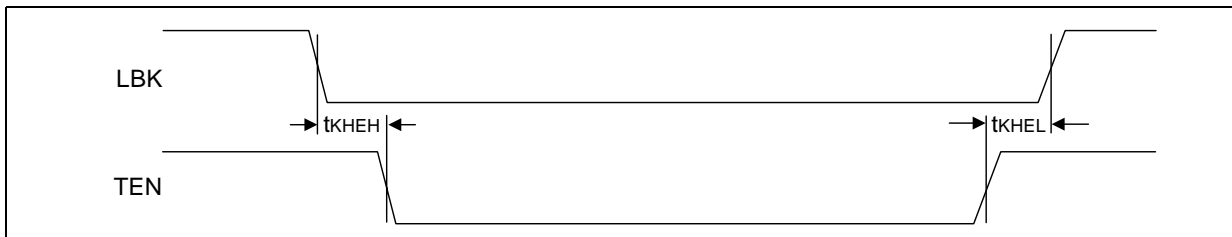

Figure 27. Mode 2 Loopback Timing



4.3 Timing Diagrams for Mode 3 (MD2, 1, 0 = Low, High, Low) Figures 28 - 33

Figure 28. Mode 3 RCLK/Start-of-Frame Timing

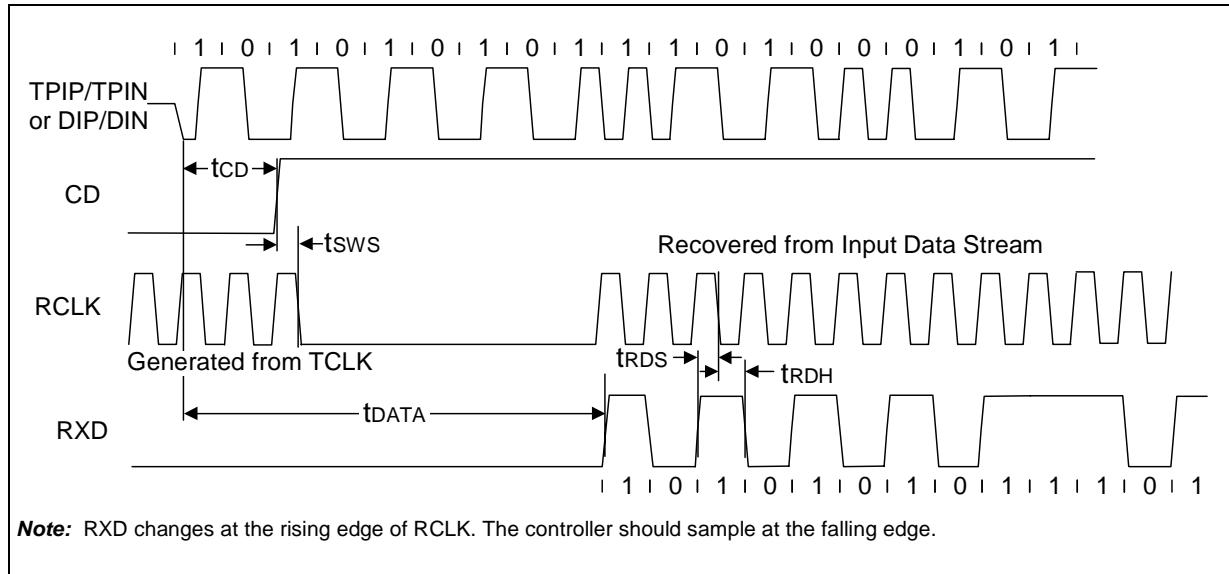

Figure 29. Mode 3 RCLK/End-of-Frame Timing

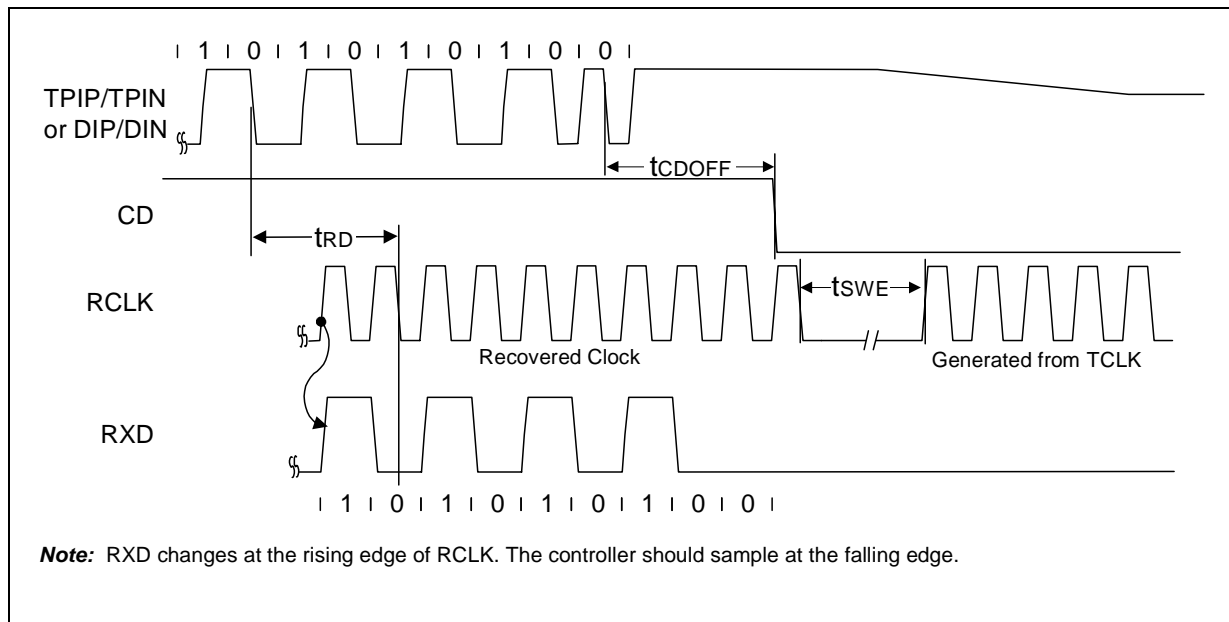

Figure 30. Mode 3 Transmit Timing

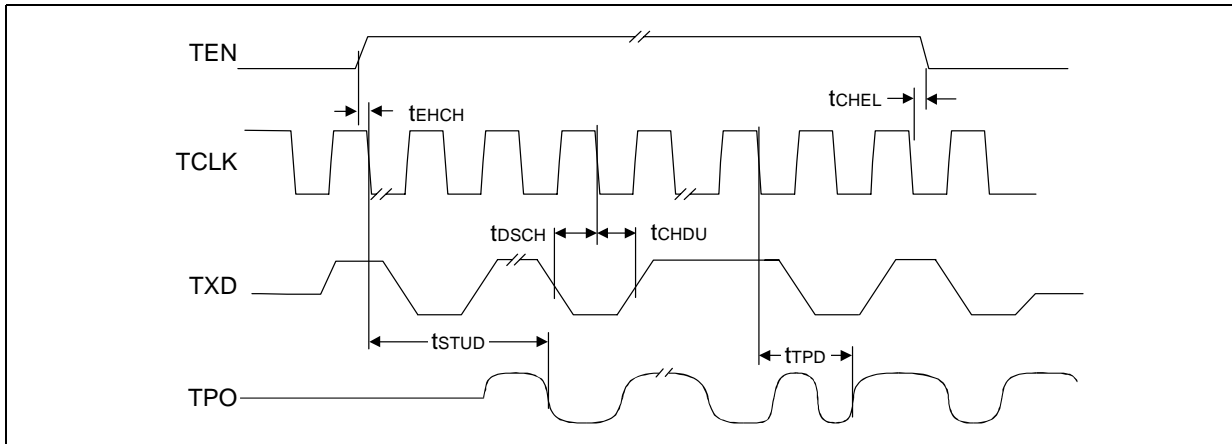

Figure 31. Mode 3 Collision Detect Timing

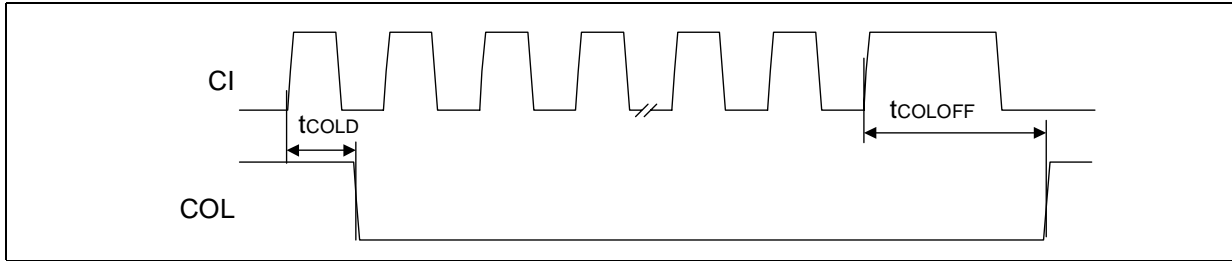

Figure 32. Mode 3 COL/SQE Output Timing

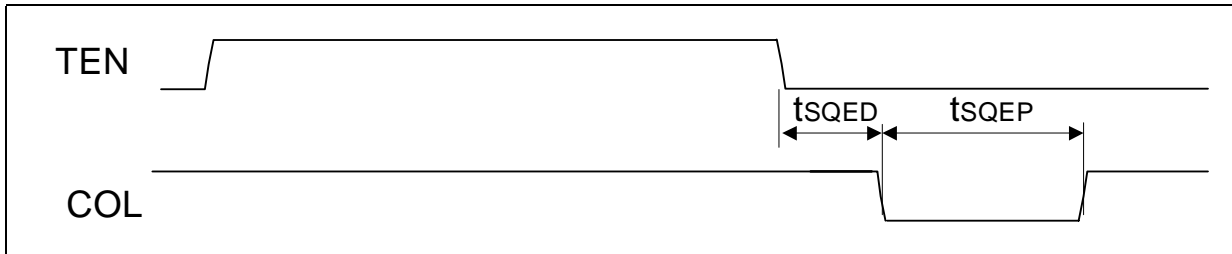
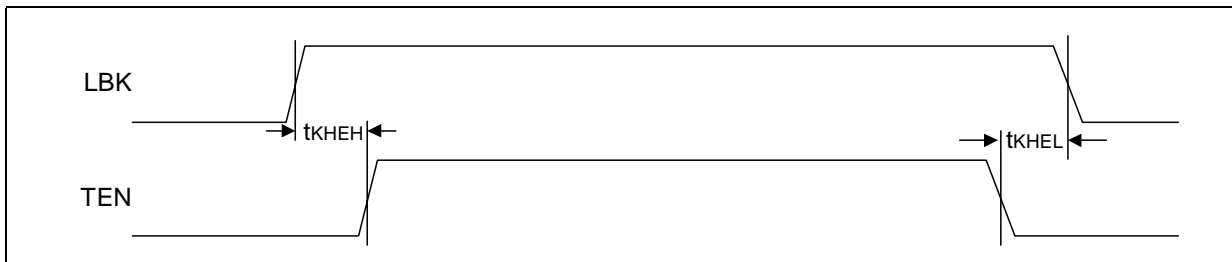

Figure 33. Mode 3 Loopback Timing



4.4 Timing Diagrams for Mode 4 (MD2, 1, 0 = Low, High, High) Figures 34 - 39

Figure 34. Mode 4 RCLK/Start-of-Frame Timing

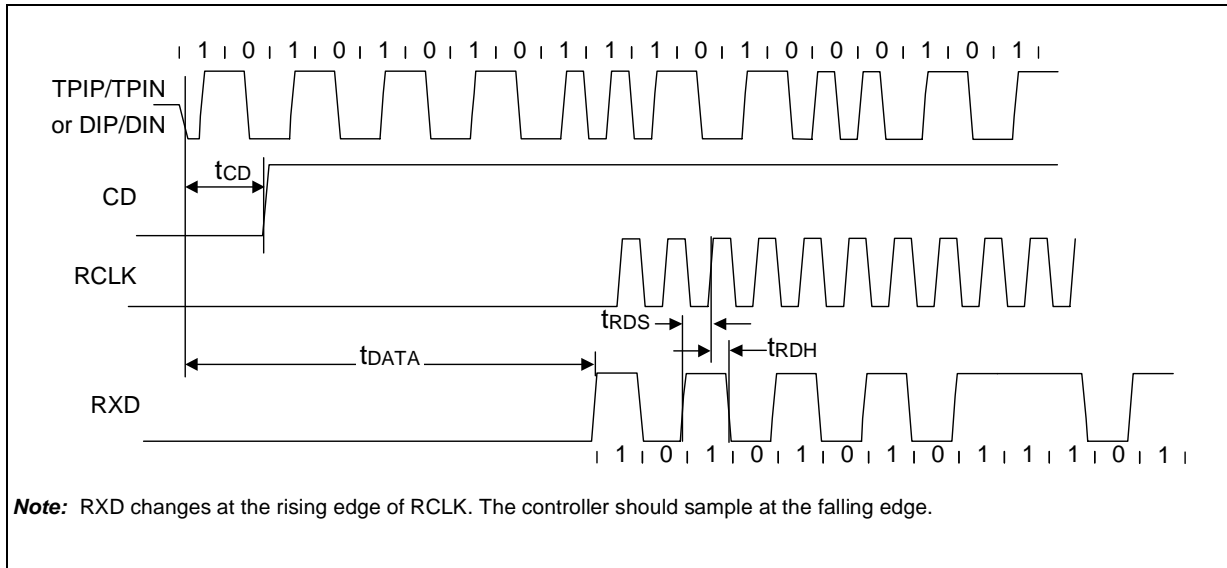

Figure 35. Mode 4 RCLK/End-of-Frame Timing

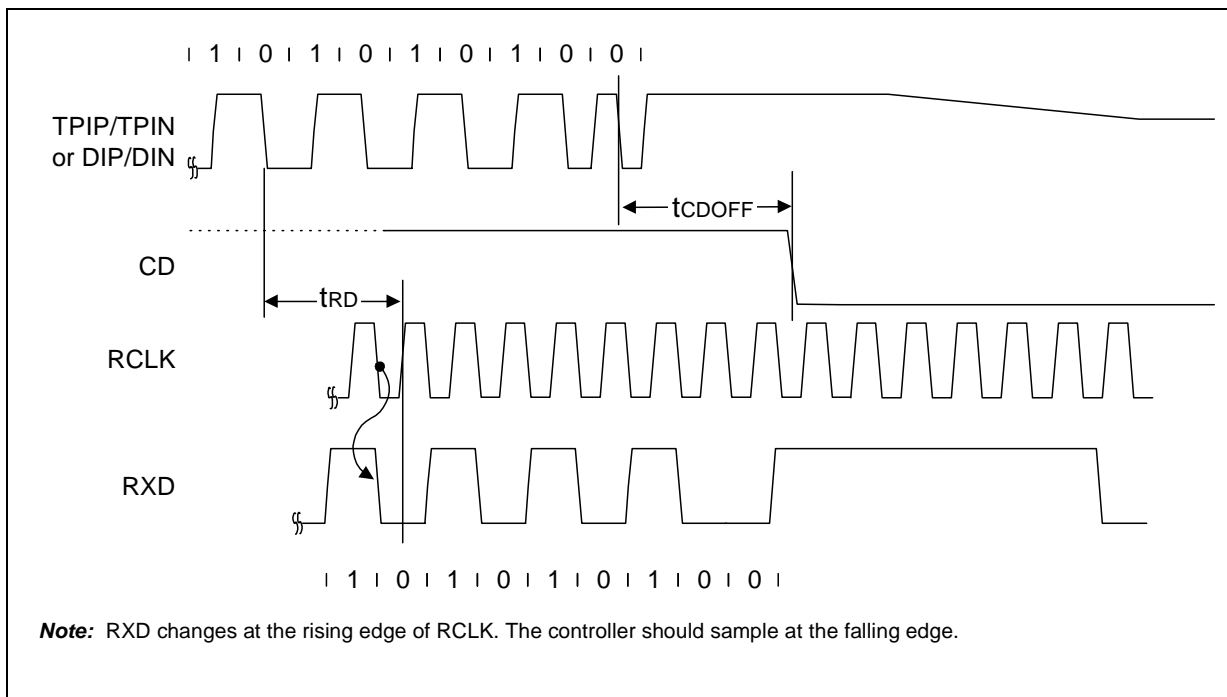

Figure 36. Mode 4 Transmit Timing

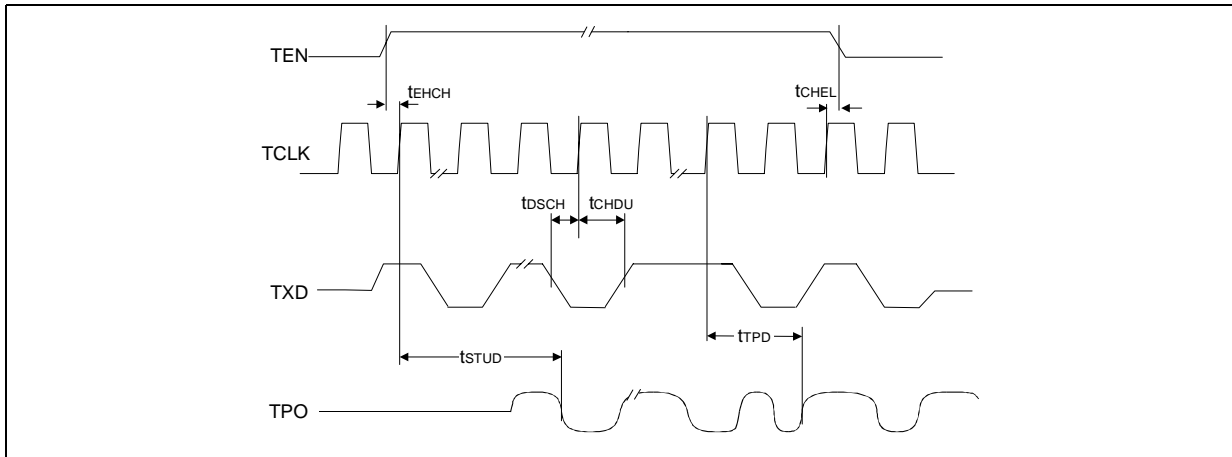

Figure 37. Mode 4 Collision Detect Timing

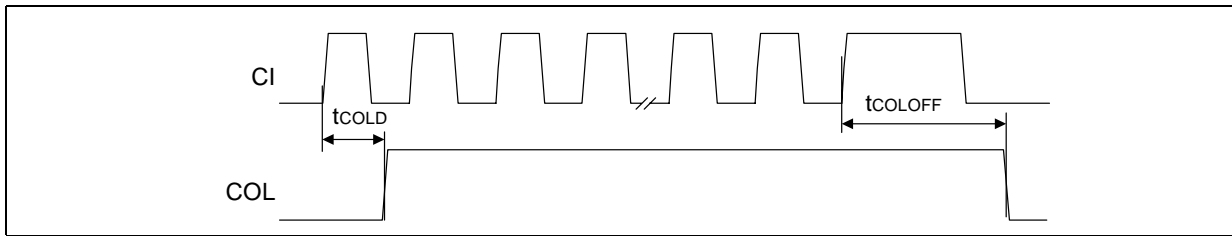

Figure 38. Mode 4 COL/SQE Output Timing

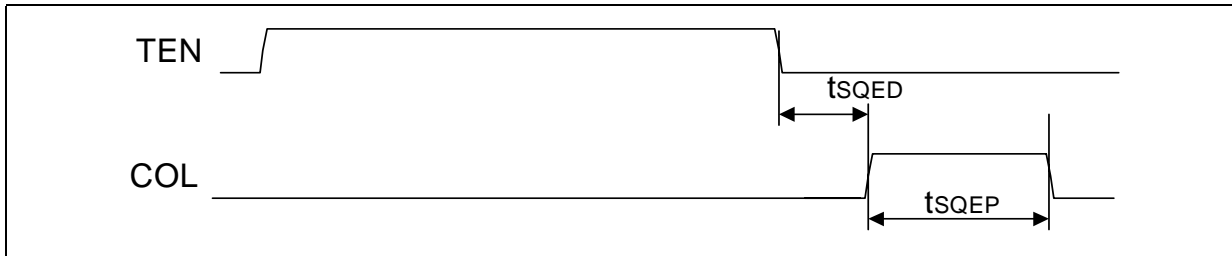
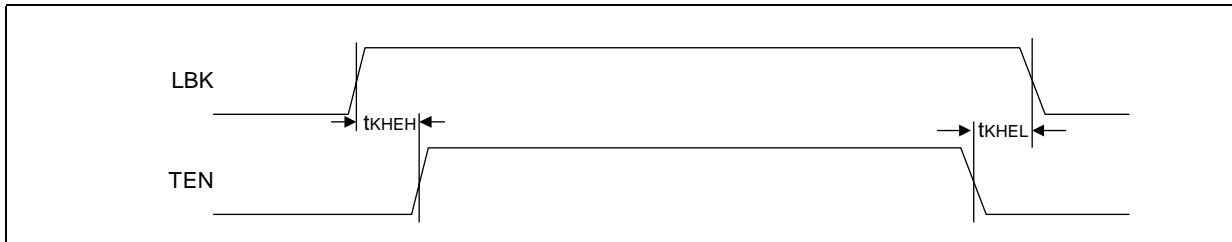

Figure 39. Mode 4 Loopback Timing



4.5 Timing Diagrams for Mode 5 (MD2, 1, 0 = High, High, Low) Figures 40 - 45

Figure 40. Mode 5 RCLK/Start-of-Frame Timing

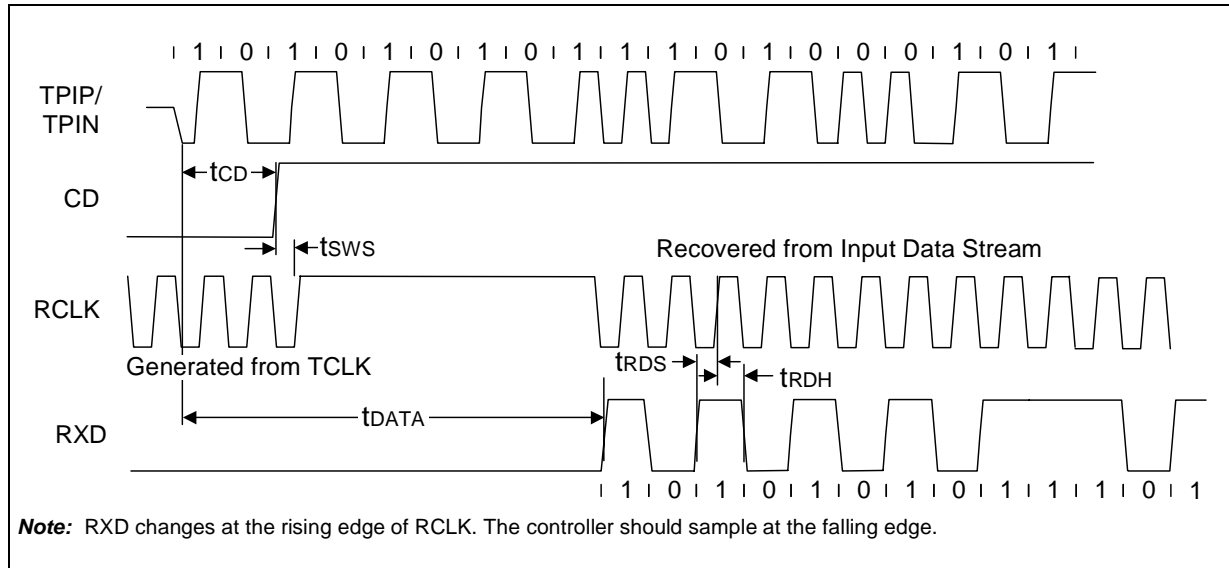

Figure 41. Mode 5 RCLK/End-of-Frame Timing

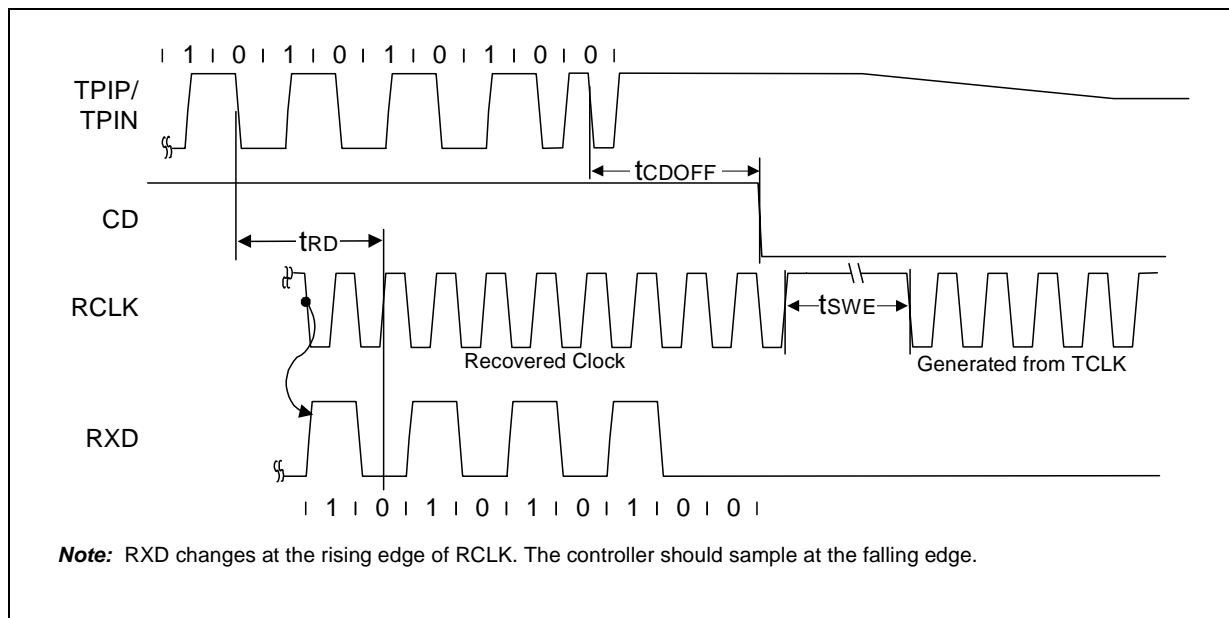

Figure 42. Mode 5 Transmit Timing

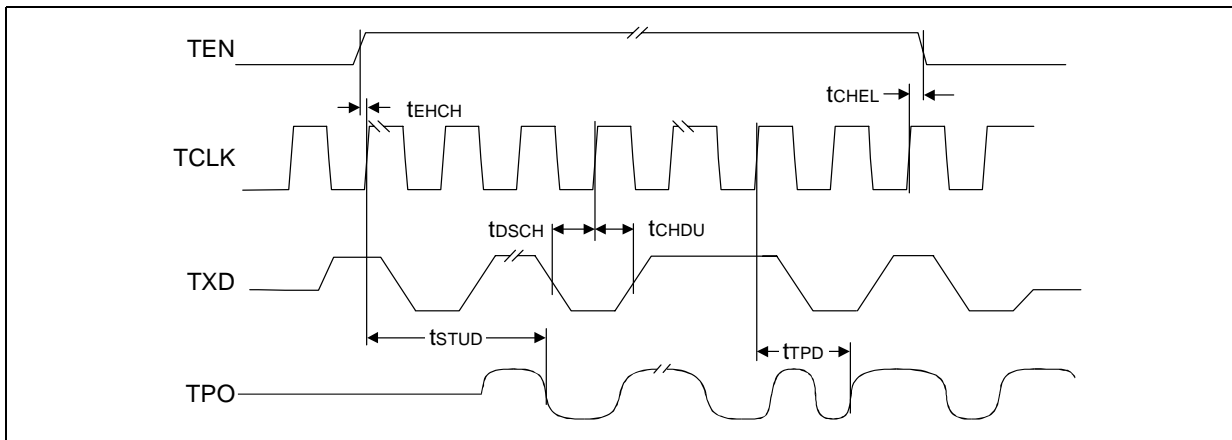

Figure 43. Mode 5 Collision Detect Timing

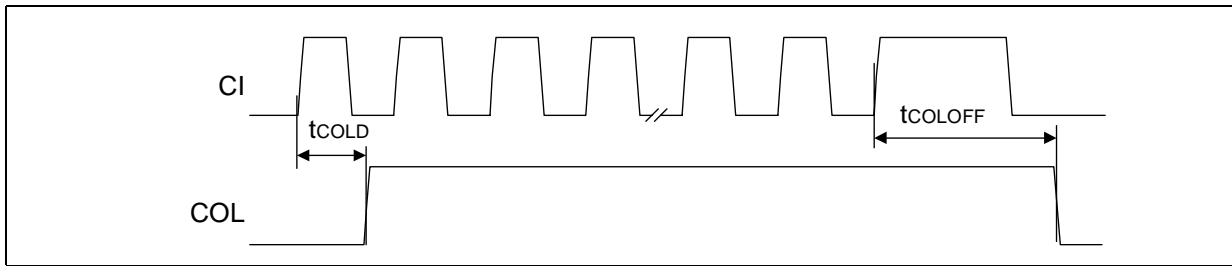

Figure 44. Mode 5 COL/SQE Output Timing

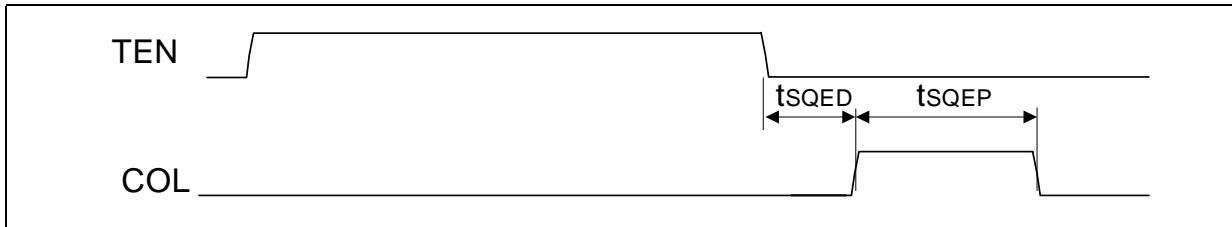
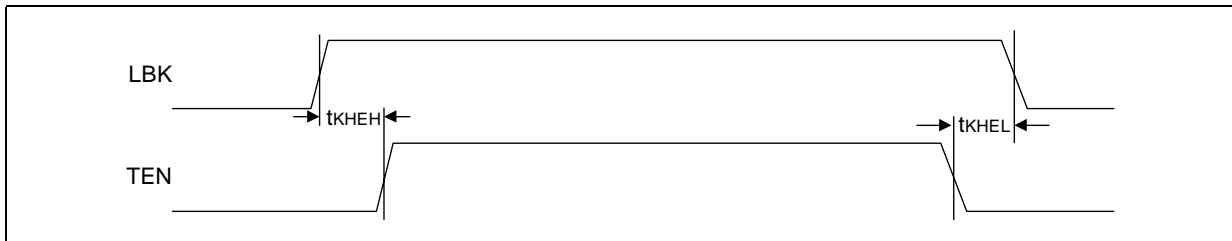

Figure 45. Mode 5 Loopback Timing



5.0 Mechanical Specifications

Figure 46. 44-Pin PLCC Package Specifications

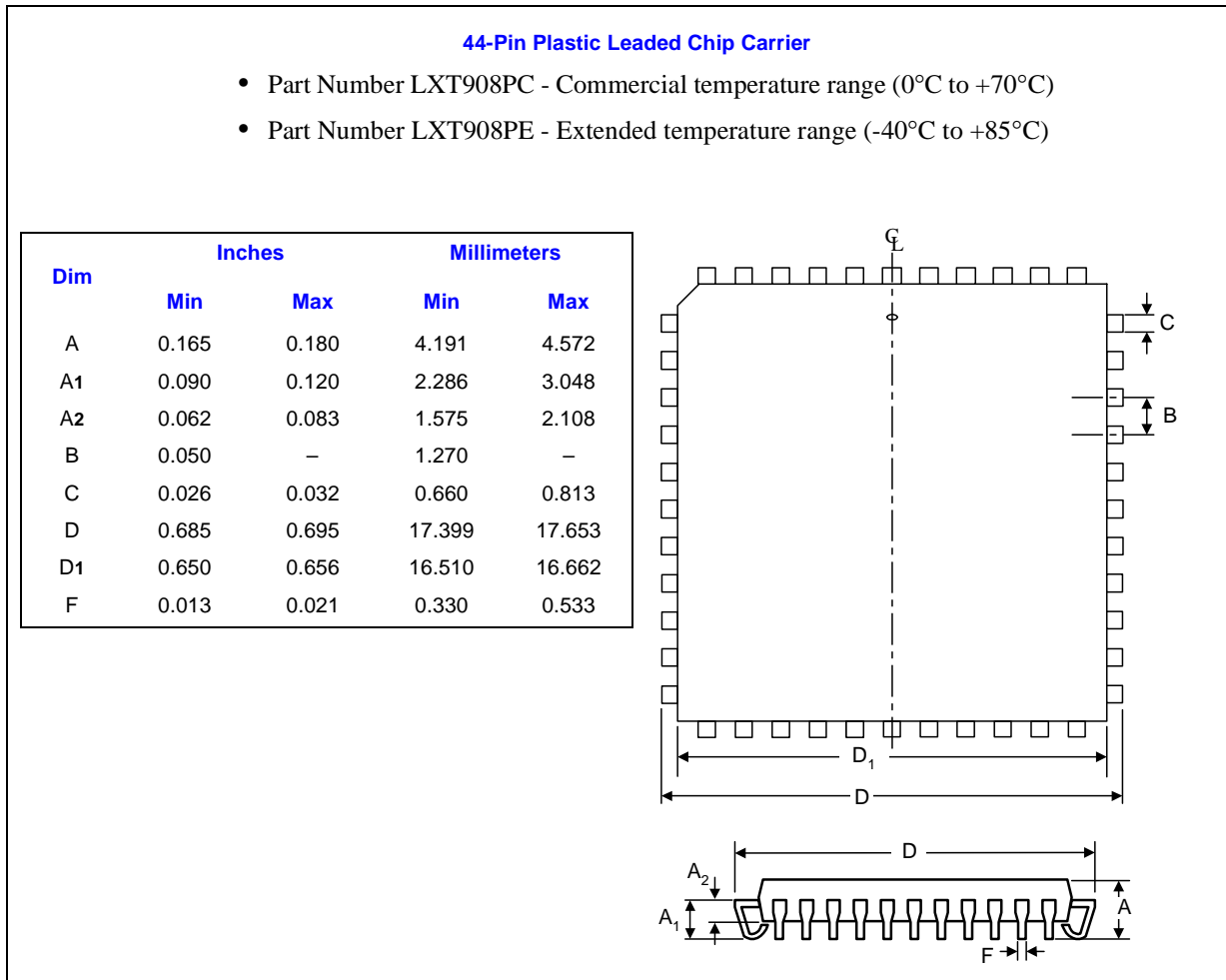
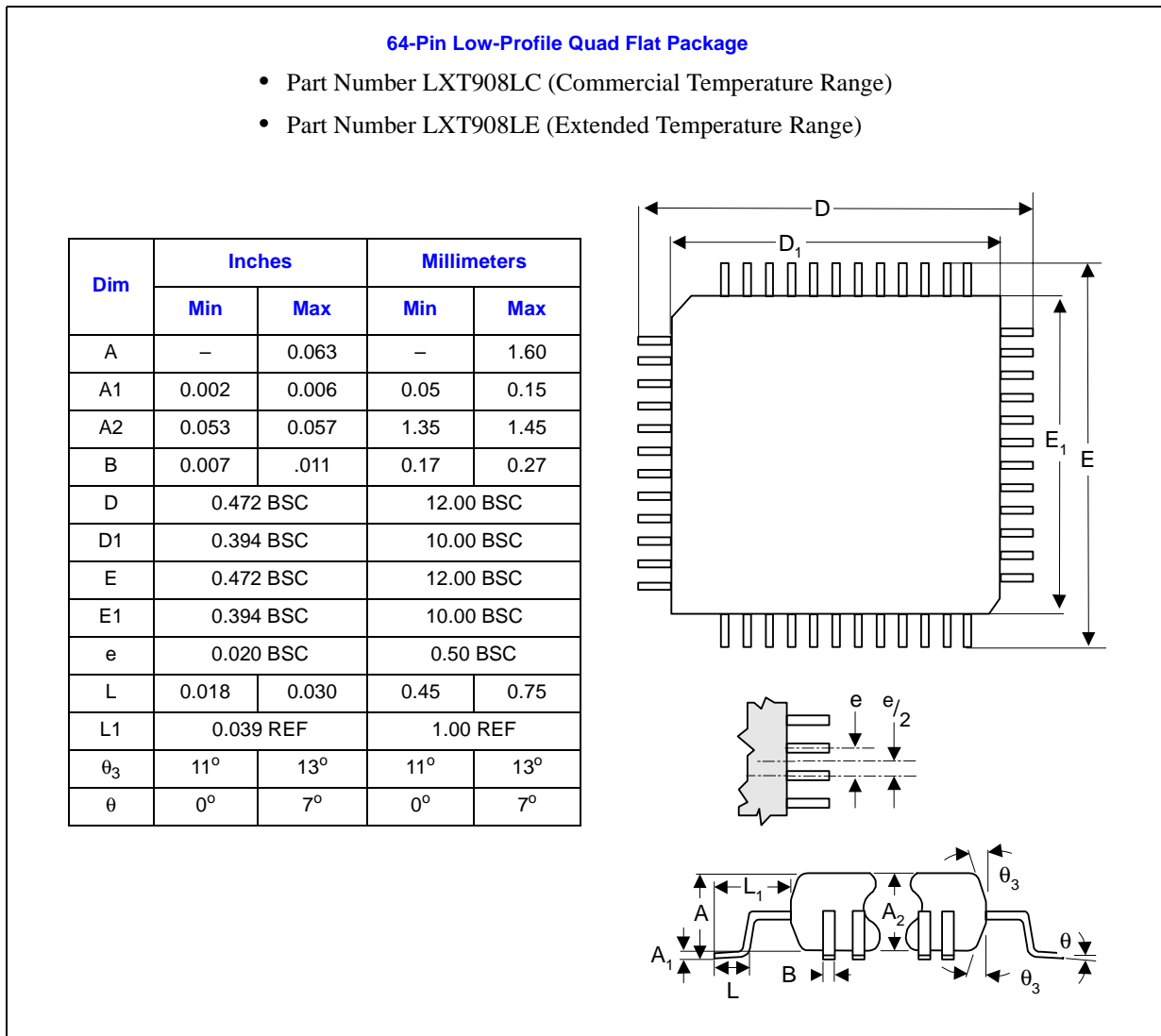

Figure 47. 64-Pin LQFP Package Specifications

Appendix A Ordering Information

Table 14. Product Information

Number	Revision	Qualification	Tray MM	Tape & Reel MM
DJLXT908LC.A4	A4	S	831651	831809
DJLXT908LE.A4	A4	S	831652	831810
NLXT908PC.A4	A4	S	831668	831824
NLXT908PE.A4	A4	S	831669	831825

Figure 48. Ordering Information - Sample

