

1.0 AMP SURFACE MOUNT FAST RECOVERY RECTIFIERS



VOLTAGE RANGE
50 to 600 Volts
CURRENT
1.0 Ampere

FEATURES

- * Low forward voltage drop
- * Low leakage current
- * High reliability

MECHANICAL DATA

- * Case: Molded plastic
- * Epoxy: UL 94V-0 rate flame retardant
- * Metallurgically bonded construction
- * Polarity: Color band denotes cathode end
- * Mounting position: Any
- * Weight: 0.015 grams

MELF/LL-41

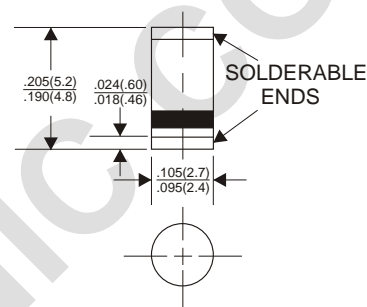

Dimensions in inches and (millimeters)

MAXIMUM RATINGS AND ELECTRICAL CHARACTERISTICS

Rating 25°C ambient temperature unless otherwise specified.
Single phase half wave, 60Hz, resistive or inductive load.
For capacitive load, derate current by 20%.

TYPE NUMBER	DL4933	DL4934	DL4935	DL4936	DL4937	UNITS	
Maximum Recurrent Peak Reverse Voltage	50	100	200	400	600	V	
Maximum RMS Voltage	35	70	140	280	420	V	
Maximum DC Blocking Voltage	50	100	200	400	600	V	
Maximum Average Forward Rectified Current .375"(9.5mm) Lead Length at Ta=55°C						1.0	A
Peak Forward Surge Current, 8.3 ms single half sine-wave superimposed on rated load (JEDEC method)						30	A
Maximum Instantaneous Forward Voltage at 1.0A						1.3	V
Maximum DC Reverse Current Ta=25°C						5.0	mA
at Rated DC Blocking Voltage Ta=100°C						100	mA
Maximum Reverse Recovery Time (Note 1)						200	nS
Typical Junction Capacitance (Note 2)						15	pF
Operating and Storage Temperature Range Tj, Tstg						-65 — +175	°C

NOTES:

1. Reverse Recovery Time test condition: IF=1.0A, VR=30V.
2. Measured at 1MHz and applied reverse voltage of 4.0V D.C.

RATING AND CHARACTERISTIC CURVES (SM4933 THRU SM4937)

FIG.1-TYPICAL FORWARD CHARACTERISTICS

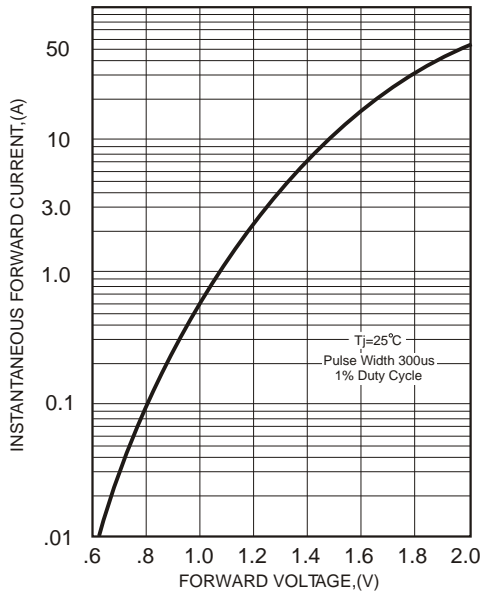

FIG.2-TYPICAL FORWARD CURRENT DERATING CURVE

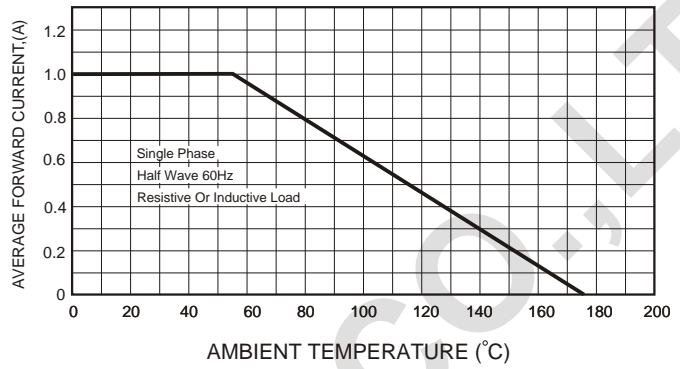
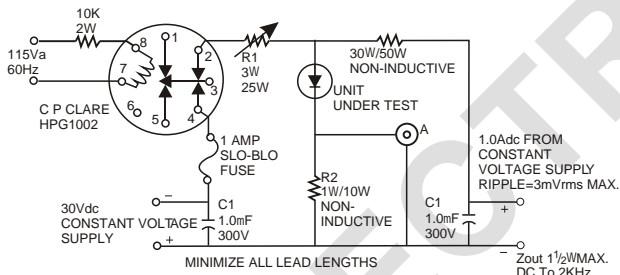

FIG.3- TEST CIRCUIT DIAGRAM AND REVERSE RECOVERY TIME CHARACTERISTICS



A-TEKTRONIX 545A, K PLUG IN
PRE AMP P6000 PROBE OR EQUIVALENT
R1- ADJUSTED FOR 14 BETWEEN
POINT 2 OF RELAY AND RECTIFIER
INDUCTIVE=3.8mH
R2- TEN 1W 10 W% CARBON CORE
IN PARALLEL
 $T_A = 25 \pm 10^\circ\text{C}$ FOR RECTIFIER

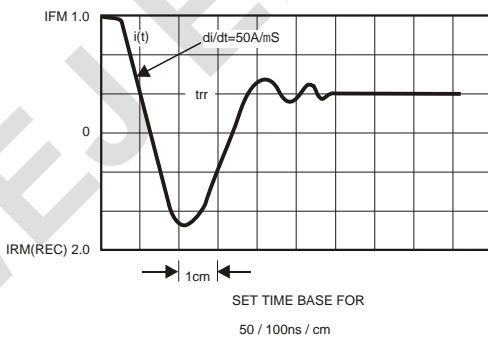

FIG.4-MAXIMUM NON-REPETITIVE FORWARD SURGE CURRENT

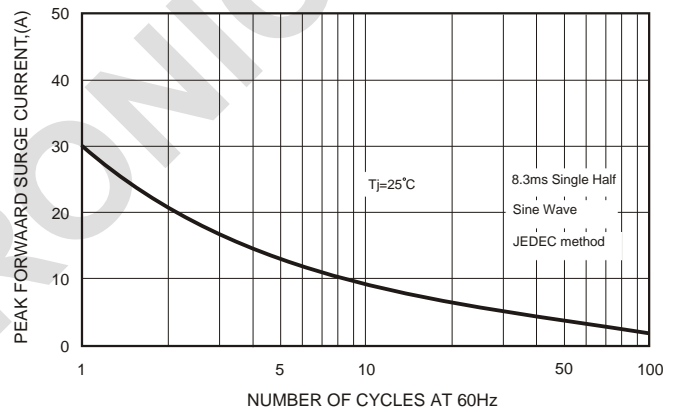

FIG.5-TYPICAL JUNCTION CAPACITANCE

