

DM7446A, DM7447A BCD to 7-Segment Decoders/Drivers

General Description

The DM7446A and DM7447A feature active-LOW outputs designed for driving common-anode LEDs or incandescent indicators directly. All of the circuits have full ripple-blanking input/output controls and a lamp test input. Segment identification and resultant displays are shown on a following page. Display patterns for BCD input counts above nine are unique symbols to authenticate input conditions.

All of the circuits incorporate automatic leading and/or trailing-edge, zero-blanking control (RBI and RBO). Lamp test (LT) of these devices may be performed at any time when the BI/RBO node is at a HIGH logic level. All types contain an overriding blanking input (BI) which can be used to control the lamp intensity (by pulsing) or to inhibit the outputs.

Features

- All circuit types feature lamp intensity modulation capability
- Open-collector outputs drive indicators directly
- Lamp-test provision
- Leading/trailing zero suppression

Ordering Code:

Order Number	Package Number	Package Description
DM7446AN	N16E	16-Lead Plastic Dual-In-Line Package (PDIP), JEDEC MS-001, 0.300" Wide
DM7447AN	N16E	16-Lead Plastic Dual-In-Line Package (PDIP), JEDEC MS-001, 0.300" Wide

Connection Diagram

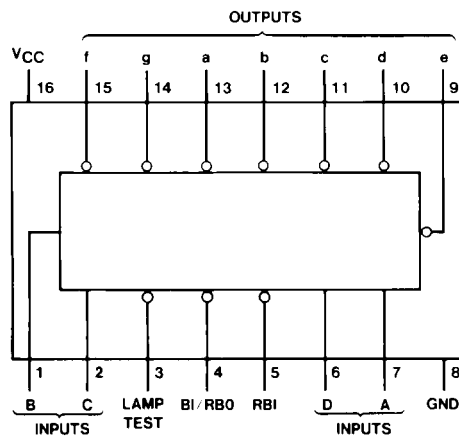

Function Table

Decimal or Function	Inputs						BI/RBO (Note 1)	Outputs							Note
	LT	RBI	D	C	B	A		a	b	c	d	e	f	g	
0	H	H	L	L	L	L	H	L	L	L	L	L	L	H	(Note 2)
1	H	X	L	L	L	H	H	H	L	L	H	H	H	H	
2	H	X	L	L	H	L	H	L	L	H	L	L	H	L	
3	H	X	L	L	H	H	H	L	L	L	L	H	H	L	
4	H	X	L	H	L	L	H	H	L	L	H	H	L	L	
5	H	X	L	H	L	H	H	L	H	L	L	H	L	L	
6	H	X	L	H	H	L	H	H	H	L	L	L	L	L	
7	H	X	L	H	H	H	H	L	L	L	H	H	H	H	
8	H	X	H	L	L	L	H	L	L	L	L	L	L	L	
9	H	X	H	L	L	H	H	L	L	L	H	H	L	L	
10	H	X	H	L	H	L	H	H	H	H	L	L	H	L	
11	H	X	H	L	H	H	H	H	H	L	L	H	H	L	
12	H	X	H	H	L	L	H	H	L	H	H	H	L	L	
13	H	X	H	H	L	H	H	L	H	H	L	H	L	L	
14	H	X	H	H	H	L	H	H	H	H	L	L	L	L	
15	H	X	H	H	H	H	H	H	H	H	H	H	H	H	
BI	X	X	X	X	X	X	L	H	H	H	H	H	H	H	(Note 3)
RBI	H	L	L	L	L	L	L	H	H	H	H	H	H	H	(Note 4)
LT	L	X	X	X	X	X	H	L	L	L	L	L	L	L	(Note 5)

H = HIGH level, L = LOW level, X = Don't Care

Note 1: BI/RBO is a wire-AND logic serving as blanking input (BI) and/or ripple-blanking output (RBO).

Note 2: The blanking input (BI) must be OPEN or held at a HIGH logic level when output functions 0 through 15 are desired. The ripple-blanking input (RBI) must be OPEN or HIGH if blanking of a decimal zero is not desired.

Note 3: When a LOW logic level is applied directly to the blanking input (BI), all segment outputs are HIGH regardless of the level of any other input.

Note 4: When ripple-blanking input (RBI) and inputs A, B, C, and D are at a LOW level with the lamp test input HIGH, all segment outputs go H and the ripple-blanking output (RBO) goes to a LOW level (response condition).

Note 5: When the blanking input/ripple-blanking output (BI/RBO) is OPEN or held HIGH and a LOW is applied to the lamp-test input, all segment outputs are L.

Logic Diagram

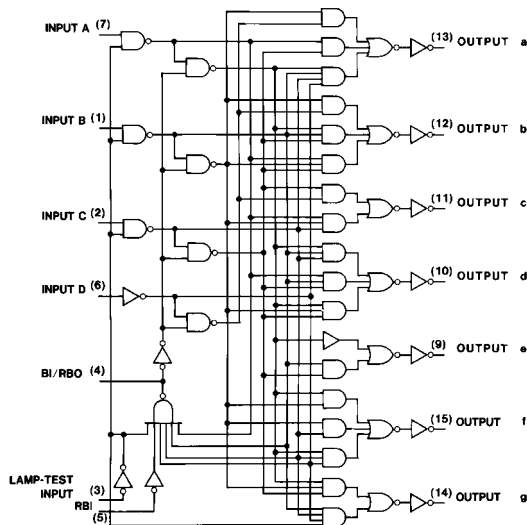

Absolute Maximum Ratings(Note 6)

Supply Voltage	7V
Input Voltage	5.5V
Operating Free Air Temperature Range	0°C to +70°C
Storage Temperature Range	-65°C to +150°C

Note 6: The "Absolute Maximum Ratings" are those values beyond which the safety of the device cannot be guaranteed. The device should not be operated at these limits. The parametric values defined in the Electrical Characteristics tables are not guaranteed at the absolute maximum ratings. The "Recommended Operating Conditions" table will define the conditions for actual device operation.

Recommended Operating Conditions

Symbol	Parameter	Min	Nom	Max	Units
DM7446A					
V _{CC}	Supply Voltage	4.75	5	5.25	V
V _{IH}	HIGH Level Input Voltage	2			V
V _{IL}	LOW Level Input Voltage			0.8	V
V _{OH}	HIGH Level Output Voltage (a thru g)			30	V
I _{OH}	HIGH Level Output Current (BI/RBO)			-0.2	μA
I _{OL}	LOW Level Output Current (a thru g)			40	mA
I _{OL}	LOW Level Output Current (BI/RBO)			8	mA
T _A	Free Air Operating Temperature	0		70	°C
DM7447A					
V _{CC}	Supply Voltage	4.75	5	5.25	V
V _{IH}	HIGH Level Input Voltage	2			V
V _{IL}	LOW Level Input Voltage			0.8	V
V _{OH}	HIGH Level Output Voltage (a thru g)			15	V
I _{OH}	HIGH Level Output Current (BI/RBO)			-0.2	μA
I _{OL}	LOW Level Output Current (a thru g)			40	mA
I _{OL}	LOW Level Output Current (BI/RBO)			8	mA
T _A	Free Air Operating Temperature	0		70	°C

DM7446A Electrical Characteristics

over recommended operating free air temperature range (unless otherwise noted)

Symbol	Parameter	Conditions	Min	Typ (Note 7)	Max	Units
V_I	Input Clamp Voltage	$V_{CC} = \text{Min}$, $I_I = -12 \text{ mA}$			-1.5	V
V_{OH}	HIGH Level Output Voltage (BI/RBO)	$V_{CC} = \text{Min}$ $I_{OH} = \text{Max}$	2.4	3.7		V
I_{CEX}	HIGH Level Output Current (a thru g)	$V_{CC} = \text{Max}$, $V_O = 30\text{V}$ $V_{IL} = \text{Max}$, $V_{IH} = \text{Min}$			250	μA
V_{OL}	LOW Level Output Voltage	$V_{CC} = \text{Min}$, $I_{OL} = \text{Max}$ $V_{IH} = \text{Min}$, $V_{IL} = \text{Max}$		0.3	0.4	V
I_I	Input Current @ Max Input Voltage	$V_{CC} = \text{Max}$, $V_I = 5.5\text{V}$ (Except BI/RBO)			1	mA
I_{IH}	HIGH Level Input Current	$V_{CC} = \text{Max}$, $V_I = 2.4\text{V}$ (Except BI/RBO)			40	μA
I_{IL}	LOW Level Input Current	$V_{CC} = \text{Max}$			-4	mA
		$V_I = 0.4\text{V}$	BI/RBO		-1.6	
I_{OS}	Short Circuit Output Current	$V_{CC} = \text{Max}$ (BI/RBO)			-4	mA
I_{CC}	Supply Current	$V_{CC} = \text{Max}$ (Note 8)		60	103	mA

Note 7: All typicals are at $V_{CC} = 5\text{V}$, $T_A = 25^\circ\text{C}$.

Note 8: I_{CC} is measured with all outputs OPEN and all inputs at 4.5V.

DM7446A Switching Characteristics

at $V_{CC} = 5\text{V}$ and $T_A = 25^\circ\text{C}$

Symbol	Parameter	Conditions	Min	Max	Units
t_{PLH}	Propagation Delay Time	$C_L = 15 \text{ pF}$ $R_L = 120\Omega$		100	ns
	LOW-to-HIGH Level Output				
t_{PHL}	Propagation Delay Time			100	ns
	HIGH-to-LOW Level Output				

DM7447A Electrical Characteristics

over recommended operating free air temperature range (unless otherwise noted)

Symbol	Parameter	Conditions	Min	Typ (Note 9)	Max	Units
V_I	Input Clamp Voltage	$V_{CC} = \text{Min}$, $I_I = -12 \text{ mA}$			-1.5	V
V_{OH}	HIGH Level Output Voltage (BI/RBO)	$V_{CC} = \text{Min}$ $I_{OH} = \text{Max}$	2.4	3.7		V
I_{CEX}	HIGH Level Output Current (a thru g)	$V_{CC} = \text{Max}$, $V_O = 15\text{V}$ $V_{IL} = \text{Max}$, $V_{IH} = \text{Min}$			250	μA
V_{OL}	LOW Level Output Voltage	$V_{CC} = \text{Min}$, $I_{OL} = \text{Max}$ $V_{IH} = \text{Min}$, $V_{IL} = \text{Max}$		0.3	0.4	V
I_I	Input Current @ Max Input Voltage	$V_{CC} = \text{Max}$, $V_I = 5.5\text{V}$			1	mA
I_{IH}	HIGH Level Input Current	$V_{CC} = \text{Max}$, $V_I = 2.4\text{V}$			40	μA
I_{IL}	LOW Level Input Current	$V_{CC} = \text{Max}$ $V_I = 0.4\text{V}$			-4	mA
		BI/RBO Others			-1.6	
I_{OS}	Short Circuit Output Current	$V_{CC} = \text{Max}$ (BI/RBO)			-4	mA
I_{CC}	Supply Current	$V_{CC} = \text{Max}$ (Note 10)		60	103	mA

Note 9: All typicals are at $V_{CC} = 5\text{V}$, $T_A = 25^\circ\text{C}$.**Note 10:** I_{CC} is measured with all outputs OPEN and all inputs at 4.5V.**DM7447A Switching Characteristics**at $V_{CC} = 5\text{V}$ and $T_A = 25^\circ\text{C}$

Symbol	Parameter	Conditions	Min	Max	Units
t_{PLH}	Propagation Delay Time LOW-to-HIGH Level Output	$C_L = 15 \text{ pF}$ $R_L = 120\Omega$		100	ns
t_{PHL}	Propagation Delay Time HIGH-to-LOW Level Output			100	ns

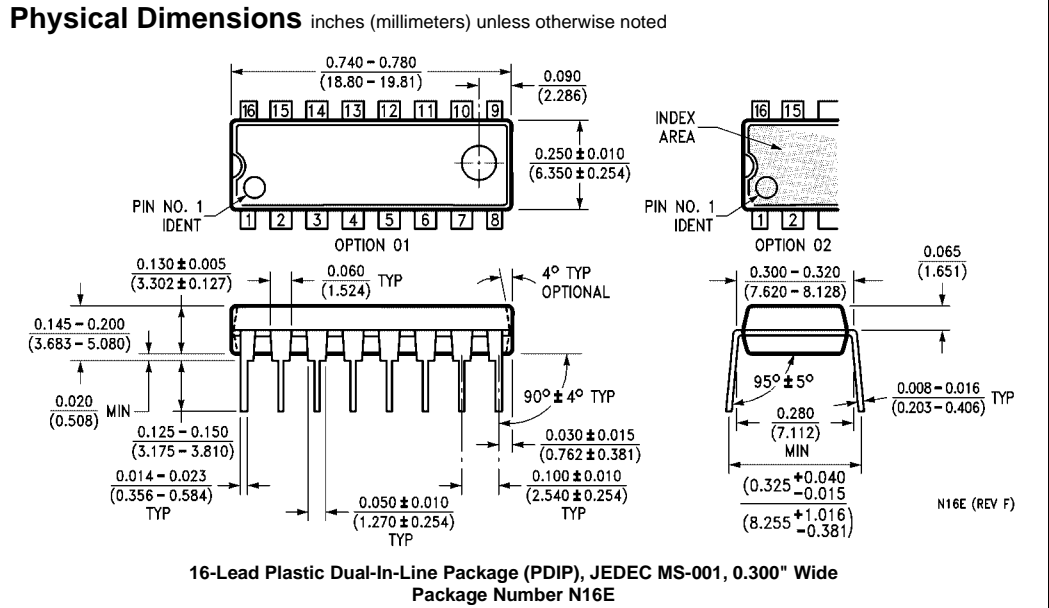

Fairchild does not assume any responsibility for use of any circuitry described, no circuit patent licenses are implied and Fairchild reserves the right at any time without notice to change said circuitry and specifications.

LIFE SUPPORT POLICY

FAIRCHILD'S PRODUCTS ARE NOT AUTHORIZED FOR USE AS CRITICAL COMPONENTS IN LIFE SUPPORT DEVICES OR SYSTEMS WITHOUT THE EXPRESS WRITTEN APPROVAL OF THE PRESIDENT OF FAIRCHILD SEMICONDUCTOR CORPORATION. As used herein:

1. Life support devices or systems are devices or systems which, (a) are intended for surgical implant into the body, or (b) support or sustain life, and (c) whose failure to perform when properly used in accordance with instructions for use provided in the labeling, can be reasonably expected to result in a significant injury to the user.
2. A critical component in any component of a life support device or system whose failure to perform can be reasonably expected to cause the failure of the life support device or system, or to affect its safety or effectiveness.

www.fairchildsemi.com