

## DM74S140 Dual 4-Input NAND 50Ω Line Driver

### General Description

This device contains two independent line driver gates each of which performs the logic NAND function.

### Connection Diagram

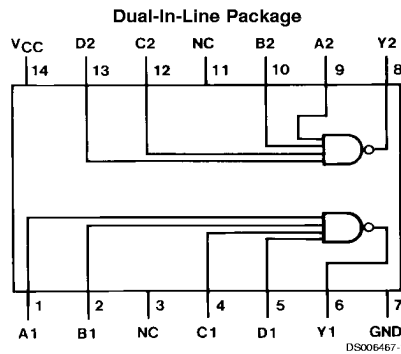

### Function Table

$$Y = \overline{ABCD}$$

Inputs				Output
A	B	C	D	Y
X	X	X	L	H
X	X	L	X	H
X	L	X	X	H
L	X	X	X	H
H	H	H	H	L

H = High Logic Level  
L = Low Logic Level  
X = Either Low or High Logic Level

## Absolute Maximum Ratings (Note 1)

Supply Voltage	7V	DM54S	-55°C to +125°C
Input Voltage	5.5V	DM74S	0°C to +70°C
Operating Free Air Temperature Range		Storage Temperature Range	-65°C to +150°C

## Recommended Operating Conditions

Symbol	Parameter	DM54S140			DM74S140			Units
		Min	Nom	Max	Min	Nom	Max	
V <sub>CC</sub>	Supply Voltage	4.5	5	5.5	4.75	5	5.25	V
V <sub>IH</sub>	High Level Input Voltage	2			2			V
V <sub>IL</sub>	Low Level Input Voltage			0.8			0.8	V
I <sub>OH</sub>	High Level Output Current			-3			-3	mA
I <sub>OL</sub>	Low Level Output Current			60			60	mA
T <sub>A</sub>	Free Air Operating Temperature	-55		125	0		70	°C

**Note 1:** The "Absolute Maximum Ratings" are those values beyond which the safety of the device cannot be guaranteed. The device should not be operated at these limits. The parametric values defined in the "Electrical Characteristics" table are not guaranteed at the absolute maximum ratings. The "Recommended Operating Conditions" table will define the conditions for actual device operation.

## Electrical Characteristics

over recommended operating free air temperature (unless otherwise noted)

Symbol	Parameter	Conditions	Min	Typ (Note 2)	Max	Units
V <sub>I</sub>	Input Clamp Voltage	V <sub>CC</sub> = Min, I <sub>I</sub> = -18 mA			-1.2	V
V <sub>OH</sub>	High Level Output Voltage	V <sub>CC</sub> = Min, V <sub>IL</sub> = Max	DM54	2.5	3.4	V
		I <sub>OH</sub> = Max	DM74	2.7	3.4	
		V <sub>IL</sub> = 0.5V, R <sub>O</sub> = 50Ω to GND		2.0		
V <sub>OL</sub>	Low Level Output Voltage	V <sub>CC</sub> = Min, I <sub>OL</sub> = Max V <sub>IH</sub> = Min			0.5	V
I <sub>I</sub>	Input Current @ Max Input Voltage	V <sub>CC</sub> = Max, V <sub>I</sub> = 5.5V			1	mA
I <sub>IH</sub>	High Level Input Current	V <sub>CC</sub> = Max, V <sub>I</sub> = 2.7V			100	μA
I <sub>IL</sub>	Low Level Input Current	V <sub>CC</sub> = Max, V <sub>I</sub> = 0.5V			-4	mA
I <sub>OS</sub>	Short Circuit Output Current	V <sub>CC</sub> = Max (Note 3)	DM54	-50	-225	mA
			DM74	-50	-225	
I <sub>CCH</sub>	Supply Current with Outputs High	V <sub>CC</sub> = Max		10	18	mA
I <sub>CCL</sub>	Supply Current with Outputs Low	V <sub>CC</sub> = Max		25	44	mA

## Switching Characteristics

at V<sub>CC</sub> = 5V and T<sub>A</sub> = 25°C

Symbol	Parameter	R <sub>L</sub> = 93Ω				Units
		C <sub>L</sub> = 50 pF		C <sub>L</sub> = 150 pF		
		Min	Max	Min	Max	
t <sub>PLH</sub>	Propagation Delay Time Low to High Level Output	2	6.5	3	9	ns
t <sub>PHL</sub>	Propagation Delay Time High to Low Level Output	2	6.5	3	9	ns

**Note 2:** All typicals are at V<sub>CC</sub> = 5V, T<sub>A</sub> = 25°C.

**Note 3:** Not more than one output should be shorted at a time, and the duration should not exceed one second.

**Physical Dimensions** inches (millimeters) unless otherwise noted

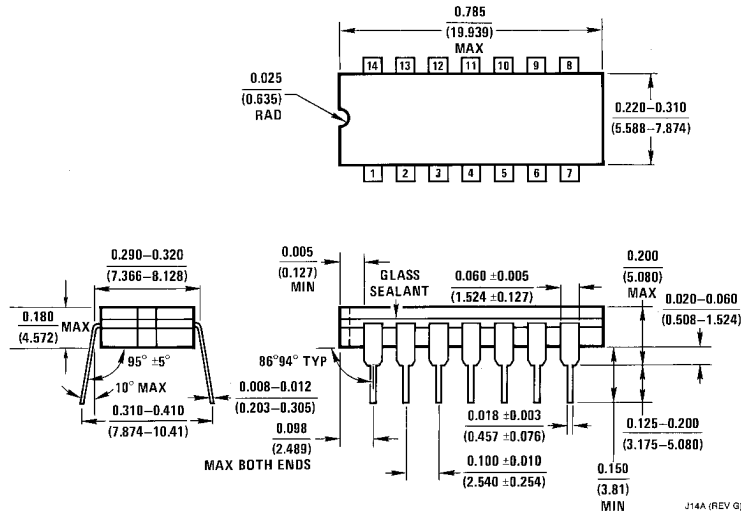

**14-Lead Ceramic Dual-In-Line Package (J)**  
Order Number DM54S140J  
Package Number J14A

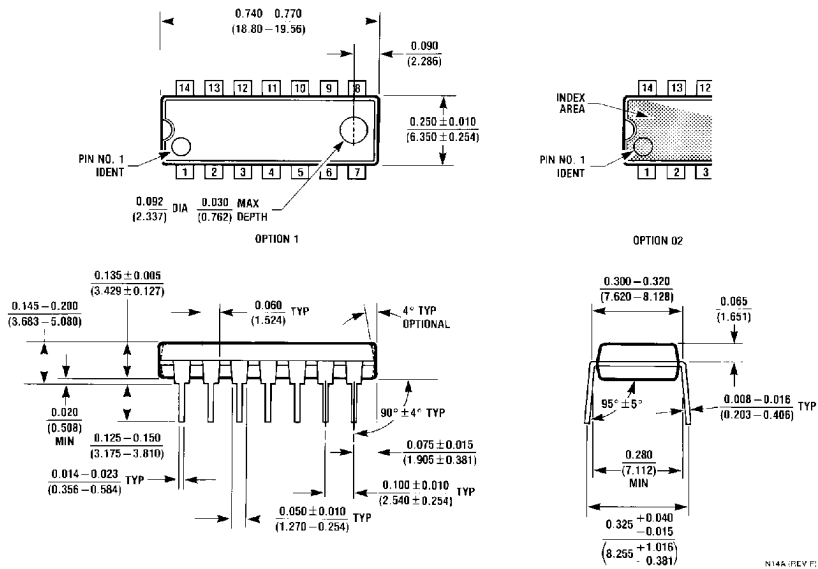

**14-Lead Molded Dual-In-Line Package (N)**  
Order Number DM74S140N  
Package Number N14A