



Micro Commercial Components

Micro Commercial Components
 20736 Marilla Street Chatsworth
 CA 91311
 Phone: (818) 701-4933
 Fax: (818) 701-4939

DTC114TCA

Features

- Built-in bias resistors enable the configuration of an inverter circuit without connecting external input resistors (see equivalent circuit)
- The bias resistors consist of thin-film resistors with complete isolation to allow negative biasing of the input. They also have the advantage of almost completely eliminating parasitic effects
- Only the on/off conditions need to be set for operation, making device design easy

Absolute Maximum Ratings

Parameter	Symbol	Value	Unit
Collector-Base Voltage	V_{CBO}	50	V
Collector-Emitter Voltage	V_{CEO}	50	V
Emitter-Base voltage	V_{EBO}	5	V
Collector Current-Continuous	I_C	100	mA
Collector Dissipation	P_C	200	mW
Junction Temperature	T_J	150	$^{\circ}C$
Storage Temperature Range	T_{STG}	-55~150	$^{\circ}C$

Electrical Characteristics

Sym	Parameter	Min	Typ	Max	Unit
$V_{(BR)CBO}$	Collector-Base Breakdown Voltage ($I_C=50\mu A, I_E=0$)	50	---	---	V
$V_{(BR)CEO}$	Collector-Emitter Breakdown Voltage ($I_C=1mA, I_B=0$)	50	---	---	V
$V_{(BR)EBO}$	Emitter-Base Breakdown Voltage ($I_E=50\mu A, I_C=0$)	5	---	---	V
I_{CBO}	Collector Cut-off Current ($V_{CB}=50V, I_E=0$)	---	---	0.5	μA
I_{EBO}	Emitter Cut-off Current ($V_{EB}=4V, I_C=0$)	---	---	0.5	μA
h_{FE}	DC Current Gain ($V_{CE}=5V, I_C=1mA$)	100	300	600	---
$V_{CE(sat)}$	Collector-Emitter Saturation Voltage ($I_C=10mA, I_B=1mA$)	---	---	0.3	V
R_1	Input Resistor	7	10	13	$K\Omega$
f_T	Transition Frequency ($V_{CE}=10V, I_C=-5mA, f=100MHz$)	---	250	---	MHz

NPN Digital Transistor

SOT-23

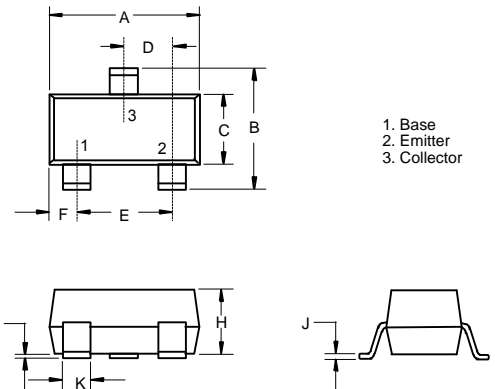

DIMENSIONS

DIM	INCHES		MM		NOTE
	MIN	MAX	MIN	MAX	
A	.110	.120	2.80	3.04	
B	.083	.098	2.10	2.64	
C	.047	.055	1.20	1.40	
D	.035	.041	.89	1.03	
E	.070	.081	1.78	2.05	
F	.018	.024	.45	.60	
G	.0005	.0039	.013	.100	
H	.035	.044	.89	1.12	
J	.003	.007	.085	.180	
K	.015	.020	.37	.51	

Suggested Solder Pad Layout

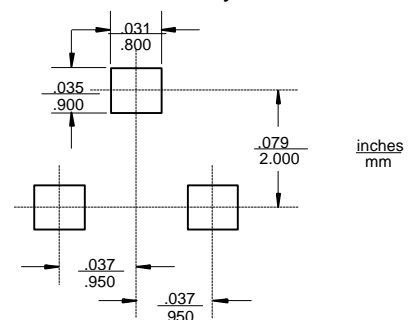

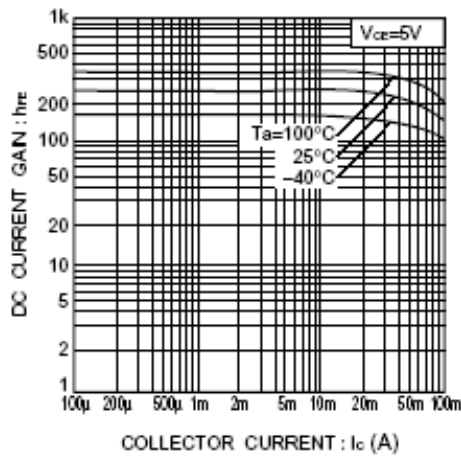

Fig.1 DC current gain vs. collector current

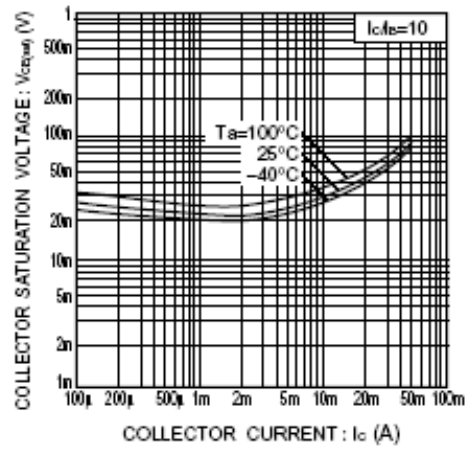

Fig.2 Collector-emitter saturation voltage vs. collector current

●Equivalent circuit

