



DV-704A Series

HIGH RELIABILITY HYBRID EMI FILTERS

DESCRIPTION

The DV-704A is a combined hybrid EMI filter and voltage spike protection module that is operable over the full military (-55 °C to +125 °C) temperature range with no power derating. The DV-704A EMI filter is designed to be used with VPT/Delta's DVSA, DVHF, DVTR, and DVFL series DC-DC converters to comply with the surge requirements of MIL-STD-704A, B, C, and D with 40 watts maximum output power. This device also reduces the reflected noise of the DC-DC converters to meet MIL-STD-461C CE03 and MIL-STD-461D CE102 limits. It also protects the DC-DC converters against the voltage spikes specified in MIL-STD-461C CS06 and conducted susceptibility in MIL-STD-461C CS01 and CS02.

These filters are designed and manufactured in a facility qualified to ISO9001 and certified to MIL-PRF-38534 and MIL-STD-883.

This product may incorporate one or more of the following U.S. patents:

5,784,266
5,790,389
5,963,438
5,999,433
6,005,780
6,084,792
6,118,673

FEATURES

- High Reliability
- Up to 2.0 Amps Maximum Current
- 45 dB Minimum Attenuation at 500 kHz
- Industry Standard Pinout
- Inrush Current Limit and Soft Start
- Under Voltage Lockout
- Clamps Output Voltage to 45 Volts Maximum
- Precision Seam Welded Hermetic Package
- Custom Versions Available
- Additional Environmental Screening Available
- Meets MIL-STD-704A, B, C, and D Surge Limits
- Compliant to MIL-STD-461C CE03 and MIL-STD-461D CE102 EMC Requirements
- Protects Against Conducted Susceptibility Specified in MIL-STD-461C, CS01 and CS02 and Against Voltage Spikes Specified in MIL-STD-461C CS06
- MIL-PRF-38534 Element Evaluated Components

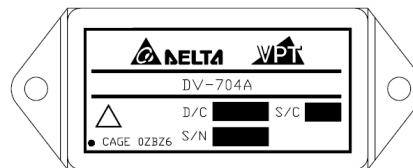

Figure 1 – DV-704A EMI Filter
(Exact marking may differ from that shown)

SPECIFICATIONS (T_{CASE} = -55°C to +125°C, V_{IN} = +28V ± 5%, Full Load, Unless Otherwise Specified)

ABSOLUTE MAXIMUM RATINGS

Input Voltage (Continuous)	40 V _{DC}	Power Dissipation (Continuous)	15 Watts
Input Voltage (Transient, up to 20μs)	600 Volts	Power Dissipation (Peak)	500 Watts
Output Current ³	2.0 Amps	Storage Temperature	-65°C to +150°C
Weight (Maximum)	50 grams	Lead Solder Temperature (10 seconds)	300°C
ESD Rating per MIL-PRF-38534	1B		

Parameter	Conditions	DV-704A			Units	
		Min	Typ	Max		
STATIC						
INPUT Voltage	Continuous	No Load	0	28	40	V
	Continuous	2.0 A Load	15	28	40	V
	Transient	100 ms, R _S = 0.0 Ω	-	-	80	V
	Transient ²	60 ms, R _S = 0.5 Ω	-	-	100	V
	Transient	20 μs, R _S = 50 Ω	-	-	600	V
Current ¹		No Load	-	-	10	mA
		Inhibited	-	-	2.0	mA
OUTPUT Voltage	Continuous	$V_{OUT} = V_{IN} - (I_{IN} \times R_{DC})$			V	
Current ^{3,4}	Continuous		0	-	2.0	A
INHIBIT PIN VOLTAGE ²		Open Circuit	-	14	16	V
		Inhibited	0	-	0.8	V
INHIBIT PIN CURRENT ²		Inhibit Pin Voltage = 0 to 0.8 V	-	-	-300	μA
UNDERVOLTAGE LOCKOUT			7.0	-	14	V
OUTPUT CLAMP VOLTAGE			43	-	47	V
INPUT SURGE LIMIT ²		2.0 A Load, 80 V	-	-	100	ms
		2.0 A Load, 100 V	-	-	80	ms
INPUT SPIKE LIMIT ²		2.0 A Load, 600 V, R _S = 50 Ω	-	-	20	μs
		2.0 A Load, 400 V, R _S = 0.5 Ω	-	-	20	μs
INPUT INRUSH CURRENT ²		V _{IN} = 0 – 28V, No Load C _L = 100μF	-	0.25	0.5	A _{PK}
DC RESISTANCE		Continuous, T _{case} = 25°C	-	-	450	mΩ
POWER DISSIPATION		Continuous	-	-	15	W
		Peak	-	-	500	W
NOISE REJECTION		f = 500 kHz	45	-	-	dB
CAPACITANCE ²		Pin to Case	-	20	-	nF
ISOLATION		Any Pin to Case, 500 V _{DC}	100	-	-	MΩ
MTBF (MIL-HDBK-217F)		AIF @ T _C = 55°C	-	0.627	-	MHrs

- Notes:
1. Derate linearly to 0 at 135°C.
 2. Verified by qualification testing.
 3. Maximum output power is linearly derated to 0 A from +125°C to +135°C.
 4. Rated current applies at any voltage.

BLOCK DIAGRAM

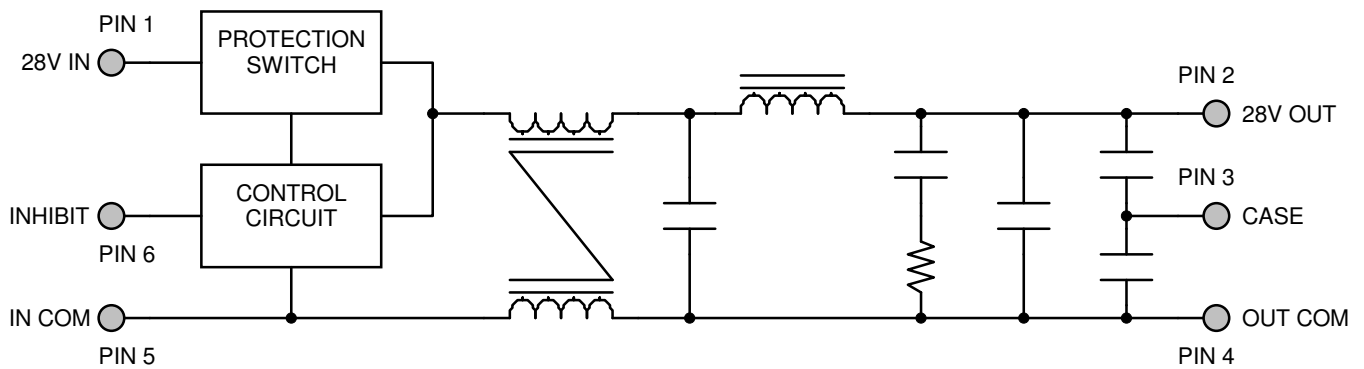

Figure 2

CONNECTION DIAGRAM

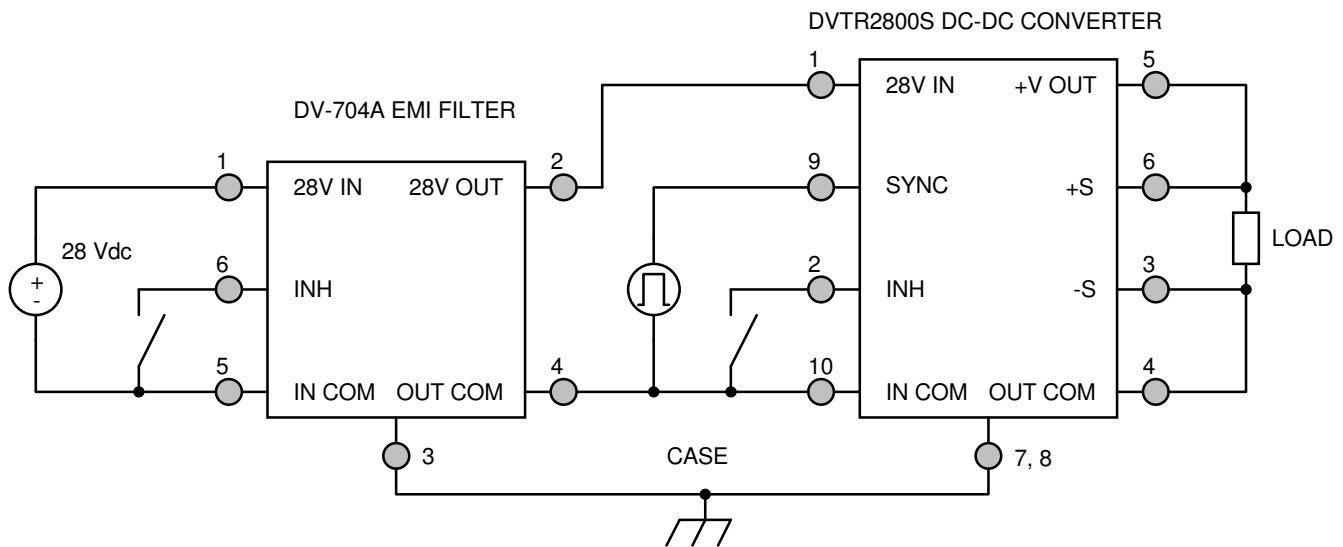

Figure 3 – DV-704A EMI Filter Hookup with Single Converter

INHIBIT DRIVE CONNECTION DIAGRAM

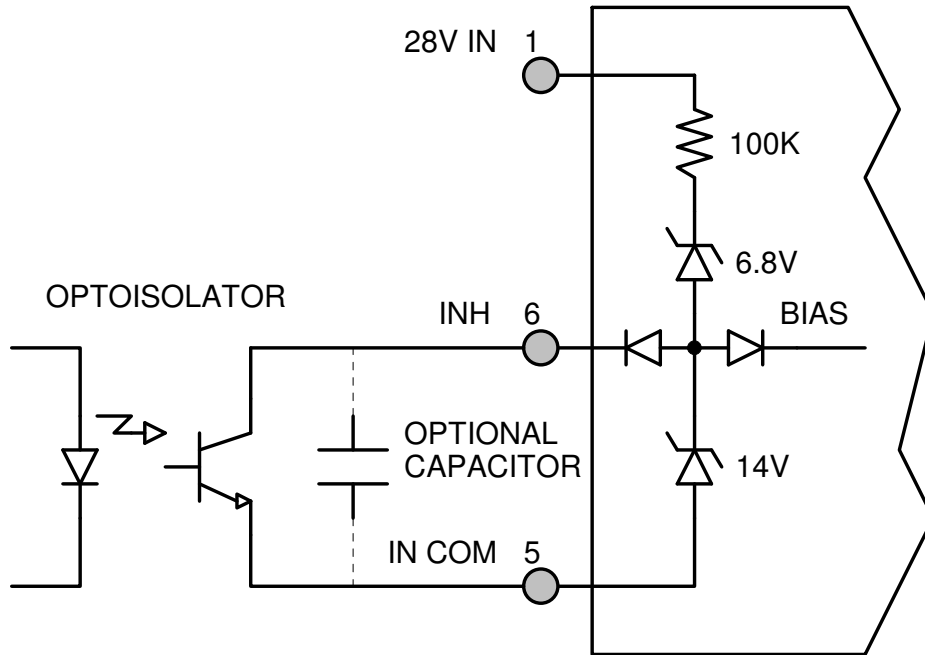

Figure 4 – Isolated Inhibit Drive
(Shown with optional capacitor for turn-on delay)

EMI MEASUREMENT METHODS CONNECTION DIAGRAMS

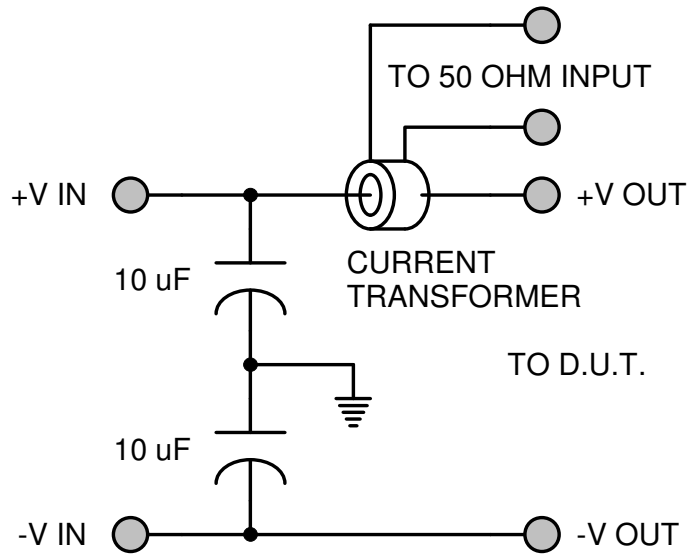

Figure 5 – MIL-STD-461C Measurement Method (Feedthrough Capacitor)

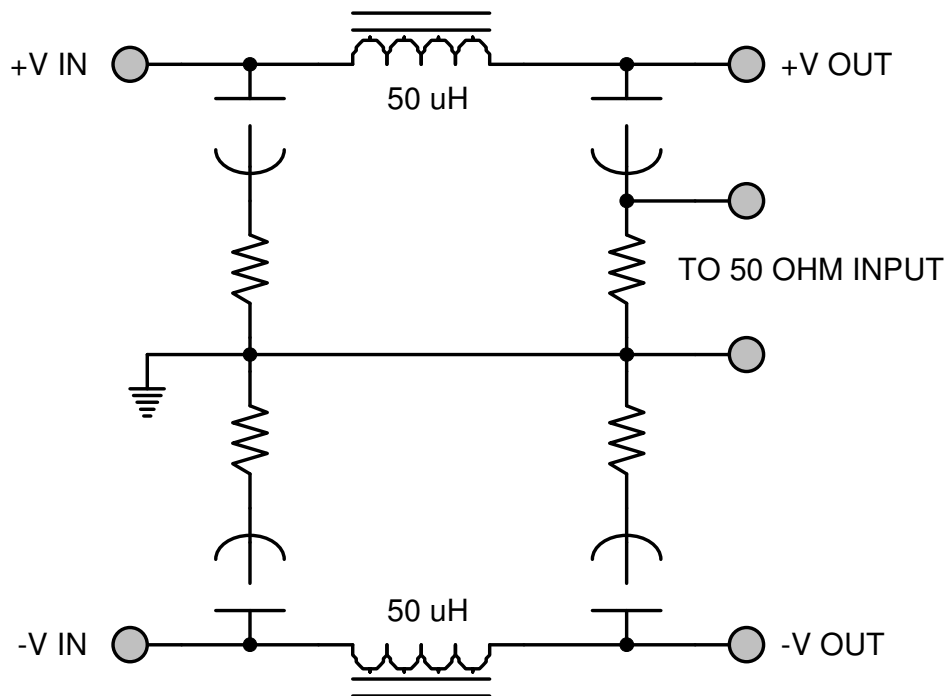

Figure 6 – MIL-STD-461D Measurement Method (LISN)

EMI PERFORMANCE CURVES

($T_{CASE} = 25^{\circ}C$, $V_{IN} = +28V \pm 5\%$, Full Load, Unless Otherwise Specified)

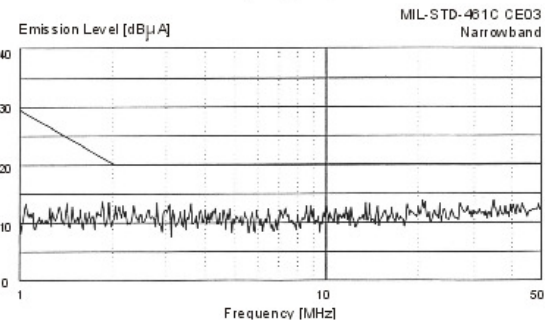
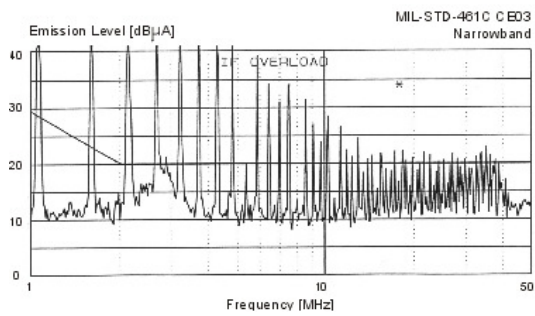
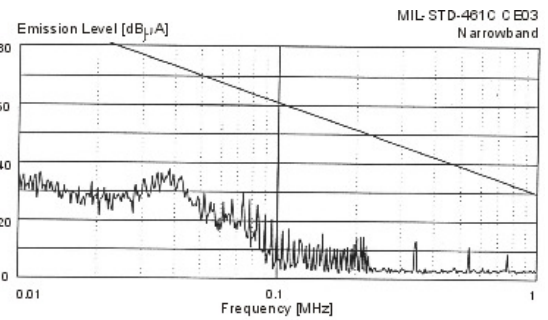
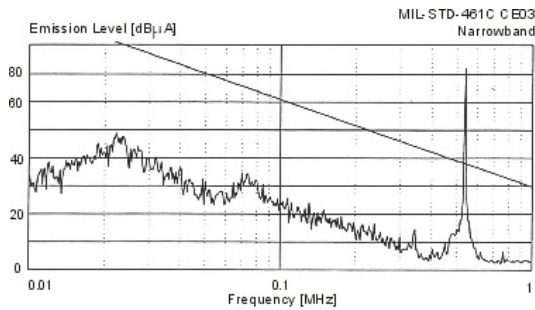

Figure 7 – MIL-STD-461C DVTR2800S Without EMI Filter

Figure 8 – MIL-STD-461C DVTR2800S With DV-704A EMI Filter

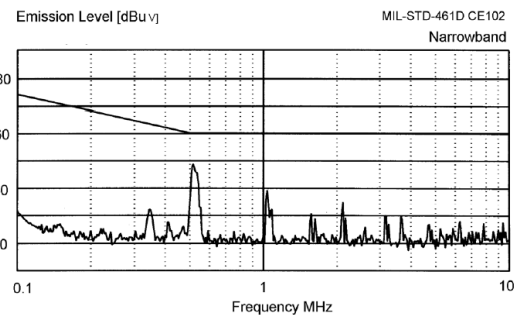
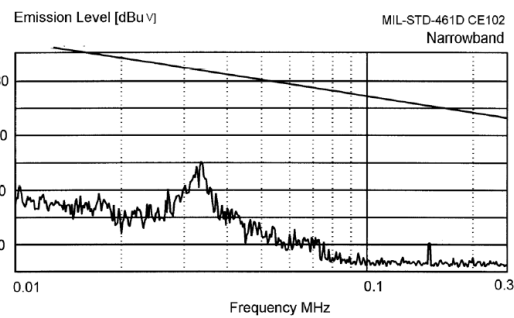
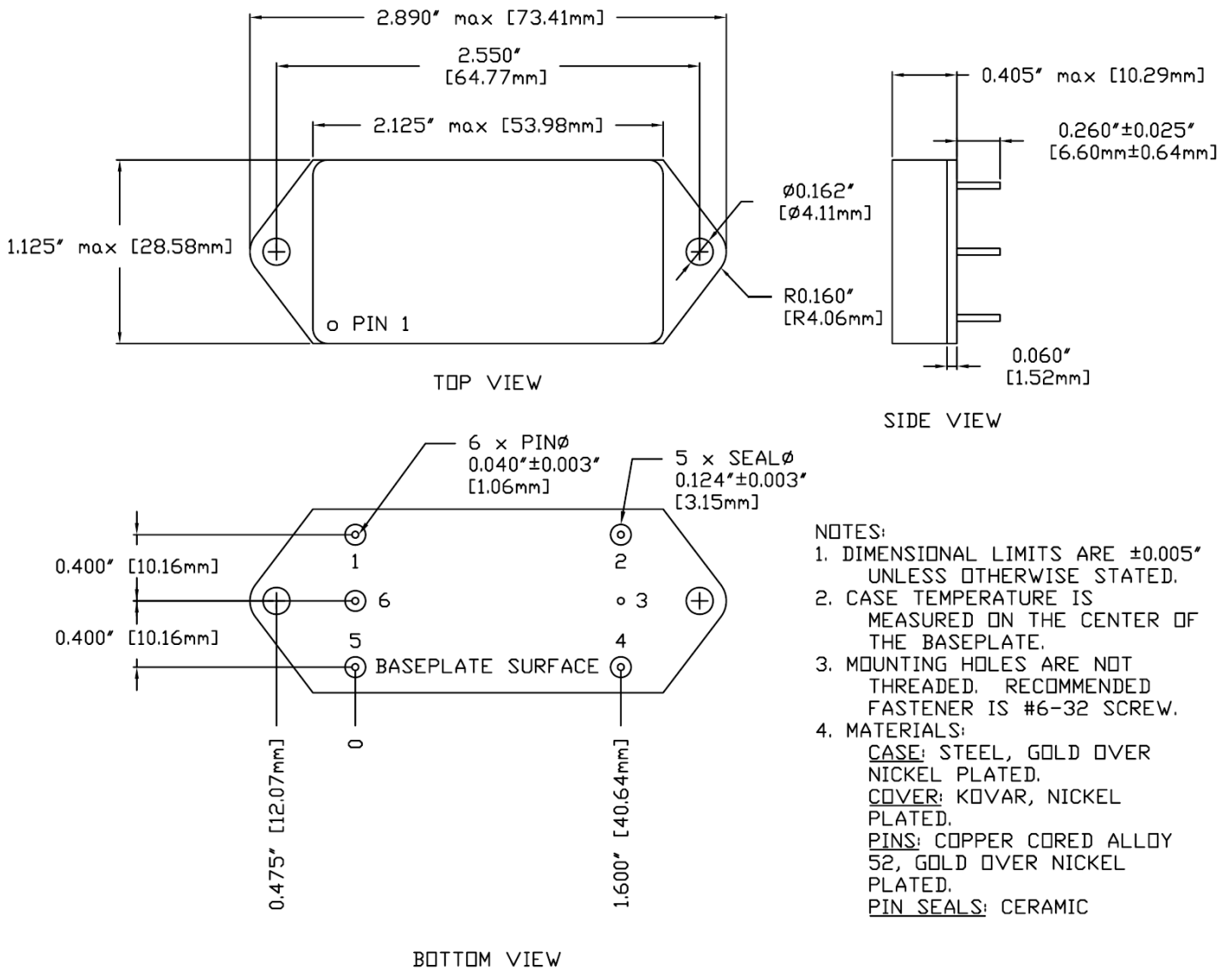

Figure 9 – MIL-STD-461D DVTR2800S With DV-704A EMI Filter

PACKAGE SPECIFICATIONS (SEAM SEAL)



Pin	Function	Pin	Function	Pin	Function
1	28V IN	3	CASE	5	IN COM
2	28V OUT	4	OUT COM	6	INHIBIT

Figure 11 – Seam Seal Package and Pinout

PACKAGE PIN DESCRIPTION

Pin	Function	Description
1	28V IN	Positive Input Voltage Connection
2	28V OUT	Positive Output Voltage Connection
3	CASE	Case Connection
4	OUT COM	Output Common Connection
5	IN COM	Input Common Connection
6	INHIBIT	Logic Low = Disabled Output. Connecting the inhibit pin to input common causes filter shutdown. Logic High = Enabled Output. Unconnected or open collector TTL.

ENVIRONMENTAL SCREENING (100% Tested Per MIL-STD-883 as referenced to MIL-PRF-38534)

Screening	MIL-STD-883	Standard (No Suffix)	Extended /ES	HB /HB	Class H /H	Class K /K
Non-Destructive Bond Pull	Method 2023	•	•	•	•	•
Internal Visual	Method 2017, 2032 Internal Procedure	•	•	•	•	•
Temperature Cycling	Method 1010, Condition C Method 1010, -55°C to 125°C		•	•	•	•
Constant Acceleration	Method 2001, 3000g, Y1 Direction Method 2001, 500g, Y1 Direction		•	•	•	•
PIND	Method 2020, Condition A ²					•
Pre Burn-In Electrical	100% at 25°C					•
Burn-In	Method 1015, 320 hours at +125°C Method 1015, 160 hours at +125°C 96 hours at +125°C 24 hours at +125°C	•	•	•	•	•
Final Electrical	MIL-PRF-38534, Group A ¹ 100% at 25°C	•	•	•	•	•
Hermeticity	Method 1014, Fine Leak, Condition A Method 1014, Gross Leak, Condition C Dip (1 x 10 ⁻³)	•	•	•	•	•
Radiography	Method 2012 ³					•
External Visual	Method 2009	•	•	•	•	•

- Notes:
1. 100% R&R testing at -55°C, +25°C, and +125°C with all test data included in product shipment.
 2. PIND test Certificate of Compliance included in product shipment.
 3. Radiographic test Certificate of Compliance and film(s) included in product shipment.

ORDERING INFORMATION

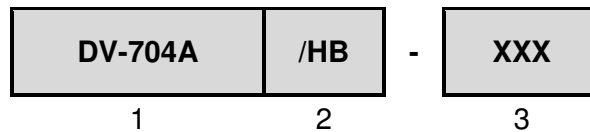

(1)

(2)

(3)

Product Series	Screening Code ^{1, 2}		Additional Screening Code
DV-704A	None /ES /HB /H /K	Standard Extended HB Class H Class K	Contact Sales

- Notes:
1. Contact the VPT Inc. Sales Department for availability of Class H (/H) or Class K (/K) qualified products.
 2. VPT Inc. reserves the right to ship higher screened or SMD products to meet lower screened orders at our sole discretion unless specifically forbidden by customer contract.

Please contact your sales representative or the VPT Inc. Sales Department for more information concerning additional environmental screening and testing, different input voltage, output voltage, power requirement, source inspection, and/or special element evaluation for space or other higher quality applications.

SMD (STANDARD MICROCIRCUIT DRAWING) NUMBERS

Standard Microcircuit Drawing (SMD)	DV-704A Series Similar Part Number
*T.B.D.	DV-704A/H

Do not use the DV-704A Series similar part number for SMD product acquisition. It is listed for reference only. For exact specifications for the SMD product, refer to the SMD drawing. SMD's can be downloaded from the DLA Land and Maritime (Previously known as DSCC) website at <https://landandmaritimeapps.dla.mil/programs/defaultapps.asp>. The SMD number listed above is for MIL-PRF-38534 Class H screening, standard gold plated lead finish, and no RHA (Radiation Hardness Assurance) level. Please reference the SMD for other screening levels, lead finishes, and radiation levels. All SMD products are marked with a "Q" on the cover as specified by the QML certification mark requirement of MIL-PRF-38534.

CONTACT INFORMATION

To request a quotation or place orders please contact your sales representative or the VPT Inc. Sales Department at:

Phone: (425) 353-3010
Fax: (425) 353-4030
E-mail: vptsales@vpt-inc.com

All information contained in this datasheet is believed to be accurate, however, no responsibility is assumed for possible errors or omissions. The products or specifications contained herein are subject to change without notice.