



256Kx32 Synchronous Pipeline Burst SRAM 3.3V



FEATURES

- tKH0V times of 3.5, 3.8 and 4.0ns
- 166, 150 and 133 MHz clock speed
- DSP Memory Solution
 - Texas Instruments' TMS320C6201
 - Texas Instruments' TMS320C67x
- Package:
 - 119 pin BGA, JEDEC MO-163
- 3.3V Operating Supply Voltage
- 3.5ns Output Enable access time
- Single Write Control and Output Enable Lines
- Single Chip Enable Line
- 56% space savings vs. monolithic TQFPs
- Multiple VCC and VSS pins
- Reduced inductance and capacitance

DESCRIPTION

The EDI2DL32256VxxBC is a 3.3V, 256Kx32 Synchronous Pipeline Burst SRAM constructed with two 256Kx16 die mounted on a multi-layer laminate substrate. The device is packaged in a 119 lead, 14mm by 22mm, BGA. It is available with clock speeds of 166, 150 and 133 MHz. The device is a Pipeline Burst SRAM, allowing the user to develop a fast external memory for Texas Instruments' "C6x". In Burst Mode data from the first memory location is available in three clock cycles, while the subsequent data is available in one clock cycle (3/1/1/1). Subsequent burst addresses are generated by the TMS320C6x DSP. Individual address locations can also be read, allowing one memory access in 3 clock cycles. All synchronous inputs are gated by registers controlled by a positive-edge-triggered clock input (CLK). The synchronous inputs include all addresses, all data inputs, chip enable (CE), burst control input (ADSC), byte write enables (BW0\ to BW3) and Write Enable (BWE).

Asynchronous inputs include the output enable (OE), burst mode control (MODE), and sleep mode control (ZZ). The data outputs (DQ), enabled by OE, are also asynchronous.

Address lines and the chip enable are registered with the address status controller (ADSC) input pin.

FIG. 1

PIN CONFIGURATION

| | 1 | 2 | 3 | 4 | 5 | 6 | 7 | |
|---|------------------|------------------|-------------------|-----------------|-------------------|------------------|------------------|---|
| A | V _{DD} | A | A | NC | A | A | V _{DD} | A |
| B | NC | NC | A | ADSC\ | A | A | NC | B |
| C | NC | A | A | V _{DD} | A | A | NC | C |
| D | DQ ₁₆ | NC | V _{SS} | NC | V _{SS} | NC | DQ ₈ | D |
| E | DQ ₁₈ | DQ ₁₇ | V _{SS} | CE\ | V _{SS} | DQ ₉ | DQ ₁₀ | E |
| F | V _{DD} | DQ ₁₉ | V _{SS} | OE\ | V _{SS} | DQ ₁₁ | V _{DD} | F |
| G | DQ ₂₁ | DQ ₂₀ | BE ₂ \ | NC | BE ₁ \ | DQ ₁₂ | DQ ₁₃ | G |
| H | DQ ₂₃ | DQ ₂₂ | V _{SS} | NC | V _{SS} | DQ ₁₄ | DQ ₁₅ | H |
| J | V _{DD} | V _{DD} | NC | V _{DD} | NC | V _{DD} | V _{DD} | J |
| K | DQ ₃₁ | DQ ₃₀ | V _{SS} | CLK | V _{SS} | DQ ₆ | DQ ₇ | K |
| L | DQ ₂₉ | DQ ₂₈ | BE ₃ \ | NC | BE ₀ \ | DQ ₄ | DQ ₅ | L |
| M | V _{DD} | DQ ₂₇ | V _{SS} | BWE\ | V _{SS} | DQ ₃ | V _{DD} | M |
| N | DQ ₂₆ | DQ ₂₅ | V _{SS} | A ₁ | V _{SS} | DQ ₁ | DQ ₂ | N |
| P | DQ ₂₄ | NC | V _{SS} | A ₀ | V _{SS} | NC | DQ ₀ | P |
| R | NC | A | MODE | V _{DD} | NC | A | NC | R |
| T | NC | NC | A | A | A | NC | ZZ | T |
| U | V _{DD} | NC | NC | NC | NC | NC | V _{DD} | U |
| | 1 | 2 | 3 | 4 | 5 | 6 | 7 | |

BLOCK DIAGRAM

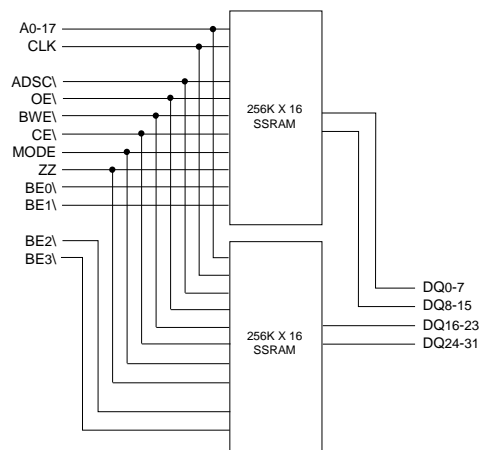



PIN DESCRIPTIONS

| Pin | Symbol | Type | Description |
|----------------|-------------------------|-------------------|---|
| Various | A0-17 | Input Synchronous | Addresses: These inputs are registered and must meet setup and hold times around the rising edge of CLK. |
| L5,G5 G3,L3 | BE0\,BE1\, BE2\,BE3\ | Input Synchronous | Byte Write: A byte write is LOW for a WRITE cycle and HIGH for a READ BE2\, BE3\ cycle. BE0\ controls DQ0-7. BE1\ controls DQ8-15. BE2\ controls DQ16-23. BE3\ controls DQ24-31 |
| M4 | BWE\ | Input Synchronous | Byte Write Enable: This active LOW input gates byte write operations and must meet the setup and hold times around the rising edge of CLK. |
| K4 | CLK | Input Synchronous | Clock: This signal registers the addresses, data, chip enables, write control and burst control inputs on its rising edge. All synchronous inputs must meet setup and hold times around the clock's rising edge. |
| E4 | CE\ | Input Synchronous | Chip Enable: This active LOW inputs is used to enable the device. |
| F4 | OE\ | Input | Output Enable: This active LOW asynchronous input enables the data output drivers |
| B4 | ADSC\ | Input Synchronous | Address Status Controller: This active LOW input causes device to be deselected or selected along with new external address to be registered. A READ or WRITE cycle is initiated depending upon write control inputs. |
| R3 | MODE | Input | Static Mode: This input selects the burst sequence. A LOW on this pin selects LINEAR BURST. A NC or HIGH on this pin selects INTERLEAVED BURST. |
| T7 | ZZ | Input Synchronous | Snooze: This active HIGH input puts the device in low power consumption standby mode. For normal operation, this input has to be either LOW or NC (no connect) |
| Various | DQ0-31 | Input/Output | Data Inputs/Outputs: First byte is DQ0-7, second byte is DQ8-15, third byte is DQ16-23, fourth byte is DQ24-31 |
| Various | Vcc | Supply | Core power supply: +3.3V -5%/+5% |
| Various | Vss | Ground | Ground |

TRUTH TABLE

| Operation | Address Used | CE\ | ADSC\ | WRITE\ | OE\ | DQ |
|------------------------------|--------------|-----|-------|--------|-----|--------|
| Deselected Cycle, Power Down | None | H | L | X | X | High-Z |
| WRITE Cycle, Begin Burst | External | L | L | L | X | D |
| READ Cycle, Begin Burst | External | L | L | H | L | Q |
| READ Cycle, Begin Burst | External | L | L | H | H | High-Z |
| READ Cycle, Suspend Burst | Current | X | H | H | L | Q |
| READ Cycle, Suspend Burst | Current | X | H | H | H | High-Z |
| READ Cycle, Suspend Burst | Current | H | H | H | L | Q |
| READ Cycle, Suspend Burst | Current | H | H | H | H | High-Z |
| WRITE Cycle, Suspend Burst | Current | X | H | L | X | D |
| WRITE Cycle, Suspend Burst | Current | H | H | L | X | D |

NOTE:

- X means idonit carei, H means logic HIGH. L means logic LOW.
- 2a. WRITE\ = L, means [BE0*BE1*BE2*BE3\]*BWE\ equals LOW
2b. WRITE\ = H, means [BE0*BE1*BE2*BE3\]*BWE\ equals HIGH
3. All inputs except OE\ must meet setup and hold times around the rising edge (LOW to HIGH) of CLK.
4. Suspending burst generates wait cycle
5. For a write operation following a read operation, OE\ must be HIGH before the input data required setup time plus High-Z time for OE\ and staying HIGH though out the input data hold time.
6. This device contains circuitry that will ensure the outputs will be in High-Z during power-up.



ABSOLUTE MAXIMUM RATINGS*

| | |
|--|--------------------------------|
| Voltage on Vcc Supply Relative to Vss | -0.5V to 4.6V |
| V _{IN} | -0.5V to V _{CC} +0.5V |
| Storage Temperature | -55°C to +110°C |
| Junction Temperature | +110°C |
| Power Dissipation | 3 Watts |
| Short Circuit Output Current (per I/O) | 20 mA |

* Stresses greater than those listed under "Absolute Maximum Ratings" may cause permanent damage to the device. This is a stress rating only and functional operation of the device at these or any other conditions greater than those indicated in the operational sections of this specification is not implied. Exposure to absolute maximum rating conditions for extended periods may affect reliability.

RECOMMENDED OPERATING CONDITIONS

| Description | Symbol | Min | Max | Unit |
|--------------------|-----------------|-------|----------------------|------|
| Input High Voltage | V _{IH} | 2 | V _{CC} +0.3 | V |
| Input Low Voltage | V _{IL} | -0.3 | 0.7 | V |
| Supply Voltage | V _{CC} | 3.135 | 3.465 | V |

CAPACITANCE

(f = 1MHz, V_{IN} = V_{CC} or V_{SS})

| Parameter | Symbol | Max | Unit |
|---------------|------------------|-----|------|
| Address Lines | C _A | TBD | pF |
| Data Lines | C _{D/Q} | TBD | pF |
| Control Lines | C _C | TBD | pF |

PARTIAL TRUTH TABLE

| Function | BWE\ | BE0\ | BE1\ | BE2\ | BE3 |
|-------------------------------------|------|------|------|------|-----|
| READ | H | X | X | X | X |
| WRITE one Byte (DQ ₀₋₇) | L | L | H | H | H |
| WRITE all Bytes | L | L | L | L | L |

DC ELECTRICAL CHARACTERISTICS

(f = 1MHz, V_{IN} = V_{CC} or V_{SS})

| Parameter | Symbol | Conditions | Min | Max | Units |
|---------------------------------|------------------|---|-----|-----|-------|
| Power Supply Current: Operating | I _{CC1} | Device Selected; all inputs ≤ V _{IL} or ≥ V _{IH} ; cycle time ≥ t _{CK} MIN; V _{CC} = MAX; outputs open | | 850 | mA |
| CMOS Standby | I _{SB2} | Device deselected; V _{CC} = MAX; all inputs ≤ V _{SS} +0.2 or ≥ V _{CC} -0.2; all inputs static; CLK frequency = 0 | | 20 | mA |
| TTL Standby | I _{SB3} | Device deselected; all inputs ≤ V _{IL} or ≥ V _{IH} ; all inputs static; V _{CC} = MAX; CLK frequency = 0 | | 40 | mA |
| TTL Standby | I _{SB4} | Device deselected; all inputs ≤ V _{IL} or ≥ V _{IH} ; V _{CC} = MAX; CLK cycle time ≥ t _{CK} MIN | | 40 | mA |
| Input Leakage Current | I _{LI} | 0V < V _{IN} < V _{CC} | -2 | 2 | μA |
| Output Leakage Current | I _{LO} | Output(s) disabled, 0V ≤ V _{OUT} ≤ V _{CC} | -2 | 2 | μA |
| Output High Voltage | V _{OH} | I _{OH} = -2.0mA | 2.4 | | V |
| Output Low Voltage | V _{OL} | I _{OL} = 2.0mA | | 0.7 | V |

AC TEST CIRCUIT

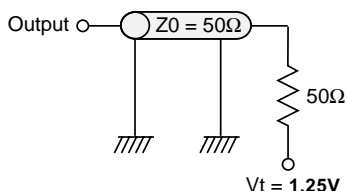

AC Output Load Equivalent

AC TEST CONDITIONS

| Parameter | I/O | Unit |
|---------------------------------|------------------------|------|
| Input Pulse Levels | V _{SS} to 2.5 | V |
| Input Rise and Fall Times (max) | 1.8 | ns |
| Input and Output Timing Levels | 1.25 | V |
| Output Load | See figure, at left | |



AC ELECTRICAL CHARACTERISTICS

| Description | Symbol | 3.5ns | | 3.8ns | | 4.0ns | | Units |
|--|--------------------|-------|-----|-------|-----|-------|-----|-------|
| | | Min | Max | Min | Max | Min | Max | |
| Clock | | | | | | | | |
| Clock cycle time | t _{KHKH} | 6 | | 6.7 | | 7.5 | | |
| Clock HIGH time | t _{KHKL} | 2.4 | | 2.6 | | 2.8 | | |
| Clock LOW time | t _{KLKH} | 2.4 | | 2.6 | | 2.8 | | |
| Output Times | | | | | | | | |
| Clock to output valid | t _{KHOV} | | 3.5 | | 3.8 | | 4.0 | |
| Clock to output in Low-Z | t _{KHOX} | 0 | | 0 | | 0 | | |
| Clock to output in High-Z | t _{KHOZ} | 1.5 | 6 | 1.5 | 6.7 | 1.5 | 7.5 | |
| OE to output valid | t _{OELQV} | | 3.5 | | 3.5 | | 3.8 | |
| OE to output in Low-Z | t _{OELQX} | 0 | | 0 | | 0 | | |
| OE to output in High-Z | t _{OELQZ} | | 3.5 | | 3.5 | | 3.8 | |
| Setup Times | | | | | | | | |
| Address Status Controller valid to Clock | t _{SCVKH} | 1.5 | | 1.5 | | 1.5 | | |
| Address valid to Clock | t _{AVKH} | 1.5 | | 1.5 | | 1.5 | | |
| Chip Enable valid to Clock | t _{EVKH} | 1.5 | | 1.5 | | 1.5 | | |
| Write Enable (BWE) valid to Clock | t _{WLKH} | 1.5 | | 1.5 | | 1.5 | | |
| Data Valid to Clock | t _{DVKH} | 1.5 | | 1.5 | | 1.5 | | |
| Hold Times | | | | | | | | |
| Address Status Controller Hold time | t _{KHSCX} | 0.5 | | 0.5 | | 0.5 | | |
| Address Hold time | t _{KHAX} | 0.5 | | 0.5 | | 0.5 | | |
| Chip Enable Hold time | t _{KHEX} | 0.5 | | 0.5 | | 0.5 | | |
| Write Enable (BWE) Hold time | t _{KHWX} | 0.5 | | 0.5 | | 0.5 | | |
| Data Hold time | t _{KHDX} | 0.5 | | 0.5 | | 0.5 | | |



FIG. 2 READ TIMING

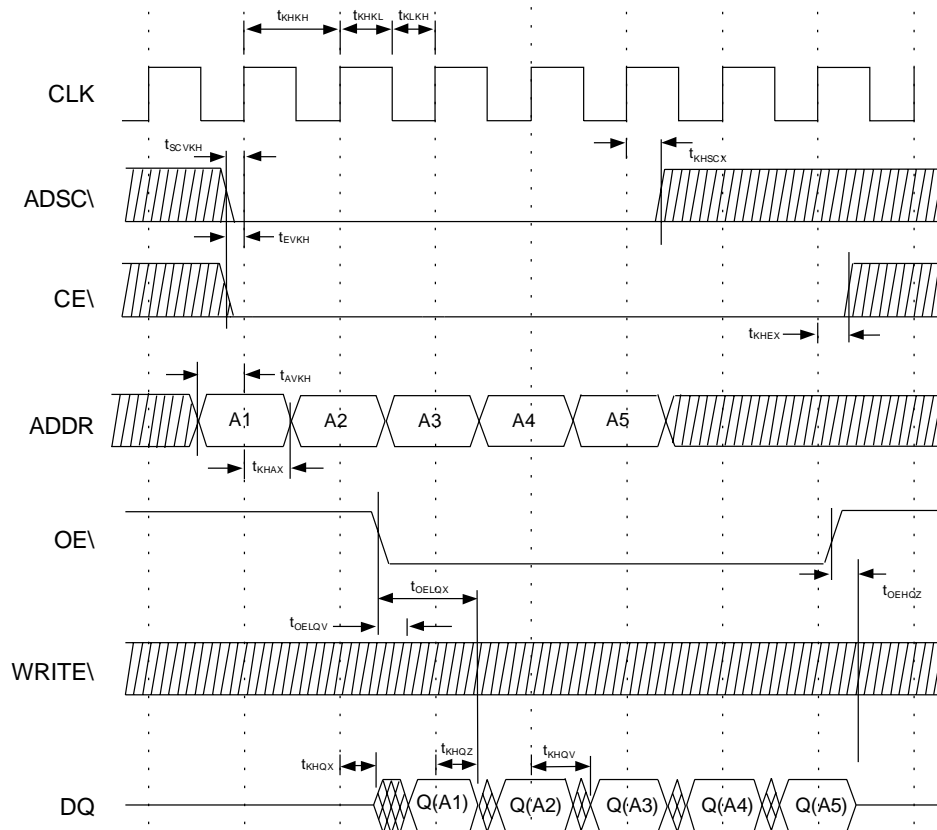
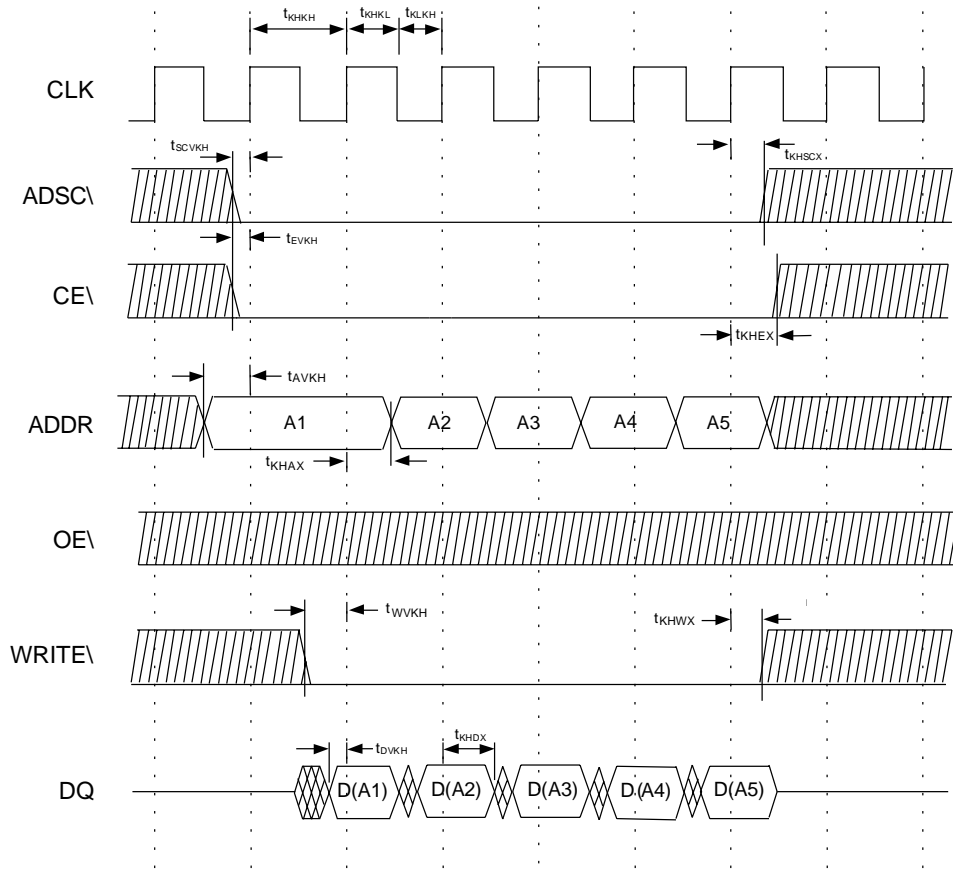



FIG. 3 WRITE TIMING





ORDERING INFORMATION

| Commercial Temperature Range (0°C to +70°C) | | | |
|---|----------------------|-----------------------|-------------|
| Part Number | τ _{κQ} (ns) | Clock Frequency (MHz) | Package No. |
| EDI2DL32256V35BC | 3.5 | 166 | TBD |
| EDI2DL32256V38BC | 3.8 | 150 | TBD |
| EDI2DL32256V40BC | 4.0 | 133 | TBD |

| Industrial Temperature Range (-40°C to +85°C) | | | |
|---|----------------------|-----------------------|-------------|
| Part Number | τ _{κQ} (ns) | Clock Frequency (MHz) | Package No. |
| EDI2DL32256V40BI | 4.0 | 133 | TBD |

**PACKAGE DESCRIPTION: 119 LEAD BGA
JEDEC MO-163**

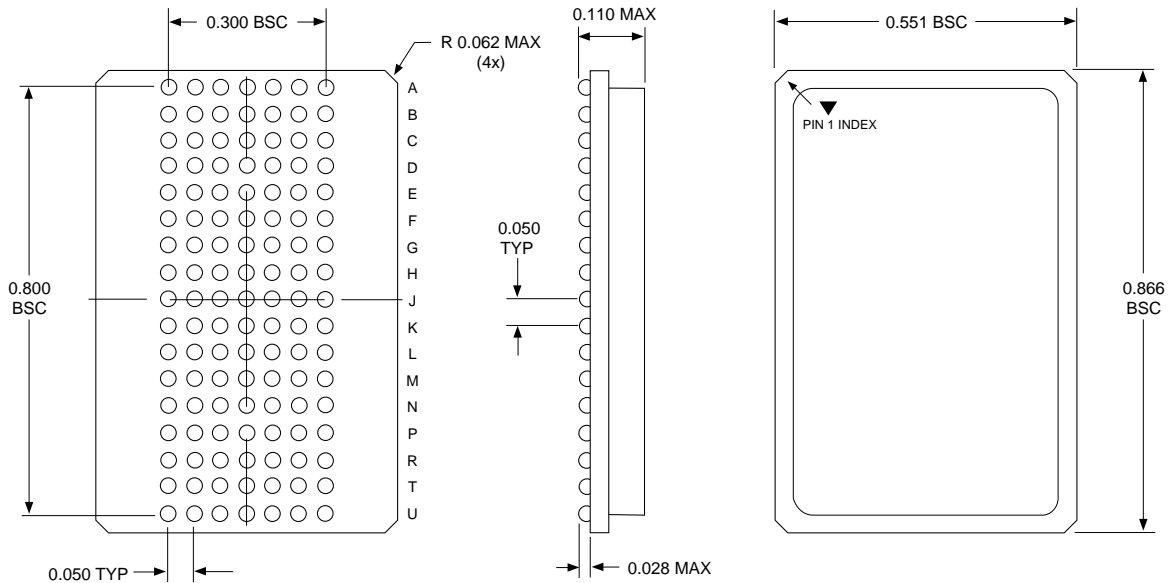

ALL DIMENSIONS ARE IN INCHES



FIG. 5
INTERFACING THE TEXAS INSTRUMENTS TMS320C6201
WITH THE EDI2DL32256V (256Kx32 SSRAM)

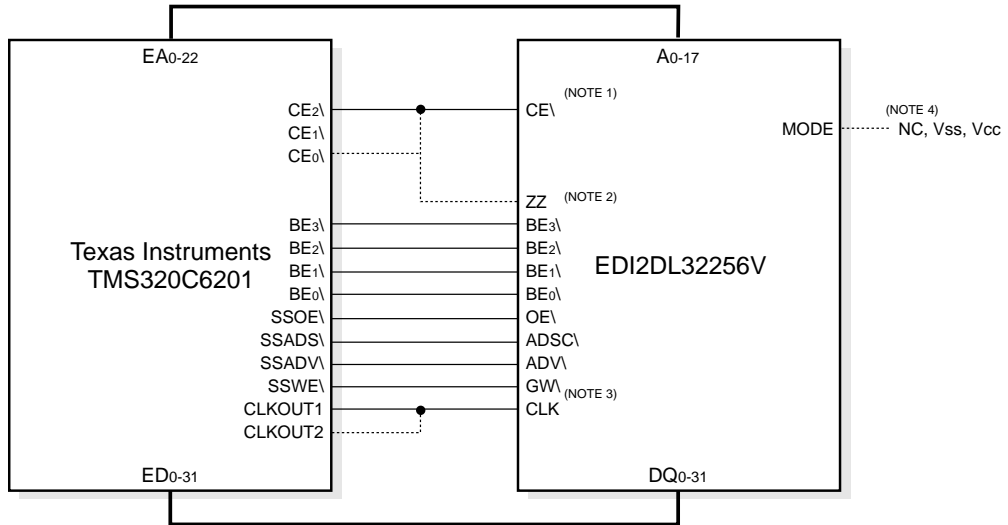

NOTES:

1. Either \overline{CE}_0 or \overline{CE}_2 can be used to enable the device.
2. When the ZZ pin is asserted HIGH, the device will be in CMOS standby mode regardless of the state of any other pins. While in standby mode the device will take one complete Clock cycle to become active again after a LOW is asserted on the ZZ pin. One possible option for the designer concerned about power is to tie the ZZ signal to the chip enable they are using for the device. Any time the chip is disabled (by driving the chip enable pin HIGH) the device will go into standby mode. Standby mode can also be achieved by tying the ZZ pin LOW or allowing it to float and meeting all the signal conditions specified in the data sheet.
3. Use CLKOUT1 for running the memory at the same clock speed as the C6x. Use CLKOUT2 for running the SBSRAM at one half the clock rate of the C6x.
4. The MODE pin can be tied to Vss (Linear Burst), tied to Vcc (Interleaved Burst) or allowed to float (Interleaved Burst).