

EH13 Series

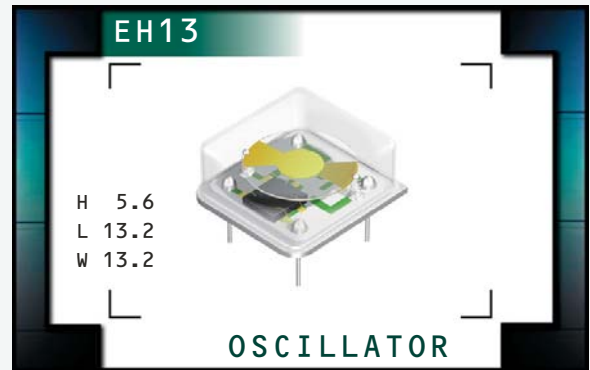

ECLIPTEK[®]
CORPORATION

- RoHS Compliant (Pb-free)
- HCMOS Output
- 3.3V Supply Voltage
- 8 Pin DIP Package
- Stability to 20ppm
- Custom Lead Length and Gull Wing Options Available



NOTES

ELECTRICAL SPECIFICATIONS

Frequency Range		1.000MHz to 155.520MHz
Operating Temperature Range		0°C to 70°C or -40°C to 85°C
Storage Temperature Range		-55°C to 125°C
Supply Voltage (V_{DD})		3.3V _{DC} ±0.3V _{DC}
Input Current		35mA Maximum (Unloaded)
Frequency Tolerance / Stability	Inclusive of all conditions: Calibration Tolerance at 25°C, Frequency Stability over the Operating Temperature Range, Supply Voltage Change, Output Load Change, First Year Aging at 25°C, Shock, and Vibration	±100ppm, ±50ppm, ±25ppm, or ±20ppm Maximum
Output Voltage Logic High (V_{OH})		2.7V _{DC} Minimum I _{OH} = -8mA
Output Voltage Logic Low (V_{OL})		0.5V _{DC} Maximum I _{OL} = +8mA
Rise Time / Fall Time	≤70.000MHz 20% to 80% of Waveform w/HCMOS Load >70.000MHz 20% to 80% of Waveform w/HCMOS Load	6 nSeconds Maximum 4 nSeconds Maximum
Load Drive Capability	≤70.000MHz >70.000MHz	30pF HCMOS Load Maximum 15pF HCMOS Load Maximum
Duty Cycle (at V_{DD}=3.3V_{DC})	at 50% of Waveform	50 ±10(%) (Standard) or 50 ±5(%) (Optional)
Tri-State Input Voltage	V _{IH} : No Connection or ≥2.2V _{DC} V _{IL} : ≤0.8V _{DC}	Enables Output Disables Output: High Impedance
Aging (at 25°C)		±5ppm / year Maximum
Start Up Time		10mSeconds Maximum
Period Jitter: Absolute		±250pSec Maximum, ±100pSec Typical
Period Jitter: One Sigma		±50pSec Maximum, ±40pSec Typical

MANUFACTURER
ECLIPTEK CORP.

CATEGORY
OSCILLATOR

SERIES
EH13

PACKAGE
8 pin DIP

VOLTAGE
3.3V

CLASS
OS45

REV. DATE
08/05

PART NUMBERING GUIDE

EH13 00 HS ET TS - 70.000M - G TR

FREQUENCY TOLERANCE / STABILITY

00=±100ppm Maximum (Standard)
 45=±50ppm Maximum, 25=±25ppm Maximum
 20=±20ppm Maximum

PACKAGE

HS=Half Size 8 Pin DIP

OPERATING TEMP. RANGE

Blank=0°C to 70°C (Standard), ET=-40°C to 85°C

DUTY CYCLE

Blank=50 ±10(%) (Standard), T=50 ±5(%)

PACKAGING OPTIONS

Blank=Bulk (Standard)
 TR=Tape & Reel (only offered with
 Half Size G and Half Size G2 Options)

AVAILABLE OPTIONS

Blank=None (Standard)
 CLXXX=Custom Lead Length (See Page 133)
 G=Half Size Gull Wing (See Page 132)
 G2=Half Size Gull Wing (See Page 132)

FREQUENCY

OUTPUT CONTROL FUNCTION

TS=Tri-State Enable High

MECHANICAL DIMENSIONS ALL DIMENSIONS IN MILLIMETERS

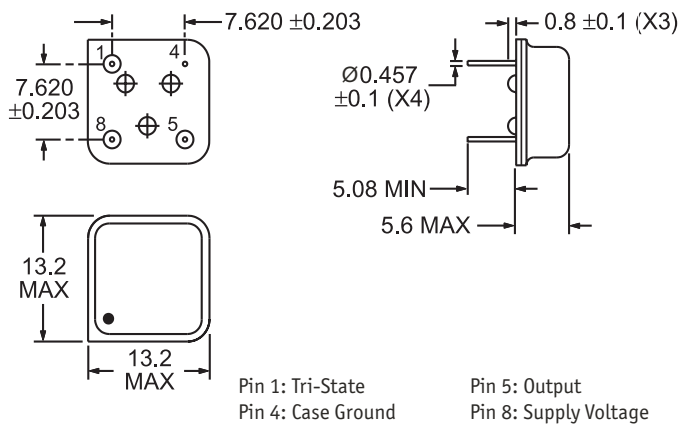

TAPE AND REEL DIMENSIONS ALL DIMENSIONS IN MILLIMETERS

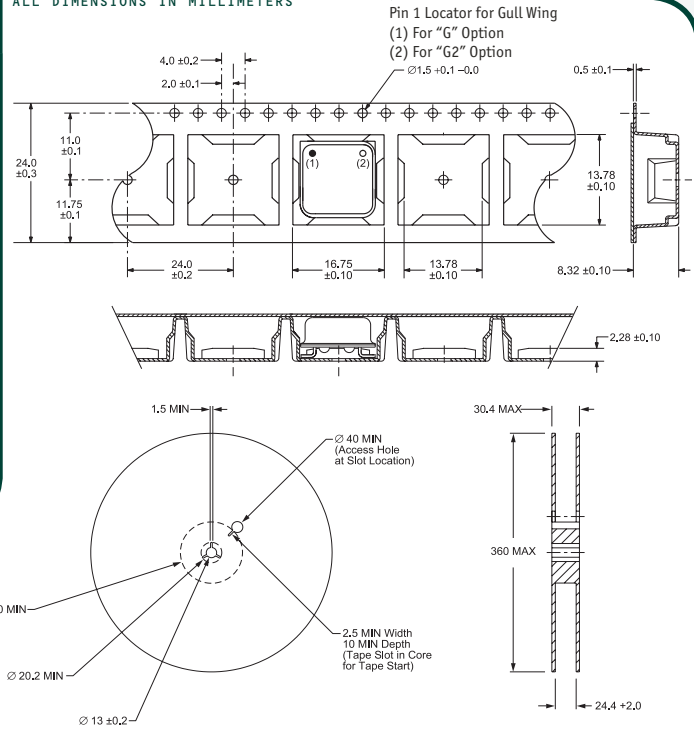

MARKING SPECIFICATIONS

Line 1: ECLIPTEK
 Line 2: EH13 TS — Series Designator
 Line 3: XX.XXX M — Frequency in MHz (5 Digits Maximum + Decimal)
 Line 4: XX Y ZZ — Week of Year, Last Digit of Year, Eclipsetek Manufacturing Identifier

Note: Pin 1 shall be designated with a dot

ENVIRONMENTAL/MECHANICAL SPECIFICATIONS

Characteristic	Specification
Fine Leak Test	MIL-STD-883, Method 1014, Condition A
Gross Leak Test	MIL-STD-883, Method 1014, Condition C
Mechanical Shock	MIL-STD-202, Method 213, Condition C
Vibration	MIL-STD-883, Method 2007, Condition A
Lead Integrity	MIL-STD-883, Method 2004
Solderability	MIL-STD-883, Method 2002
Temperature Cycling	MIL-STD-883, Method 1010
Resistance to Soldering Heat	MIL-STD-883, Method 210
Resistance to Solvents	MIL-STD-883, Method 215

MANUFACTURER	CATEGORY	SERIES	PACKAGE	VOLTAGE	CLASS	REV. DATE
ECLIPTEK CORP.	OSCILLATOR	EH13	8 pin DIP	3.3V	OS45	08/05