

---

**eKM6211**

**RF Mouse Rx Controller**

**Product  
Specification**

**DOC. VERSION 1.0**

**ELAN MICROELECTRONICS CORP.**

November 2003

PRELIMINARY

---



**Trademark Acknowledgments:**

**IBM is a registered trademark and PS/2 is a trademark of IBM.**

**Windows is a trademark of Microsoft Corporation.**

**ELAN and ELAN logo  are trademarks of ELAN Microelectronics Corporation.**

Copyright © 2005 by ELAN Microelectronics Corporation

**All Rights Reserved**

Printed in Taiwan

The contents of this specification are subject to change without further notice. ELAN Microelectronics assumes no responsibility concerning the accuracy, adequacy, or completeness of this specification. ELAN Microelectronics makes no commitment to update, or to keep current the information and material contained in this specification. Such information and material may change to conform to each confirmed order.

In no event shall ELAN Microelectronics be made responsible for any claims attributed to errors, omissions, or other inaccuracies in the information or material contained in this specification. ELAN Microelectronics shall not be liable for direct, indirect, special incidental, or consequential damages arising from the use of such information or material.

The software (if any) described in this specification is furnished under a license or nondisclosure agreement, and may be used or copied only in accordance with the terms of such agreement.

ELAN Microelectronics products are not intended for use in life support appliances, devices, or systems. Use of ELAN Microelectronics product in such applications is not supported and is prohibited.

**NO PART OF THIS SPECIFICATION MAY BE REPRODUCED OR TRANSMITTED IN ANY FORM OR BY ANY MEANS WITHOUT THE EXPRESSED WRITTEN PERMISSION OF ELAN MICROELECTRONICS.**



**ELAN MICROELECTRONICS CORPORATION**

**Headquarters:**

No. 12, Innovation Road 1  
Hsinchu Science Park  
Hsinchu, Taiwan 30077  
Tel: +886 3 563-9977  
Fax: +886 3 563-9966  
<http://www.emc.com.tw>

**Hong Kong:**

**Elan (HK) Microelectronics Corporation, Ltd.**  
Rm. 1005B, 10/F Empire Centre  
68 Mody Road, Tsimshatsui  
Kowloon, HONG KONG  
Tel: +852 2723-3376  
Fax: +852 2723-7780  
[elanhk@emc.com.hk](mailto:elanhk@emc.com.hk)

**USA:**

**Elan Information Technology Group**  
1821 Saratoga Ave., Suite 250  
Saratoga, CA 95070  
USA  
Tel: +1 408 366-8223  
Fax: +1 408 366-8220

**Europe:**

**Elan Microelectronics Corp. (Europe)**  
Siewerdtstrasse 105  
8050 Zurich, SWITZERLAND  
Tel: +41 43 299-4060  
Fax: +41 43 299-4079  
<http://www.elan-europe.com>

**Shenzhen:**

**Elan Microelectronics Shenzhen, Ltd.**  
SSMEC Bldg., 3F, Gaoxin S. Ave.  
Shenzhen Hi-Tech Industrial Park  
Shenzhen, Guangdong, CHINA  
Tel: +86 755 2601-0565  
Fax: +86 755 2601-0500

**Shanghai:**

**Elan Microelectronics Shanghai Corporation, Ltd.**  
23/Bldg. #115 Lane 572, Bibo Road  
Zhangjiang Hi-Tech Park  
Shanghai, CHINA  
Tel: +86 021 5080-3866  
Fax: +86 021 5080-4600



# Contents

<b>1</b>	<b>General Descriptor</b> .....	<b>1</b>
<b>2</b>	<b>Feature</b> .....	<b>1</b>
<b>3</b>	<b>Application</b> .....	<b>1</b>
<b>4</b>	<b>Pin Assignment</b> .....	<b>2</b>
<b>5</b>	<b>Pin Descriptor</b> .....	<b>2</b>
<b>6</b>	<b>Function Descriptor</b> .....	<b>3</b>
6.1	Legacy PS/2 Mouse Operating .....	3
6.1.1	Operating Mode.....	3
6.1.2	PS/2 Mouse Data Report .....	4
6.1.3	PS/2 Mouse Data Transmission.....	4
6.1.4	PS/2 Mouse Error Handling .....	5
6.1.5	PS/2 Mouse Commands Description .....	6
6.2	Microsoft PS/2 Scrolling Mouse Mode.....	9
6.2.1	Entering Procedure .....	9
6.2.2	Operating.....	9
6.2.3	Exiting Microsoft Scrolling Mode .....	10
6.3	Microsoft PS/2 IntelliMouse Mode .....	10
6.3.1	Entering Procedure .....	10
6.3.2	Operating.....	10
6.3.3	Exiting Microsoft IntelliMouse Mode.....	11
<b>7</b>	<b>Application Circuit</b> .....	<b>11</b>

PRELIMINARY



### Specification Revision History

Doc. Version	Revision Description	Date
1.0	Preliminary version	2003/11/15

PRELIMINARY

---

## 1 General Descriptor

The eKM6211 is standard RF Mouse Receiver (Rx) Controller for PS/2 compatible interface. It's receives the RF packet data from RF Rx module (circuits). And decode the RF packet data and transmitting the data to PC by PS/2 interface. The eKM6211 have two way to set device ID, it's DIP switch select and EEPROM(93C46) to storage. It's have built-in RF signal sampling and noise immunity function to improve the RF data decode efficiency.

---

## 2 Feature

- Operating voltage: 2.5V~5.5V
- Built-in regulator to generate 3.3V
- Operating frequency: 4.00Mhz
- Support PS/2 compatible interface.
- Device ID:
  - DIP switch to select 8 sets ID
  - EEPROM interface to storage 255 sets Device ID
- Support a LED to display RF packet receive status and ID set mode.
- Using jump connect to set Device ID into default ID.
- To match with RF Mouse Tx controller:
  - eKM6611 series : RF Mouse Tx
  - eKM6711 : Optical RF Mouse Tx
- Package:
  - 16 pin DIP and SOP (300mil)

---

## 3 Application

- PS/2 RF Mouse Rx

## 4 Pin Assignment

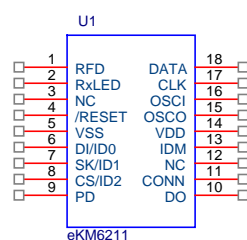

## 5 Pin Descriptor

Pin No.	Symbol	I/O	Function
1	RFD	I	RF data input
2	RxLED	O	Rx LED output
3	NC	-	NC
4	/RESET	I	Reset pin
5	VSS	-	Ground pin
6	DI/ID0	I/O	EEPROM DI pin, DIP switch ID0
7	SK/ID1	I/O	EEPROM SK pin, DIP switch ID1
8	CS/ID2	I/O	EEPROM CS pin, DIP switch ID2
9	PD	I	Plug-in detect
10	DO	I	EEPROM DO pin
11	CONN	I	Connect pin
12	NC	-	NC
13	IDM	I	ID mode select, Ground= EEPROM ID, other is DIP switch
14	VDD	-	Power supply pin
15	OSCO	O	Crystal oscillator clock output pin
16	OSCI	I	External crystal input pin
17	CLK	I/O	PS/2 CLK line
18	DATA	I/O	PS/2 Data line

## 6 Function Descriptor

### 6.1 Legacy PS/2 Mouse Operating

#### 6.1.1 Operating Mode

There are four operating modes in PS/2 mouse:

##### 6.1.1.1 Reset Mode

In this mode a self-test is initiated during power-on or by a Reset command. After reset signal, PS/2 mouse will

- (1) Send completion code AA & ID code 00.
- (2) Set default:

Sampling rate: 100 reports/s

Non-auto-speed

Stream mode

2 dot/count

Disable

##### 6.1.1.2 Stream Mode

The maximum rate of transfer is the programmed sample rate.

Data report is transmitted if

- (1) Switch is pressed
- (2) Movement has been detect

##### 6.1.1.3 Remote Mode

Data is transmitted only in response to a Read Data command.

##### 6.1.1.4 Wrap Mode

Any byte of data sent by the system, except hex EC (Reset wrap mode) or hex FF (Reset), is returned by eKM6211.

## 6.1.2 PS/2 Mouse Data Report

### 6.1.2.1 In stream mode

A data report is sent at the end of a sample interval.

### 6.1.2.2 In remote mode

A data report is sent in response to Read Data command.

### 6.1.2.3 Data report format

Byte	Bit	Description
1	0	Left button status; 1 = pressed
	1	Right button status; 1 = pressed
	2	Middle button status; 1 = pressed
	3	Reserved
	4	X data sign; 1 = negative
	5	Y data sign; 1 = negative
	6	X data overflow; 1 = overflow
	7	Y data overflow; 1 = overflow
2	0-7	X data ( D0 - D7 )
3	0-7	Y data ( D0 - D7 )

## 6.1.3 PS/2 Mouse Data Transmission

eKM6211 generates the clocking signal when sending data to and receiving data from the system.

The system requests eKM6211 receive system data output by forcing the DATA line to an inactive level and allowing CLK line to go to an active level.

Data transmission frame:

Bit	Function
1	Start bit ( always 0 )
2-9	Data bits ( D0 - D7 )
10	Parity bit ( odd parity )
11	Stop bit ( always 1 )

Data Output (data from eKM6211 to system):

If CLK is low (inhibit status), data is no transmission. If CLK is high and DATA is low (request-to-send), data is updated. Data is received from the system and no transmission are started by eKM6211 until CLK and DATA both high. If CLK and DATA both are high, the transmission is ready. DATA is valid prior to the falling edge of CLK and beyond the rising edge of CLK. During transmission, eKM6211 check for line contention by checking for an inactive level on CLK at intervals not to exceed 100u sec.



Contention occurs when the system lowers CLK to inhibit eKM6211 output after eKM6211 has started a transmission. If this occurs before the rising edge of the tenth clock, eKM6211 internal store its data in its buffer and returns DATA and CLK to an active level. If the contention does not occur by the tenth clock, the transmission is complete. Following a transmission, the system inhibits eKM6211 by holding CLK low until it can service the input or until the system receives a request to send a response from eKM6211.

Data Input (from system to eKM6211):

The System first checks if eKM6211 is transmitting data. If eKM6211 is transmitting, the system can override the output forcing CLK to an inactive level prior to the tenth clock. If eKM6211 transmission is beyond the tenth clock, the system receives the data. If eKM6211 is not transmitting or if the system choose to override the output, the system force CLK to an inactive level for a period of not less than 100u sec while preparing for output. When the system is ready to output start bit (0), it allows CLK go to active level. If request-to-send is detected, eKM6211 clocks 11 bits. Following the tenth clock, eKM6211 checks for an active level on the DATA line, and if found, force DATA low, and clock once more. If occurs framing error, eKM6211 continue to clock until DATA is high, then clocks the line control bit and request a Resend.

When the system sends out a command or data transmission that requires a response, the system waits for eKM6211 to response before sending its next output.

#### **6.1.4 PS/2 Mouse Error Handling**

- A Resend command (FE) following receipt of an invalid input or any input with incorrect polarity.
- If two invalid inputs are received in succession, an error code of hex (FC) is send to the system.
- The counter accumulators are cleared after receiving any command except "Resend".
- eKM6211 receives a Resend command (FE), it transmits its last packet of data.
- In the stream mode "Resend" is received by eKM6211 following a 3-byte data packet transmission to the system. eKM6211 resend the 3-byte data packet prior to clearing the counter.
- A response is sent within 25 ms if
  - The system requires a response
  - An error is detected in the transmission
- If eKM6211 is in the stream mode:

- The system disables eKM6211 before issuing any command requiring a response.
- When a command requiring a response is issued by the system, another command should not be issue until either the response is received or 25 ms has passed.

### 6.1.5 PS/2 Mouse Commands Description

There are 16 valid commands that transmit between the system and eKM6211. The "FA" code is always the first response to any valid input received from the system other than a Set Wrap Mode or Resend command.

The following table lists the commands:

Hex Code	Command	Echo code
FF	Reset	FA,AA,00
FE	Resend	XX,(XX,XX)
F6	Set Default	FA
F5	Disable	FA
F4	Enable	FA
F3,XX	Set Sampling Rate	FA,FA
F2	Read Device Type	FA,00
F0	Set Remote Mode	FA
EE	Set Wrap Mode	FA
EC	Reset Wrap Mode	FA
EB	Read Data	FA,XX,XX,XX
EA	Set Stream Mode	FA
E9	Status Request	FA,XX,XX,XX
E8,XX	Set Resolution	FA,FA
E7	Set Auto-speed	FA
E6	Reset Auto-speed	FA

The following describes valid commands:

#### 6.1.5.1 Reset (FF)

eKM6211 operation:

- A Completion the reset.**
- B Transmit FA, AA, 00 to the system.**
- C Set default:**
  - Sampling rate: 100 reports/s
  - Non auto-speed
  - Stream mode
  - 2 dot/count
  - Disable

#### 6.1.5.2 Resend (FE)

- A Any time eKM6211 receives an invalid command, it returns a Resend command to the system.
- B When eKM6211 receives a Resend command, it retransmits its last packet of data. If the last packet was a Resend command, it transmits the packet just prior to the Resend command.
- C In stream mode, if a Resend command is received by eKM6211 immediately following a 3-byte data packet transmission to the system.

#### 6.1.5.3 Set Default (F6)

The command reinitializes all conditions to the power-on defaults.

#### 6.1.5.4 Disable (F5)

This command is used in the stream mode to stop transmissions from eKM6211.

#### 6.1.5.5 Enable (F4)

Begins transmissions, if in stream mode.

#### 6.1.5.6 Set Sampling Rate (F3, XX)

In the stream mode, this command set the sampling rate to the value indicated by byte hex XX, shown in following:

Second byte XX	Sample Rate
0A	10/sec
14	20/sec
28	40/sec
3c	60/sec
50	80/sec
64	100/sec
C9	200/sec

#### 6.1.5.7 Read Device Type (F2)

eKM6211 always echoes " FA, 00" following this command.

#### 6.1.5.8 Set Remote Mode (F0)

Data values are reported only in response to a Read Data command.

#### 6.1.5.9 Set Wrap Mode (EE)

Wrap mode remains until Reset (FF) or Reset Wrap Mode (EC) is received.

#### 6.1.5.10 Reset Wrap Mode (EC)

eKM6211 returns to the previous mode of operation after receiving this command.

#### 6.1.5.11 Read Data (EB)

This command is executed in either remote or stream mode. The data is transmitted even if there has been no movement since the last report or the button status is unchanged. Following a Read Data command, the registers are cleared after a data transmission.

#### 6.1.5.12 Set Stream Mode (EA)

This command sets eKM6211 in stream mode.

#### 6.1.5.13 Status Request (E9)

When this command is issued by the system, eKM6211 responds with a 3-byte status report as follows:

Byte	Bit	Description
1	0	1 = Right button pressed
	1	1 = Middle button pressed
	2	1 = Left button pressed
	3	Reserved
	4	0 = Normal speed, 1 = Auto-speed
	5	0 = Disabled, 1 = Enabled
	6	0 = Stream mode, 1 = Remote mode
	7	Reserved
2	0-7	Current resolution setting (D0 - D7)
3	0-7	Current sampling rate (D0 - D7)

#### 6.1.5.14 Set Resolution (E8, XX)

eKM6211 provides four resolutions selected by the second byte of this command as follows:

Second Byte XX	Resolution
00	8 dot/count
01	4 dot/count
02	2 dot/count
03	1 dot/count

#### 6.1.5.15 Set Auto-speed (E7)

At the end of a sample interval in the stream mode, the current X and Y data values are converted new values. The sign bits are not involved in this conversion. The conversion is only in stream mode. The relationship between the input and output count follows:

Input	Output
0	0
1	1
2	1
3	3
4	6
5	9
N(>=6)	2.0*N

#### 6.1.5.16 Reset Auto-speed (E6)

This command restores normal speed.

## 6.2 Microsoft PS/2 Scrolling Mouse Mode

### 6.2.1 Entering Procedure

Except in WRAP mode, while eKM6211 received the following consecutive command.

6.2.1.1 F3 C8---- set sampling rate 200/sec

6.2.1.2 F3 64---- set sampling rate 100/sec

6.2.1.3 F3 50---- set sampling rate 80/sec

### 6.2.2 Operating

6.2.2.1 All of the commands in legacy mode still are valid.

6.2.2.2 The ID code of read device type command (F2) will changed from "00" to be "03".

6.2.2.3 Data report will be four bytes format:

Byte	Bit	Description
1	0	Left button status; 1 = pressed
	1	Right button status; 1 = pressed
	2	Middle button status; 1 = pressed
	3	Reserved
	4	X data sign; 1 = negative
	5	Y data sign; 1 = negative
	6	X data overflow; 1 = overflow
	7	Y data overflow; 1 = overflow
2	0-7	X data (D0 - D7)
3	0-7	Y data (D0 - D7)
4	0-7	Z data (D0 - D7)

### 6.2.3 Exiting Microsoft Scrolling Mode

There are two ways to exit:

6.2.3.1 Power off.

6.2.3.2 Reset command (FF).

## 6.3 Microsoft PS/2 IntelliMouse Mode

### 6.3.1 Entering Procedure

Except in WRAP mode, while eKM6211 received the following consecutive command.

6.3.1.1 F3 C8---- set sampling rate 200/sec

6.3.1.2 F3 C8---- set sampling rate 200/sec

6.3.1.3 F3 50---- set sampling rate 80/sec

### 6.3.2 Operating

6.3.2.1 All of the commands in legacy mode still are valid.

6.3.2.2 The ID code of read device type command (F2) will changed from "00" to be "04".

6.3.2.3 Data report will be four bytes format:

Byte	Bit	Description
1	0	Left button status; 1 = pressed
	1	Right button status; 1 = pressed
	2	Middle button status; 1 = pressed
	3	Reserved
	4	X data sign; 1 = negative
	5	Y data sign; 1 = negative
	6	X data overflow; 1 = overflow
	7	Y data overflow; 1 = overflow
2	0-7	X data (D0 – D7)
3	0-7	Y data (D0 – D7)
4	0-3	Z data (D0 – D3)
	4	PreviousPage button status; 1= pressed
	5	NextPage button status; 1=pressed
	6-7	Reserved

### 6.3.3 Exiting Microsoft IntelliMouse Mode

There are two ways to exit:

#### 6.3.3.1 Power off.

#### 6.3.3.2 Reset command (FF).

## 7 Application Circuit

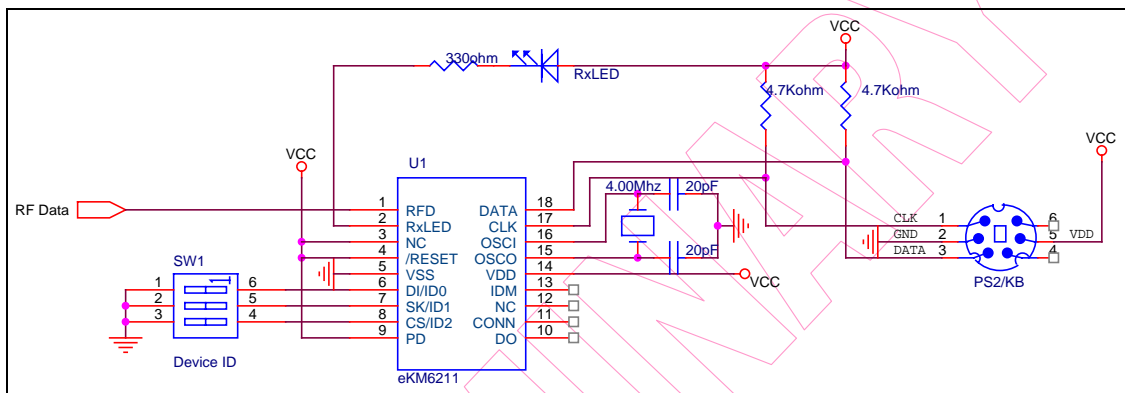

Fig.1 DIP switch ID

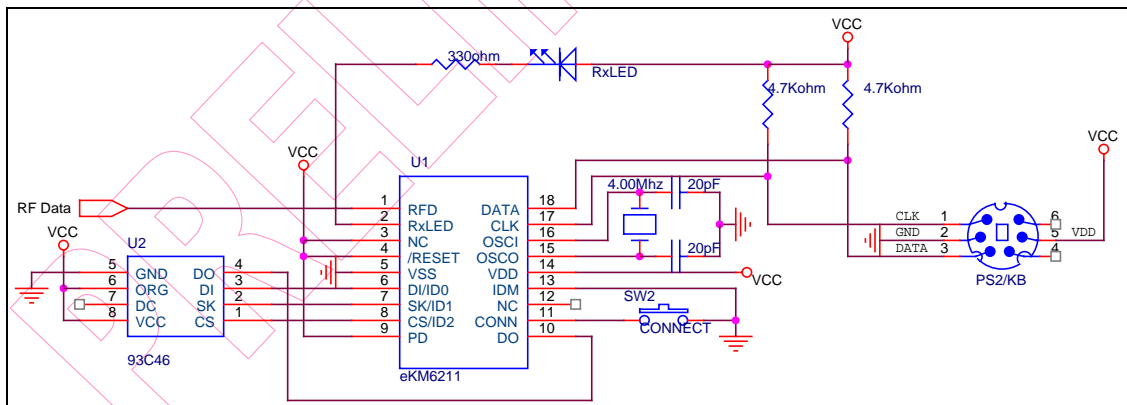

Fig.2 EEPROM ID



PRELIMINARY