



Description

The ELM380 is an 8 pin integrated circuit that is used to provide very long time interval outputs. It is typically used for enabling the charge circuit in Nickel Cadmium battery chargers, but can be easily adapted for many other applications.

An express 'one button' mode is provided on chip specifically for rechargeable battery circuits. In this mode, pressing the start button once initiates a user selectable 8 or 14 hour timing interval, after which the circuit shuts off. If one prefers, pressing that same button multiple times will allow for user programmable intervals of from 2 to 77 hours.

The circuit requires a 60Hz full-wave rectified signal for its operation. This 120Hz time base is used for all of the timekeeping functions, providing good long term stability and low cost.

Interfacing to the ELM380 is simplified by the provision of internal pull-up resistors so that the mechanical switches can be directly connected without additional components, or simply not used, depending on the application.

Applications

- Ni-Cd battery chargers
- Yard lighting or watering controls
- Houseplant grow lamp controllers

Features

- Low power CMOS design - typically 1mA at 5V
- Wide supply range - 3.0 to 5.5 volt operation
- Quick settings of 8 or 14 hours
- Complementary outputs simplify designs
- External reset input for system use
- Internal pullup resistors for switch inputs
- High current drive outputs - up to 25 mA
- Line frequency input for accurate timing

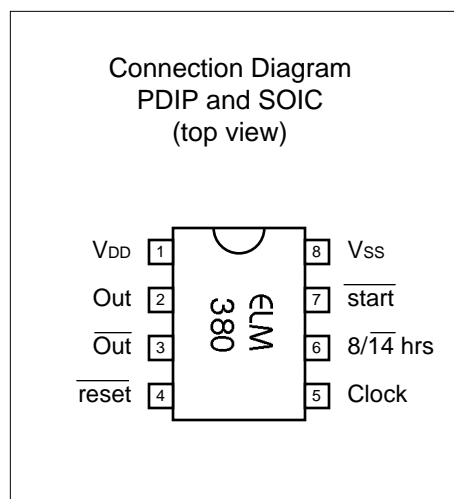

Block Diagram

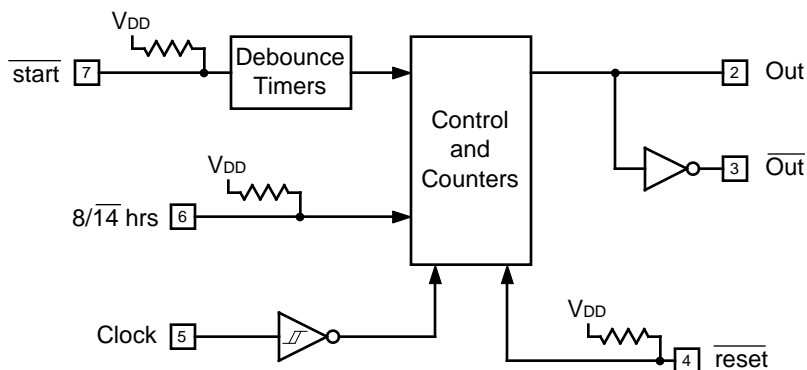



Pin Descriptions

VDD (pin 1)

This pin is the positive supply pin, and should always be the most positive point in the circuit. Internal circuitry connected to this pin is used to provide power on reset of the microprocessor, so an external reset signal is normally not required. Refer to the Electrical Characteristics section for further information.

Out (pin 2), and Out (pin 3)

These are the two complementary timer outputs. During a timing interval, pin 2 will go to a high logic level, and pin 3 will go low.

reset (pin 4)

This is an active low master reset input. If unused, it can be left open circuited (due to the internal resistor), or tied to VDD.

Clock (pin 5)

This is the master timekeeping input. Normally a 60Hz full-wave, positive going signal is applied to this Schmitt trigger input. Due to the internal clamp diodes, often the only other component required is a series connected resistor. Some circuit configurations may require a pulldown resistor to prevent the possibility of having a floating input.

8/14 hrs (pin 6)

This input pin selects either an eight hour (if high) or a 14 hour (if low) time interval when in the quick programming mode. The state of this pin is only determined at the end of eight hours.

start (pin 7)

A single momentary low on this pin is used to initiate a quick programming cycle of either 8 or 14 hours. Pressing this switch multiple times will program the timer for operation with the number of hours equal to the number of button presses. When there is more than two seconds with no switch activity, the circuit will assume that programming is complete, and issue a short (0.5sec) 'output off' to signal the user.

This input also provides an abort function which cancels any timing cycle that is in progress, if the input is held continuously low for more than three seconds. An internal debouncing circuit and a pullup resistor are provided on this pin to assist with the interface to mechanical switches.

Vss (pin 8)

Circuit common is connected to this pin. This is the most negative point in the circuit.

Ordering Information

These integrated circuits are available in either the 300 mil plastic DIP format, or in the 200 mil SOIC surface mount type of package. To order, add the appropriate suffix to the part number:

300 mil Plastic DIP..... ELM380P

200 mil SOIC..... ELM380SM

All rights reserved. Copyright ©1999 Elm Electronics.

Every effort is made to verify the accuracy of information provided in this document, but no representation or warranty can be given and no liability assumed by Elm Electronics with respect to the accuracy and/or use of any products or information described in this document. Elm Electronics will not be responsible for any patent infringements arising from the use of these products or information, and does not authorize or warrant the use of any Elm Electronics product in life support devices and/or systems. Elm Electronics reserves the right to make changes to the device(s) described in this document in order to improve reliability, function, or design.



Absolute Maximum Ratings

Storage Temperature..... -65°C to +150°C
 Ambient Temperature with
 Power Applied..... -40°C to +85°C
 Voltage on V_{DD} with respect to V_{SS}..... 0 to +7.5V
 Voltage on any other pin with
 respect to V_{SS}..... -0.6V to (V_{DD} + 0.6V)

Note:

Stresses beyond those listed here will likely damage the device. These values are given as a design guideline only. The ability to operate to these levels is neither inferred nor recommended.

Electrical Characteristics

All values are for operation at 25°C and a 5V supply, unless otherwise noted. For further information, refer to note 1 below.

Characteristic	Minimum	Typical	Maximum	Units	Conditions
Supply Voltage, V _{DD}	3.0	5.0	5.5	V	
V _{DD} rate of rise	0.05			V/ms	see note 2
Average Supply Current, I _{DD}		1.0	2.4	mA	V _{DD} = 5V, see note 3
Internal pullup resistances (see note 4)	300 20	500 30	600 50	K K	Pin 4 ($\overline{\text{reset}}$) Pin 6 (8/14) & pin 7 ($\overline{\text{start}}$)
Debounce period - $\overline{\text{start}}$ input		50		msec	with 120Hz (60Hz full-wave) clock
Input current	-0.5		+0.5	mA	clock input only, see note 5
Input low voltage	V _{SS}		0.15 V _{DD}	V	
Input high voltage	0.85 V _{DD}		V _{DD}	V	
Output low voltage			0.6	V	Current (sink) = 8.7mA
Output high voltage	V _{DD} - 0.7			V	Current (source) = 5.4mA

Notes:

1. This integrated circuit is produced with a Microchip Technology Inc.'s PIC12C5XX as the core embedded microcontroller. For further device specifications, and possibly clarification of those given, please refer to the appropriate Microchip documentation.
2. This spec must be met in order to ensure that a correct power on reset occurs. It is quite easily achieved using most common types of supplies, but may be violated if one uses a slowly varying supply voltage, as may be obtained through direct connection to solar cells, or some charge pump circuits.
3. Pullup resistor currents are not included in this figure.
4. The value of the internal pullup resistance is both supply and temperature dependent.
5. This specification represents current flowing through the protection diodes when applying large voltages to the clock input (pin 5) through a current limiting resistance. Currents quoted are the maximum continuous.

Example Application

Figure 1 shows the ELM380 used in a typical battery charger control circuit.

Power for this circuit is obtained from a 12V supply, as shown. Usually there will be a voltage of about this level available if the charger is to support 9V batteries. The 12V has been reduced to 5V through a 78L05 low power regulator. This is a relatively inexpensive and convenient way to obtain a stable voltage for a circuit such as this.

The required 120Hz for the clock input is obtained from the full-wave bridge as shown below. A series diode has been added to prevent back-feed from the filter capacitors (which would put a constant high level on the clock input), and a 47K resistor is connected in series with pin 5 to limit the current through the protection diodes when the AC bridge voltage exceeds the ELM380 supply levels.

After the peak of each sine wave, the series diode, and for a time, the bridge diodes, will not be conducting. This means that the clock input will be left floating, which is not advisable with CMOS circuits. To provide a

ground reference during these 'open circuit' periods, the 100K resistor was connected from this point to Vss.

The rest of the circuit is straightforward. Two switches are provided for control. Both the momentary action 'start' switch and the toggle type '8/14' switch have 300 series resistors for added ESD protection, and rely on the internal pullup resistors to provide a full logic swing when operated. The 300 resistors aren't strictly required, but are a nice addition to consider for added protection.

Only one of the outputs is used for this circuit. Its active high level is used to drive the NPN transistor into conduction and energize the relay coil. Depending on the circuit, a direct connection to the load might be used, but the use of a relay allows for general control of many different loads.

There are many other uses that this circuit could be put to. It could actually be used for almost any application that needs long time intervals... Lawn watering controls... Auto-off lighting systems...

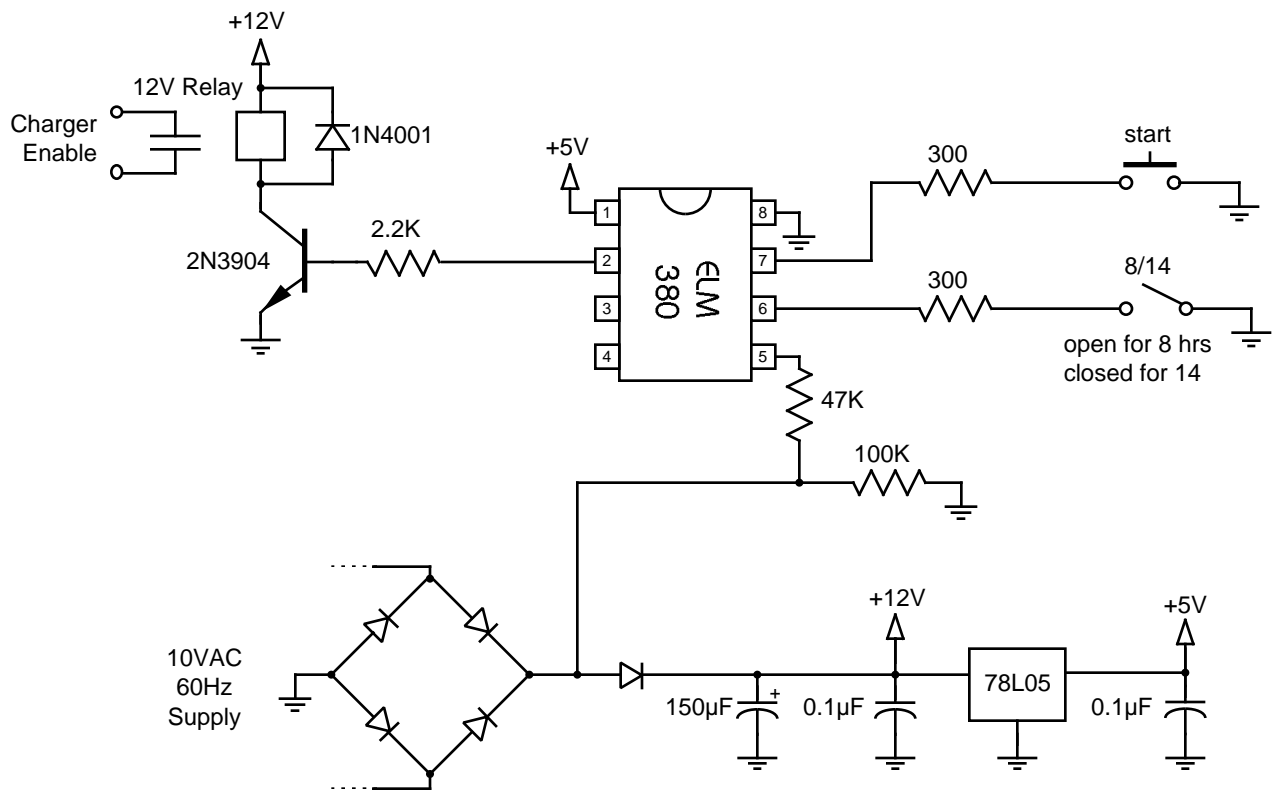

Figure 1. Typical Charger Control Circuit