

GENERAL DESCRIPTION

EM73963A is an advanced single chip CMOS 4-bit micro-controller. It contains 16K-byte ROM, 372-nibble RAM, 4-bit ALU, 13-level subroutine nesting, 22-stage time base, two 12-bit timer/counters for the kernel function. EM73963A also equipped with 5 interrupt sources, 3 I/O ports (including 1 input port and 2 bidirection ports), LCD display (40x8), built-in sound generator.

Its low power consumption and high speed feature are further strengthened with DUAL, SLOW, IDLE and STOP operation mode for optimized power saving.

FEATURES

- Operation voltage : 2.4V to 5.5V.
- Clock source : Dual clock system. Low-frequency oscillator is Crystal or RC oscillator (32KHz, connect a external resistor) by mask option and high-frequency oscillator is RC oscillator (connect a external resistor and a capacitor).
External clock and internal clock is available by mask option.
- Oscillation frequency : 480K, 1M, 2M and 4M Hz are both available for high frequency clock by mask option.
- Instruction set : 107 powerful instructions.
- Instruction cycle time : Up to 2 μ s for 4 MHz (high speed clock).
244 μ s for 32768 Hz (low speed clock).
- ROM capacity : 16K X 8 bits.
- RAM capacity : 372 X 4 bits.
- Input port : 1 port (P0.0-P0.3), IDLE/STOP releasing function is available by mask option.(each input pin has a pull-up and pull-down resistor available by mask option).
- Bidirection port : 2 ports (P4, P8). P4.0 and SOUND are available by mask option. IDLE/STOP release function for P8(0..3) is available by mask option.
- 12-bit timer/counter : Two 12-bit timer/counters are programmable for timer, event counter and pulse width measurement mode.
- Built-in time base counter : 22 stages.
- Subroutine nesting : Up to 13 levels.
- Interrupt : External 2 input interrupt sources.
Internal 2 Timer overflow interrupts.
1 Time base interrupt.
- LCD driver : 40 X 8 dots, 1/8 duty, 1/5 bias.
- Sound effect : Tone generator, random generator and volume control.
- Power saving function : SLOW, IDLE, STOP operation modes.
- Package type : Chip form 69 pins.

FUNCTION BLOCK DIAGRAM

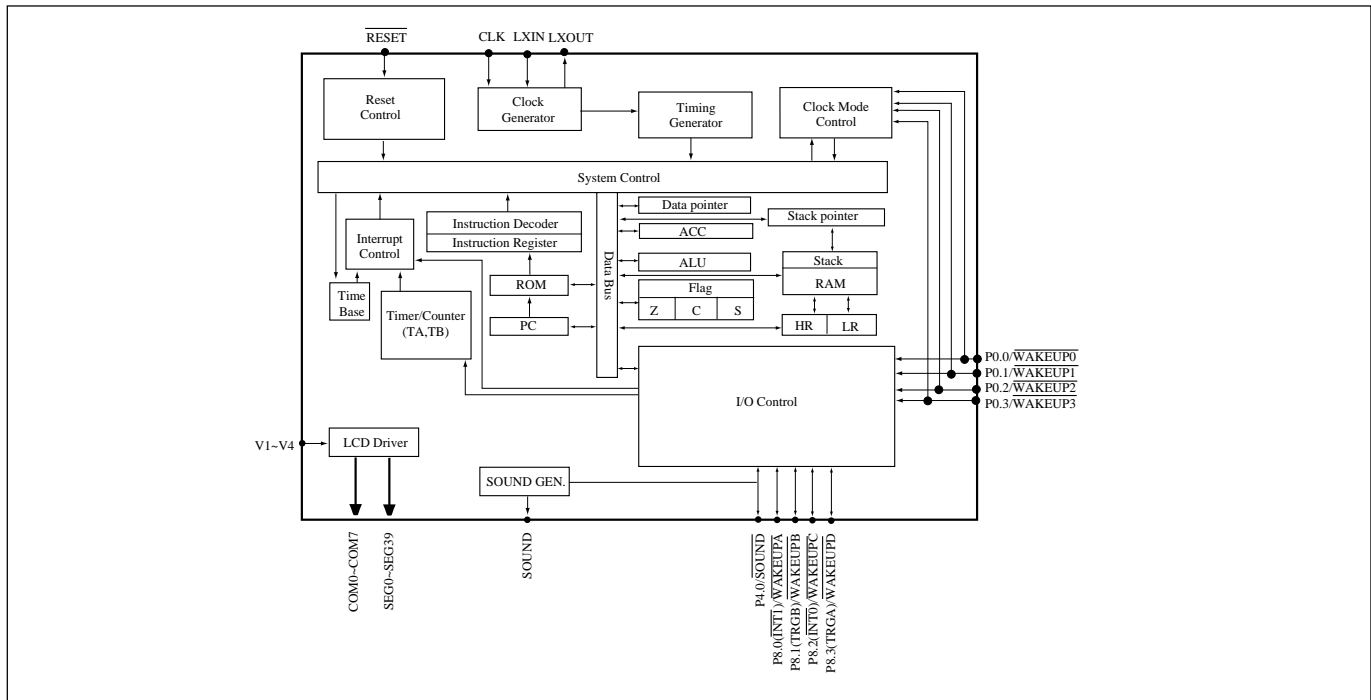

PIN DESCRIPTIONS

Symbol	Pin-type	Function
V _{DD}		Power supply (+)
V _{SS}		Power supply (-)
RESET	RESET-A	System reset input signal, low active mask option : none pull-up
CLK	OSC-C	RC or external clock source connecting pin for high speed clock source.
LXIN	OSC-B/OSC-F	Crystal/RC connecting pin for low speed clock source.
LXOUT	OSC-B/OSC-F	Crystal/RC connecting pin for low speed clock source.
P0(0..3)/WAKEUP0..3	INPUT-B	4-bit input port with IDLE/STOP releasing function mask option : wakeup enable, pull-up wakeup enable, none wakeup disable, pull-up wakeup disable, pull-down wakeup disable, none
P4.0/SOUND	I/O-O	1-bit bidirection I/O port or inverse sound effect output mask option : SOUND enable, push-pull, high current PMOS SOUND disable, open-drain SOUND disable, push-pull, high current PMOS SOUND disable, push-pull, low current PMOS
P8.0(INT1)/WAKEUPA P8.2(INT0)/WAKEUPC	I/O-L	2-bit bidirection I/O port with external interrupt sources input and IDLE/STOP releasing function mask option : wakeup enable, push-pull wakeup disable, push-pull wakeup disable, open-drain

Symbol	Pin-type	Function
P8.1(TRGB)/WAKEUPB P8.3(TRGA)/WAKEUPD	I/O-L	2-bit bidirection I/O port with time/counter A,B external input and IDLE /STOP releasing function mask option : wakeup enable, push-pull wakeup disable, push-pull wakeup disable, open-drain
SOUND		Built-in sound effect output
V1, V2, V3, V4		LCD bias voltage input
COM0~COM7		LCD common output pins
SEG0~SEG39		LCD segment output pins
TEST		Tie VSS as package type, no connecting as COB type

FUNCTION DESCRIPTIONS

PROGRAM ROM (16K X 8 bits)

16 K x 8 bits program ROM contains user's program and some fixed data.

The basic structure of the program ROM may be categorized into 5 partitions.

1. Address 0000h: Reset start address.
2. Address 0002h - 000Ch : 5 kinds of interrupt service routine entry addresses.
3. Address 000Eh-0086h : SCALL subroutine entry address, only available at 000Eh,0016h,001Eh,0026h, 002Eh, 0036h, 003Eh, 0046h, 004Eh, 0056h, 005Eh, 0066h, 006Eh, 0076h, 007Eh,0086h.
4. Address 0000h - 07FFh : LCALL subroutine entry address.
5. Address 0000h - 1FFFh : Except used as above function, the other region can be used as user's program and data region.

address Bank 0 :

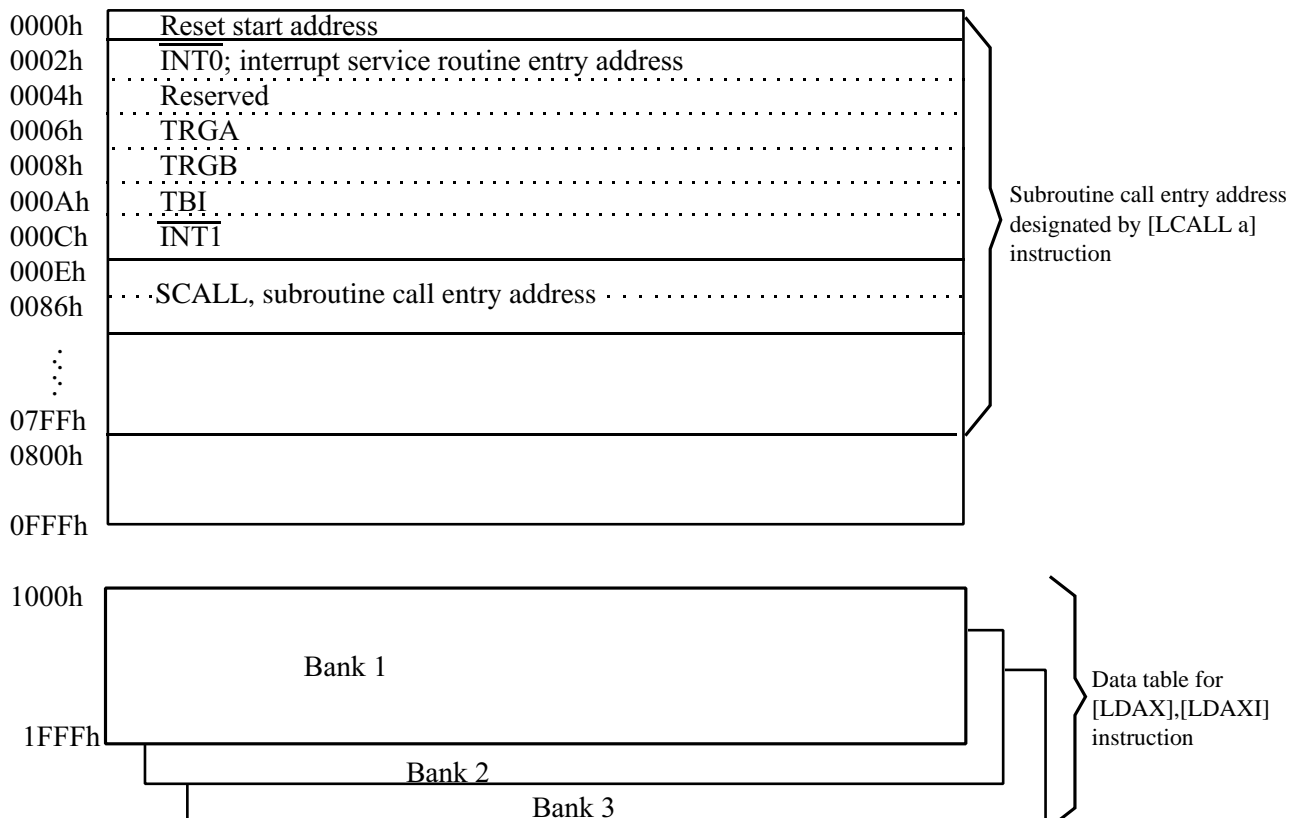

* This specification are subject to be changed without notice.

User's program and fixed data are stored in the program ROM. User's program is executed using the PC value to fetch an instruction code.

The 16Kx8 bits program ROM can be divided into 4 banks. There are 4Kx8 bits per bank.

The program ROM bank is selected by P3(1..0). The program counter is a 13-bit binary counter. The PC and P3 are initialized to "0" during reset.

When P3(1..0)=00B, the bank0 and bank1 of program ROM will be selected. P3(1..0)=01B, the bank0 and bank2 will be selected.

Address	P3=xx00B	P3=xx01B	P3=xx10B
0000h	Bank0	Bank0	Bank0
:			
0FFFh			
1000h	Bank1	Bank2	Bank3
:			
1FFFh			

PROGRAM EXAMPLE:

```

BANK 0
START:  :
        :
        :
        LDIA #00H           ; set program ROM to bank1
        OUTA P3
        B    XA1
        :
XA :    :
        :
        LDIA #01H           ; set program ROM to bank2
        OUTA P3
        B    XB1
        :
XB :    :
        :
        LDIA #02H           ; set program ROM to bank3
        OUTA P3
        B    XC1
        :
XC :    :
        :
        B    XD
XD :    :
        :
        :
-----
BANK 1
XA1 :   :
        :
        B    XA
        :
XA2 :   :

```



Fixed data can be read out by table-look-up instruction. Table-look-up instruction requires the Data point (DP) to indicate the ROM address in obtaining the ROM code data (Except bank 0) :

LDAX **Acc ← ROM[DP]_L**
LDAXI **Acc ← ROM[DP]_H,DP+1**

DP is a 12-bit data register that stores the program ROM address as pointer for the ROM code data. User has to initially load ROM address into DP with instructions "STADPL", and "STADPM, STADPH", then to obtain the lower nibble of ROM code data by instruction "LDAX" and higher nibble by instruction "LDAXI"

PROGRAM EXAMPLE: Read out the ROM code of address 1777h by table-look-up instruction.

```

LDIA #07h;
STADPL ; [DP]L ← 07h
STADPM ; [DP]M ← 07h
STADPH ; [DP]H ← 07h, Load DP=777h
:
OUT #00H , P3 ; Set in bank 1
LDL #00h;
LDH #03h;
LDAX ; ACC ← 6h
STAMI ; RAM[30] ← 6h
LDAXI ; ACC ← 5h
STAM ; RAM[31] ← 5h
;
ORG 1777h
DATA 56h;

```

DATA RAM (372-nibble)

A total 372 - nibble data RAM is available from address 000 to 17Fh
Data RAM includes the zero page region, stacks and data area.

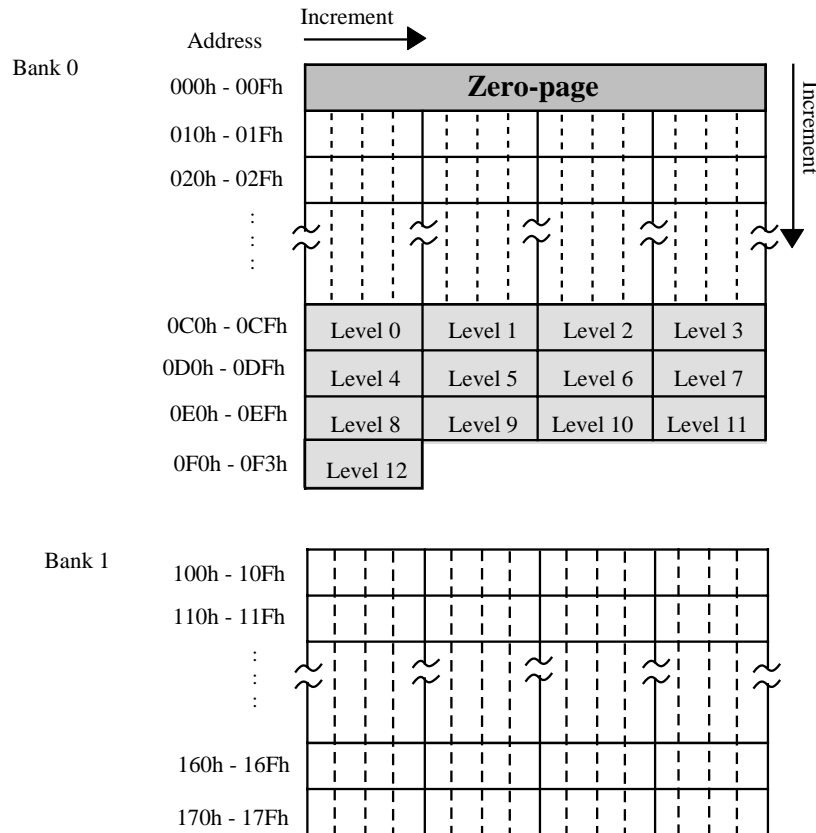

ZERO- PAGE:

From 000h to 00Fh is the zero-page location. It is used as the zero-page address mode pointer for the instruction of "STD #k,y; ADD #k,y; CLR y,b; CMP k,y".

PROGRAM EXAMPLE: To write immediate data "07h" to RAM [03] and to clear bit 2 of RAM [0Eh].
 STD #07h, 03h ; RAM[03] ← 07h
 CLR 0Eh,2 ; RAM[0Eh]₂ ← 0

STACK:

There are 13 - level (maximum) stack levels that user can use for subroutine (including interrupt and CALL). User can assign any level be the starting stack by providing the level number to stack pointer (SP). When an instruction (CALL or interrupt) is invoked, before enter the subroutine, the previous PC address is saved into the stack. Until returned from those subroutines, the PC value is restored by the data saved in stack.

DATA AREA:

Except the area used by user's application, the whole RAM can be used as data area for storing and loading general data.

ADDRESSING MODE

The 372 nibble data memory consists of two banks (bank 0 and bank 1). There are 244x4 bits (address 000h~0F3h) in bank 0 and 128x4 bits (address 100h~17Fh) in bank 1.

The bank is selected by P9.3. When P9.3 is cleared to "0", the bank 0 is selected, when P9.3 is set to "1", the bank 1 is selected.

The data Memory consists of three Address mode, namely -

(1) Indirect addressing mode:

The address in the bank is specified by the HL registers.

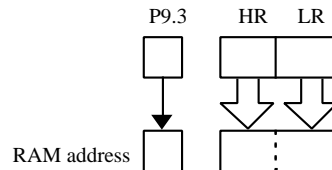

PROGRAM EXAMPLE: Load the data of RAM address "143h" to RAM address "023h".

```

SEP P9,3 ; P9.3← 1
LDL #3h ; LR← 3
LDH #4h ; HR← 4
LDAM ; Acc← RAM[134h]
CLP P9,3 ; P9.3← 0
LDL #2h ; LR← 2
LDH #3h ; HR← 3
STAM ; RAM[023h]← Acc
    
```

(2) Direct addressing mode:

The address in the bank is directly specified by 8 bits of the second byte in the instruction field.

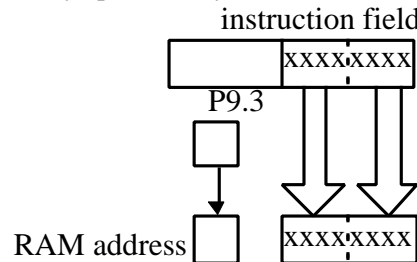

PROGRAM EXAMPLE: Load the data of RAM address "143h" to RAM address "023h".

```

SEP P9,3 ; P9.3← 1
LDA 43h ; Acc← RAM[143h]
CLP P9,3 ; P9.3← 0
STA 23h ; RAM[023h]← Acc
    
```

(3) Zero-page addressing mode:

The zero-page is in the bank 0 (address 000h~00Fh). The address is the lower 4 bits of the second byte in the instruction field.

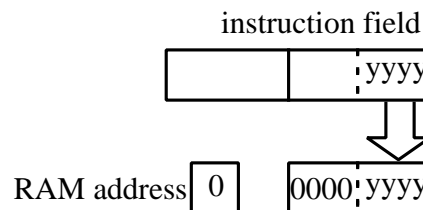

PROGRAM EXAMPLE: Write immediate "0Fh" to RAM address "005h".

```

STD #0Fh, 05h ; RAM[05h]← 0Fh
    
```

PROGRAM COUNTER (16K ROM)

Program counter (PC) is composed by a 13-bit counter, which indicates the next executed address for the program ROM instruction.

For BRANCH and CALL instructions, PC is changed by instruction indicating. PC only can indicate the address from 0000h-1FFFh. The bank number is decided by P3.

(1) Branch instruction:

SBR a

Object code: 00aa aaaa

Condition: SF=1; PC ← PC_{12-6.a} (branch condition satisfied)

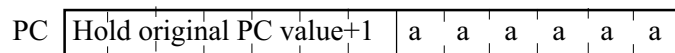

SF=0; PC← PC +1(branch condition not satisfied)

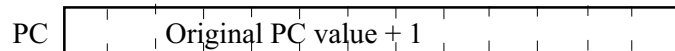

LBR a

Object code: 1100 aaaa aaaa aaaa

Condition: SF=1; PC ← PC_{12.a} (branch condition satisfied)

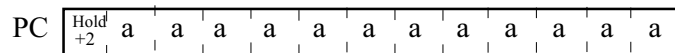

SF=0; PC← PC +2(branch condition not satisfied)

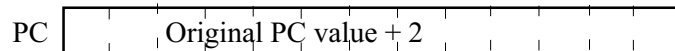

SLBR a

Object code: 0101 0101 1100 aaaa aaaa aaaa (a:1000h~1FFFh)

0101 0111 1100 aaaa aaaa aaaa (a:0000h~0FFFh)

Condition: SF=1; PC ← a (branch condition satisfied)

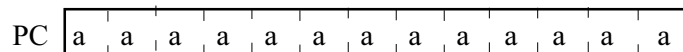

SF=0 ; PC ← PC + 3 (branch condition not satisfied)

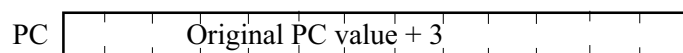

(2) Subroutine instruction:

SCALL a

Object code: 1110 nnnn

Condition : PC ← a ; a=8n+6 ; n=1..Fh ; a=86h, n=0

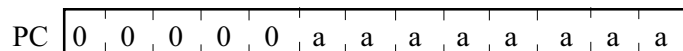

LCALL a

Object code: 0100 0aaa aaaa aaaa

Condition: PC ← a

PC

0	0	a	a	a	a	a	a	a	a	a	a	a
---	---	---	---	---	---	---	---	---	---	---	---	---

RET

Object code: 0100 1111

Condition: $PC \leftarrow STACK[SP]; SP + 1$

PC

The return address stored in stack												
------------------------------------	--	--	--	--	--	--	--	--	--	--	--	--

RTI

Object code: 0100 1101

Condition : FLAG. $PC \leftarrow STACK[SP]; EI \leftarrow 1; SP + 1$

PC

The return address stored in stack												
------------------------------------	--	--	--	--	--	--	--	--	--	--	--	--

(3) Interrupt acceptance operation:

When an interrupt is accepted, the original PC is pushed into stack and interrupt vector will be loaded into PC, The interrupt vectors are as follows :

$\overline{INT0}$ (External interrupt from P8.2)

PC

0	0	0	0	0	0	0	0	0	0	0	0	1	0
---	---	---	---	---	---	---	---	---	---	---	---	---	---

TRGA (Timer A overflow interrupt)

PC

0	0	0	0	0	0	0	0	0	0	1	1	0
---	---	---	---	---	---	---	---	---	---	---	---	---

TRGB (Time B overflow interrupt)

PC

0	0	0	0	0	0	0	0	0	0	1	0	0	0
---	---	---	---	---	---	---	---	---	---	---	---	---	---

TBI (Time base interrupt)

PC

0	0	0	0	0	0	0	0	0	0	1	0	1	0
---	---	---	---	---	---	---	---	---	---	---	---	---	---

$\overline{INT1}$ (External interrupt from P8.0)

PC

0	0	0	0	0	0	0	0	0	0	1	1	0	0
---	---	---	---	---	---	---	---	---	---	---	---	---	---

(4) Reset operation:

PC

0	0	0	0	0	0	0	0	0	0	0	0	0	0
---	---	---	---	---	---	---	---	---	---	---	---	---	---

(5) Other operations:

For 1-byte instruction execution: $PC + 1$

For 2-byte instruction execution: $PC + 2$

For 3-byte instruction execution: $PC + 3$

ACCUMULATOR

Accumulator is a 4-bit data register for temporary data storage. For the arithmetic, logic and comparative operation ..., ACC plays a role which holds the source data and result.

FLAGS

There are three kinds of flag, CF (Carry flag), ZF (Zero flag), and SF (Status flag), these three 1-bit flags are included by the arithmetic, logic and comparative operation.

All flags will be put into stack when an interrupt subroutine is served, and the flags will be restored after RTI instruction is executed.

(1) Carry Flag (CF)

The carry flag is affected by the following operations :

- a. Addition : CF as a carry out indicator, under addition operation, when a carry-out occurs, the CF is "1", likewise, if the operation has no carry-out, the CF is "0".
- b. Subtraction : CF as a borrow-in indicator, under subtraction operation, when a borrow occurs, the CF is "0", likewise, if there is no borrow-in, the CF is "1".
- c. Comparison: CF as a borrow-in indicator for Comparison operation as the same as subtraction operation.
- d. Rotation: CF shifts into the empty bit of accumulator for the rotation and holds the shift out data after rotation.
- e. CF test instruction : Under TFCFC instruction, the CF content is sent into SF then clear itself as "0". Under TTSFC instruction, the CF content is sent into SF then set itself as "1".

(2) Zero Flag (ZF)

ZF is affected by the result of ALU, if the ALU operation generates a "0" result, the ZF is "1", likewise, the ZF is "0".

(3) Status Flag (SF)

The SF is affected by instruction operation and system status.

- a. SF is initiated to "1" for reset condition.
- b. Branch instruction is decided by SF, when SF=1, branch condition is satisfied, likewise, when SF=0, branch condition is unsatisfied.

PROGRAM EXAMPLE:

Check following arithmetic operation for CF, ZF, SF

	CF	ZF	SF
LDIA #00h;	-	1	1
LDIA #03h;	-	0	1
ADDA #05h;	-	0	1
ADDA #0Dh;	-	0	0
ADDA #0Eh;	-	0	0

ALU

The arithmetic operation of 4 - bit data is performed in ALU unit . There are 2 flags that can be affected by the result of ALU operation, ZF and SF. The operation of ALU is affected by CF only.

ALU STRUCTURE

ALU supported user arithmetic operation functions, including Addition, Subtraction and Rotaion.

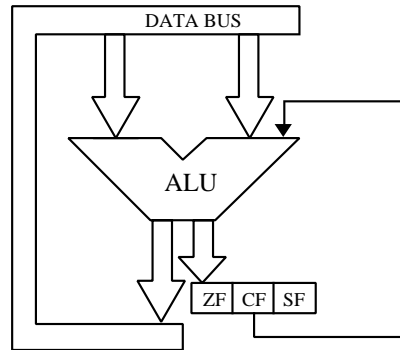

ALU FUNCTION

(1) Addition:

ALU supports addition function with instructions ADDAM, ADCAM, ADDM #k, ADD #k,y

The addition operation affects CF and ZF. Under addition operation, if the result is "0", ZF will be "1", otherwise, ZF will be "0", When the addition operation has a carry-out, CF will be "1", otherwise, CF will be "0".

EXAMPLE:

Operation	Carry	Zero
3+4=7	0	0
7+F=6	1	0
0+0=0	0	1
8+8=0	1	1

(2) Subtraction:

ALU supports subtraction function with instructions SUBM #k, SUBA #k, SBCAM, DECM.... The subtraction operation affects CF and ZF, Under subtraction operation, if the result is negative, CF will be "0", and a borrow out, otherwise, if the result is positive, CF will be "1". For ZF, if the result of subtraction operation is "0", the ZF is "1", otherwise, ZF is "1".

EXAMPLE:

Operation	Carry	Zero
8-4=4	1	0
7-F= -8(1000)	0	0
9-9=0	1	1

(3) Rotation:

There are two kinds of rotation operation, one is rotation left, the other is rotation right.
 RLCA instruction rotates Acc value to left, shift the CF value into the LSB bit of Acc and the shift out data will be hold in CF.

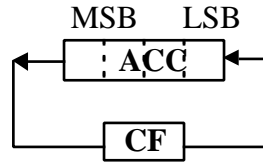

RRCA instruction operation rotates Acc value to right, shift the CF value into the MSB bit of Acc and the shift out data will be hold in CF.

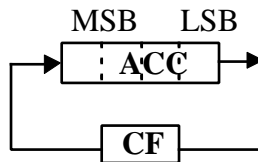

PROGRAM EXAMPLE: To rotate Acc clockwise(right) and shift a "1" into the MSB bit of Acc.

TTCFS; CF ← 1
 RRCA; rotate Acc right and shift CF=1 into MSB.

HL REGISTER

HL register are two 4-bit registers, they are used as a pair of pointer for the of RAM memory address. They are used as also 2 independent temporary 4-bit data registers. For certain instructions, L register can be a pointer to indicate the pin number (Port4 only).

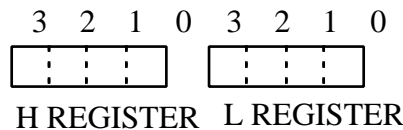
HL REGISTER STRUCTURE

HL REGISTER FUNCTION

(1) HL register is used as a temporary register for instructions : LDL #k, LDH #k, THA, THL, INCL, DECL, EXAL, EXAH.

PROGRAM EXAMPLE: Load immediate data "5h" into L register, "0Dh" into H register.
 LDL #05h;
 LDH #0Dh;

(2) HL register is used as a pointer for the address of RAM memory for instructions : LDAM, STAM, STAMI... .

PROGRAM EXAMPLE: Store immediate data "#0Ah" into RAM of address 35h.
 LDL #5h;
 LDH #3h;
 STDMI #0Ah; RAM[35] ← Ah

(3) L register is used as a pointer to indicate the bit of I/O port for instructions : SELP, CLPL, TFPL.

(When LR = 0 indicate P4.0)

PROGRAM EXAMPLE: To set bit 0 of Port4 to "1"

```
LDL #00h;
SEPL ; P4.0 ← 1
```

STACK POINTER (SP)

Stack pointer is a 4-bit register which stores the present stack level number. Before using stack, user must set the SP value first, CPU will not initiate the SP value after reset condition. When a new subroutine is received, the SP is decreased by one automatically, likewise, if returning from a subroutine, the SP is increased one. The data transfer between ACC and SP is done with instructions "LDASP" and "STASP".

DATA POINTER (DP)

Data pointer is a 12-bit register that stores the ROM address can indicating the ROM code data specified by user (refer to data ROM).

CLOCK AND TIMING GENERATOR

The clock generator is supported by a dual clock system. The high-frequency oscillator is source from RC oscillator, the working frequency range is 480 KHz to 4 MHz defined by the mask option. The low-frequency oscillator may be sourced from crystal or RC oscillator as defined by mask option, the working frequency is 32 KHz.

CLOCK GENERATOR STRUCTURE

There are two clock generator for system clock control unit, P14 is the status register that hold the CPU status. P16, P19 and P22 are the command register for system clock mode control

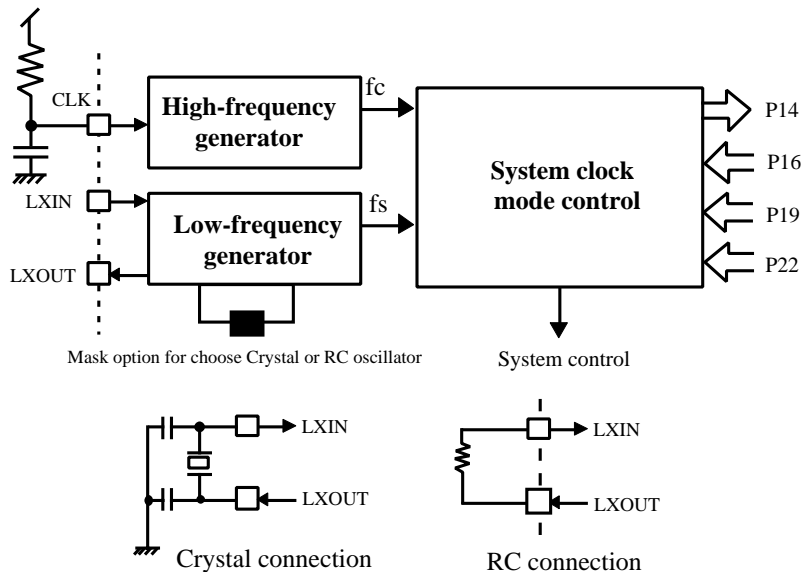

SYSTEM CLOCK MODE CONTROL

The system clock mode controller can start or stop the high-frequency and low-frequency clock oscillator and switch between the basic clocks. EM73963A has four operation modes (DUAL, SLOW, IDLE and STOP operation modes).

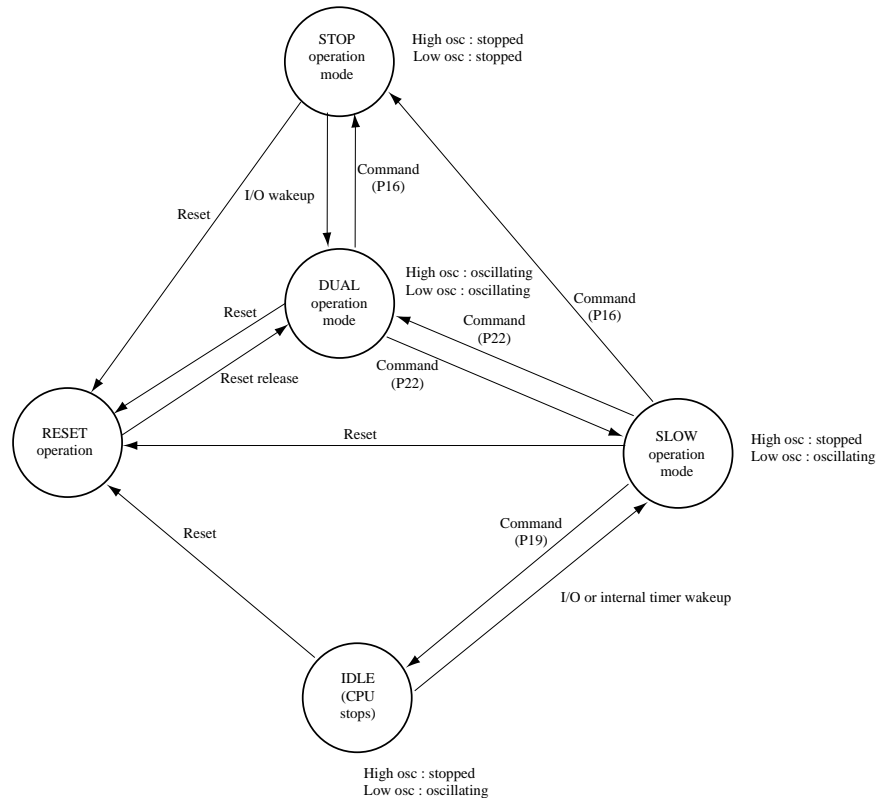

Operation Mode	Oscillator	System Clock	Available function	One instruction cycle
DUAL	High, Low frequency	High frequency clock	LCD, sound generator	8 / fc
SLOW	Low frequency	Low frequency clock	LCD	8 / fs
IDLE	Low frequency	CPU stops	LCD	-
STOP	None	CPU stops	All disable	-

DUAL OPERATION MODE

The 4-bit μ c is in the DUAL operation mode when the CPU is reseted. This mode is dual clock system (high-frequency and low-frequency clocks oscillating). It can be changed to SLOW or STOP operation mode with the command register (P22 or P16).

LCD display and sound generator are available for the DUAL operation mode.

SLOW OPERATION MODE

The SLOW operation mode is single clock system (low-frequency clock oscillating). It can be changed to the DUAL operation mode with the command register (P22), STOP operation mode with P16 and IDLE operation mode with P19.

LCD display is available for the SLOW operation mode.

P22 3 2 1 0 Initial value : 0000

*	SOM
---	-----

SOM	Select operation mode
0 0 0	DUAL operation mode
1 * *	SLOW operation mode

P14 3 2 1 0 Initial value : *000

*	WKS	LFS	CPUS
---	-----	-----	------

LFS	Low-frequency status	CPUS	CPU status
0	LXIN source is not stable	0	DUAL operation mode
1	LXIN source is stable	1	SLOW operation mode

WKS	Wakeup status
0	Wakeup not by internal timer
1	Wakeup by internal timer

Port14 is the status register for CPU. P14.0 (CPU status) and P14.1 (Low-frequency status) are read-only bits. P14.2 (wakeup status) will be set as '1' when CPU is waked by internal timer. P14.2 will be cleared as '0' when user out data to P14.

IDLE OPERATION MODE

The IDLE operation mode suspends all CPU functions except the low-frequency clock oscillation and the LCD driver. It keeps the internal status with low power consumption without stopping the slow clock oscillation and LCD display.

LCD display is available for the IDLE operation mode. Sound generator is disabled in this mode. The IDLE operation mode will be wakeup and return to the SLOW operation mode by the internal timing generator or I/O pins (P0(0..3)/WAKEUP 0..3 or P8(0..3)/WAKEUPA..D).

P19 3 2 1 0 Initial value : 0000

*	IDME	SIDR
---	------	------

IDME	Enable IDLE mode
1	Enable IDLE mode
0	no function

SIDR	Select IDLE releasing condition		
0 0	P0(0..3), P8(0..3) pin input		
0 1	P0(0..3), P8(0..3) pin input and 1 sec signal		
1 0	P0(0..3), P8(0..3) pin input and 0.5 sec signal		
1 1	P0(0..3), P8(0..3) pin input and 15.625 ms signal		

STOP OPERATION MODE

The STOP operation mode suspends system operation and holds the internal status immediately before the suspension with low power consumption. This mode will be released by reset or I/O pins (P0(0..3)/WAKEUP 0..3 or P8(0..3)/WAKEUP A..D).

LCD display and sound generator are disabled in the STOP operation mode.

P16 3 2 1 0 Initial value : 0000

*	SPME	SWWT
---	------	------

SPME	Enable STOP mode
1	Enable STOP mode
0	no function

SWWT	Set wake-up warm-up time
0 0	$2^{18}/\text{CLK}$
0 1	$2^{14}/\text{CLK}$
1 0	$2^{16}/\text{CLK}$
1 1	no function

TIME BASE INTERRUPT (TBI)

The time base can be used to generate a single fixed frequency interrupt. Eight types of frequencies can be selected with the "P25" setting.

P25 3 2 1 0
 initial value : 0000

P25	DUAL operation mode	SLOW operation mode
0 0 x x	Interrupt disable	Interrupt disable
0 1 0 0	Interrupt frequency LXIN / 2^3 Hz	Reserved
0 1 0 1	Interrupt frequency LXIN / 2^4 Hz	Reserved
0 1 1 0	Interrupt frequency LXIN / 2^5 Hz	Reserved
0 1 1 1	Interrupt frequency LXIN / 2^{14} Hz	Interrupt frequency LXIN / 2^{14} Hz
1 1 0 0	Interrupt frequency LXIN / 2^1 Hz	Reserved
1 1 0 1	Interrupt frequency LXIN / 2^6 Hz	Interrupt frequency LXIN / 2^6 Hz
1 1 1 0	Interrupt frequency LXIN / 2^8 Hz	Interrupt frequency LXIN / 2^8 Hz
1 1 1 1	Interrupt frequency LXIN / 2^{10} Hz	Interrupt frequency LXIN / 2^{10} Hz
1 0 x x	Reserved	Reserved

TIMER / COUNTER (TIMER A, TIMER B)

Timer/counters support three special functions:

1. Even counter
2. Timer.
3. Pulse-width measurement.

These three functions can be executed by 2 timer/counter independently.

With timerA, the counter data is saved in timer register TAH, TAM, TAL. User can set counter initial value and read the counter value by instruction "LDATAH(M,L)" and "STATAH(M,L)". With timer B register is TBH, TBM, TBL and the W/R instruction "LDATBH (M,L)" and "STATBH (M,L)".

The basic structure of timer/counter is composed by two identical counter module, these two modules can be set initial timer or counter value to the timer registers, P28 and P29 are the command registers for timer A and timer B, user can choose different operation modes and internal clock rates by setting these two registers. When timer/counter overflows, it will generate a TRGA(B) interrupt request to interrupt control unit.

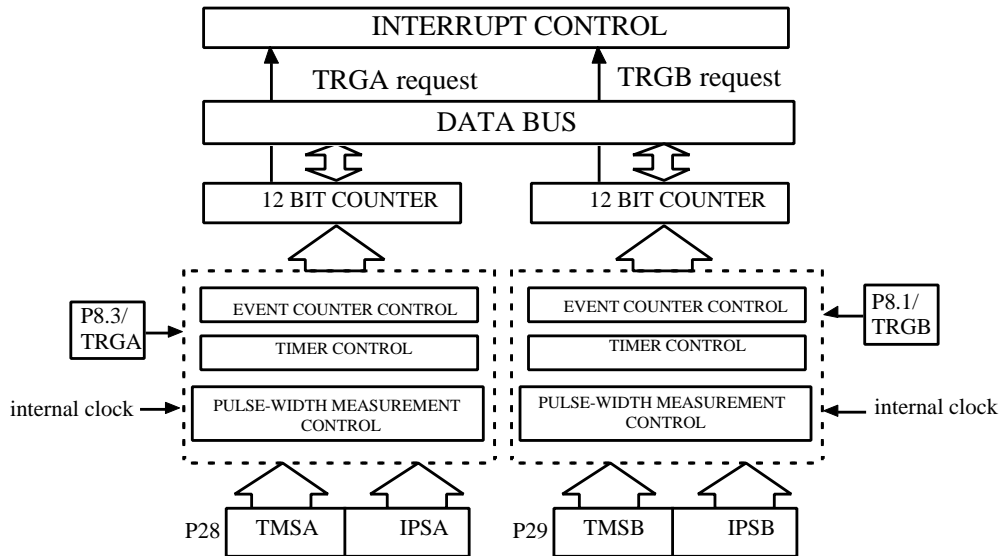

TIMER/COUNTER CONTROL

P8.1/TRGB, P8.3/TRGA are the external timer inputs for timerB and timerA, they are used in event counter and pulse-width measurement mode.

Timer/counter command port: P28 is the command port for timer/counterA and P29 is for the timer/counterB.

Port 28	<table border="1" style="border-collapse: collapse; width: 100%;"> <tr> <td style="width: 25%; text-align: center;">3</td> <td style="width: 25%; text-align: center;">2</td> <td style="width: 25%; text-align: center;">1</td> <td style="width: 25%; text-align: center;">0</td> </tr> <tr> <td style="text-align: center;">TMSA</td> <td style="text-align: center;">IPSA</td> <td colspan="2"></td> </tr> </table> <p style="text-align: center;">Initial state: 0000</p>	3	2	1	0	TMSA	IPSA			<table border="1" style="border-collapse: collapse; width: 100%;"> <thead> <tr> <th colspan="2" style="text-align: center;">TIMER/COUNTER MODE SELECTION</th> </tr> <tr> <th style="width: 20%;">TMSA (B)</th> <th style="width: 80%;">Function description</th> </tr> </thead> <tbody> <tr> <td style="text-align: center;">0 0</td> <td>Stop</td> </tr> <tr> <td style="text-align: center;">0 1</td> <td>Event counter mode</td> </tr> <tr> <td style="text-align: center;">1 0</td> <td>Timer mode</td> </tr> <tr> <td style="text-align: center;">1 1</td> <td>Pulse width measurement mode</td> </tr> </tbody> </table>	TIMER/COUNTER MODE SELECTION		TMSA (B)	Function description	0 0	Stop	0 1	Event counter mode	1 0	Timer mode	1 1	Pulse width measurement mode
3	2	1	0																			
TMSA	IPSA																					
TIMER/COUNTER MODE SELECTION																						
TMSA (B)	Function description																					
0 0	Stop																					
0 1	Event counter mode																					
1 0	Timer mode																					
1 1	Pulse width measurement mode																					
Port 29	<table border="1" style="border-collapse: collapse; width: 100%;"> <tr> <td style="width: 25%; text-align: center;">3</td> <td style="width: 25%; text-align: center;">2</td> <td style="width: 25%; text-align: center;">1</td> <td style="width: 25%; text-align: center;">0</td> </tr> <tr> <td style="text-align: center;">TMSB</td> <td style="text-align: center;">IPSB</td> <td colspan="2"></td> </tr> </table> <p style="text-align: center;">Initial state: 0000</p>	3	2	1	0	TMSB	IPSB															
3	2	1	0																			
TMSB	IPSB																					

INTERNAL PULSE-RATE SELECTION		
IPSA(B)	DUAL mode	SLOW mode
0 0	$LXIN/2^3$ Hz	Reserved
0 1	$LXIN/2^7$ Hz	$LXIN/2^7$ Hz
1 0	$LXIN/2^{11}$ Hz	$LXIN/2^{11}$ Hz
1 1	$LXIN/2^{15}$ Hz	$LXIN/2^{15}$ Hz

TIMER/COUNTER FUNCTION

Timer/counterA, B are can be programmable for timer, event counter and pulse width measurement mode. Each timer/counter can execute any of these functions independently.

EVENT COUNTER MODE

Under event counter mode, the timer/counter is increased by one at any rising edge of P8.1/TRGB for timerB (P8.3/TRGA for timer A). When timerB (timerA) counts overflow, it will provide an interrupt request TRGB (TRGA) to interrupt control unit.

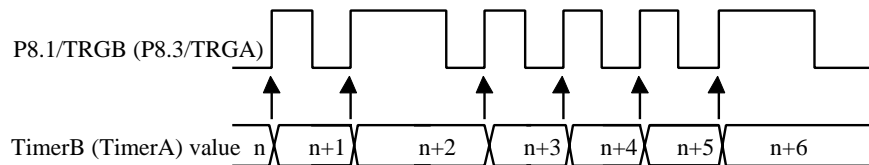

PROGRAM EXAMPLE: Enable timerA with P28

```
LDIA #0100b;
OUTA P28; Enable timerA with event counter mode
```

TIMER MODE

Under timer mode, the timer/counter is increased by one at any rising edge of internal pulse. User can choose up to 4 types of internal pulse rate by setting IPSB for timerB (IPSA for timerA). When timer/counter counts overflow, an interrupt request will be sent to interrupt control unit.

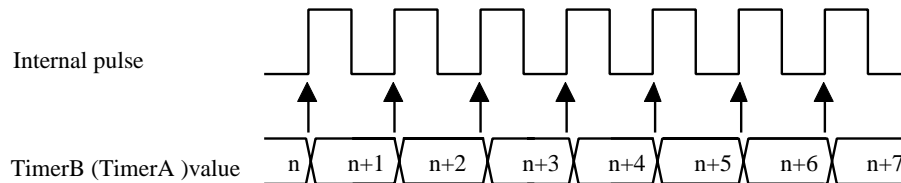

PROGRAM EXAMPLE: To generate TRGA interrupt request after 60 ms with system clock LXIN=32KHz

```
LDIA #0100B;
EXAE; enable mask 2
EICIL 110111b; interrupt latch ←0, enable EI
LDIA #0Ah;
STATAL;
LDIA #00h;
STATAM;
LDIA #0Fh;
STATAH;
LDIA #1000B;
OUTA P28; enable timerA with internal pulse rate: LXIN/23 Hz
```

NOTE: The preset value of timer/counter register is calculated as following procedure.
 Internal pulse rate: $LXIN/2^3$; $LXIN = 32KHz$
 The time of timer counter count one = $2^3 / LXIN = 8/32768=0.244ms$
 The number of internal pulse to get timer overflow = $60 ms / 0.244ms = 245.901 = 0F6h$
 The preset value of timer/counter register = $1000h - 0F6h = F0Ah$

PULSE WIDTH MEASUREMENT MODE

Under the pulse width measurement mode, the counter is increased at the rising edge of internal pulse during external timer/counter input (P8.1/TRGB, P8.3/TRGA) in high level, interrupt request is generated as soon as timer/counter count overflow.

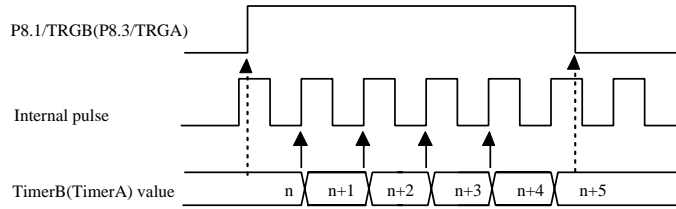

PROGRAM EXAMPLE: Enable timerA by pulse width measurement mode.

LDIA #1100b;

OUTA P28; Enable timerA with pulse width measurement mode.

INTERRUPT FUNCTION

Five interrupt sources are available, 2 from external interrupt sources and 3 from internal interrupt sources. Multiple interrupts are admitted according to their priority.

Type	Interrupt source	Priority	Interrupt Latch	Interrupt Enable condition	Program ROM entry address
External	External interrupt($\overline{INT0}$)	1	IL5	EI=1	002h
Internal	Reserved	2	IL4	EI=1, MASK3=1	004h
Internal	TimerA overflow interrupt (TRGA)	3	IL3	EI=1, MASK2=1	006h
Internal	TimerB overflow interrupt (TRGB)	4	IL2	EI=1, MASK1=1	008h
Internal	Time base interrupt(TBI)	5	IL1		00Ah
External	External interrupt($\overline{INT1}$)	6	IL0	EI=1, MASK0=1	00Ch

INTERRUPT STRUCTURE

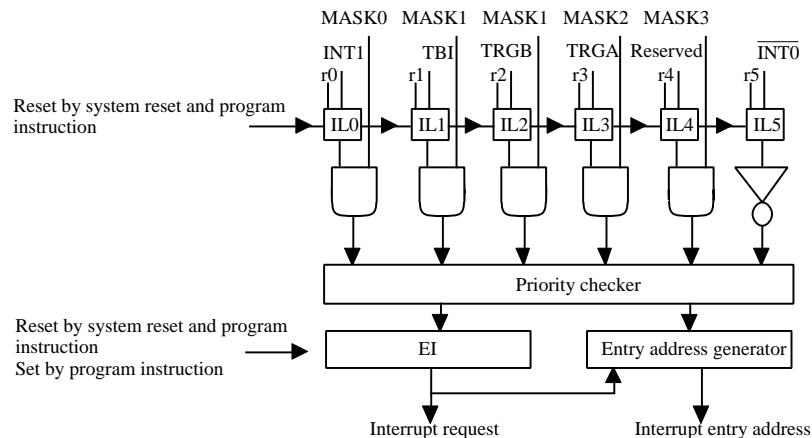

Interrupt controller:

IL0-IL5 : Interrupt latch. Hold all interrupt requests from all interrupt sources. IL's can not be set by program, but can be reset by program or system reset, so IL can only decide which interrupt source can be accepted.

MASK0-MASK3 : Except $\overline{INT0}$, MASK register may permit or inhibit all interrupt sources.

EI : Enable interrupt Flip-Flop can permit or inhibit all interrupt sources, when interrupt occurs, EI is auto cleared to "0" , after RTI instruction is executed, EI is auto set to "1" again .

Priority checker: Check interrupt priority when multiple interrupts occur.

INTERRUPT FUNCTION

The procedure of interrupt operation:

1. Push PC and all flags to stack.
2. Set interrupt entry address into PC.
3. Set SF= 1.
4. Clear EI to inhibit other interrupts occur.
5. Clear the IL with which interrupt source has already been accepted.
6. Excute interrupt subroutine from the interrupt entry address.
7. CPU accept RTI, restore PC and flags from stack . Set EI to accept other interrupt requests.

PROGRAM EXAMPLE: To enable interrupt of "INT0, TRGA"

```
LDIA #1100B;
EXAE; set mask register "1100B"
EICIL 010111B ; enable interrupt F.F and clear IL3 and IL5.
```

LCD DRIVER

It can directly drive the liquid crystal display (LCD) and has 40 segments , 8 commons output pins. There are total 40x8 dots can be display. The V1~V4 are the LCD bias voltage input pins.

(1) LCD driver control command register:

Port27 3 2 1 0 Initial value: 0000

LDC	*	*
LCD DISPLAY CONTROL		
LDC	Function description	
0 0	LCD display disable	
0 1	Blanking	
1 0	no function	
1 1	LCD display enable	

* : Don't care .

P27 is the LDC driver control command register . The initial value is 0000 .

When LDC (bit2 and bit3 of P27) is set to "00", the LCD display is disabled .

When LDC is set to "01", the LCD is blanking, the COM pins are inactive and the SEG pins output the display data continuously .

When LDC is set to "11", the LCD display is enabled.

(2) LCD display data area:

The LCD display data is stored in the display data area of the data memory (RAM) . The LCD display data area is as illustrated below:

The display data from the display data area are automatically read out and send to the LCD driver directly by the hardware. Therefore, the display patterns can be changed only by overwriting the contents of the display data area through software.

The display memory area that is not used to store the LCD display data could be used as the ordinary data memory.

LCD display data area :

Bank1

P9.3=1

	0	1	2	3	4	5	6	7	8	9	A	B	C	D	E	F
100-10Fh	COM0															
110-11Fh	COM1															
120-12Fh	COM2															
130-13Fh	COM3															
140-14Fh	COM4															
150-15Fh	COM5															
160-16Fh	COM6															
170-17Fh	COM7															

SEG0
SEG1
SEG2
SEG3
SEG4
SEG5
SEG6
SEG7
SEG8
SEG9
SEG10
SEG11
SEG12
SEG13
SEG14
SEG15
SEG16
SEG17
SEG18
SEG19
SEG20
SEG21
SEG22
SEG23
SEG24
SEG25
SEG26
SEG27
SEG28
SEG29
SEG30
SEG31
SEG32
SEG33
SEG34
SEG35
SEG36
SEG37
SEG38
SEG39

P26 is the start address register of LCD common pin.

Port26 3 2 1 0 Initial value: *000

*	3	2	1	0
CSA				

CSA	Common start address register							
	RAM							
	100-109h	110-119h	120-129h	130-139h	140-149h	150-159h	160-169h	170-179h
X000	COM0	COM1	COM2	COM3	COM4	COM5	COM6	COM7
X001	COM7	COM0	COM1	COM2	COM3	COM4	COM5	COM6
X010	COM6	COM7	COM0	COM1	COM2	COM3	COM4	COM5
X011	COM5	COM6	COM7	COM0	COM1	COM2	COM3	COM4
X100	COM4	COM5	COM6	COM7	COM0	COM1	COM2	COM3
X101	COM3	COM4	COM5	COM6	COM7	COM0	COM1	COM2
X110	COM2	COM3	COM4	COM5	COM6	COM7	COM0	COM1
X111	COM1	COM2	COM3	COM4	COM5	COM6	COM7	COM0

PROGRAM EXAMPLE:

```

LDIA    #0000B
OUTA    P26
LDIA    #1100B ; LCD display enable
OUTA    P27
LDIA    #1010B ; store 1010B to RAM[101h]
SEP     P9,3
STA     01H
    
```

(3) LCD waveform : (1/5 bias)

Although there are two LCD waveform types, but for the reason of the number of voltage transition point in type A is greater than type B, so type B gets a better display performance.

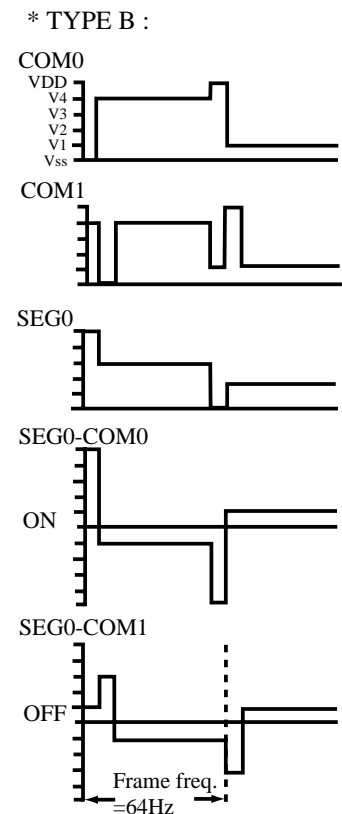
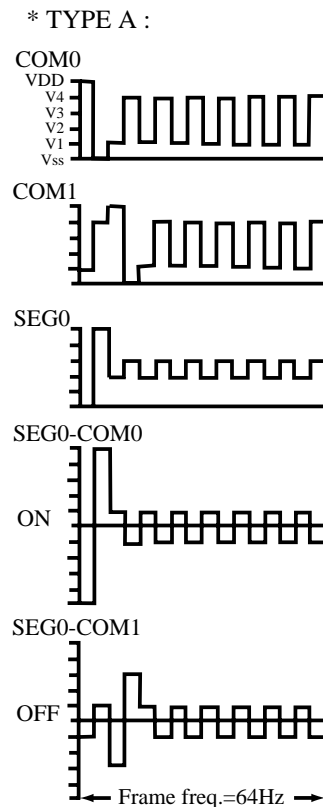
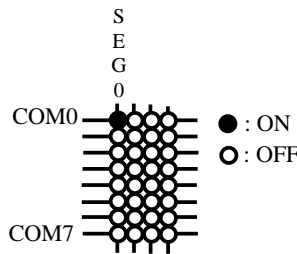

(4) LCD bias resistor :

There are high and low resistance choices for LCD bias resistor. To choose low bias resistor will take more power but get a better display performance.

(5) LCD bias supply :

The LCD bias voltage can be supplied by bias resistor. When user chooses a large bias resistor or uses a large LCD panel, to connect 4 capacitors to V1~V4 can get a better display performance. Otherwise, you can open V1~V4 and ignore these 4 capacitors.

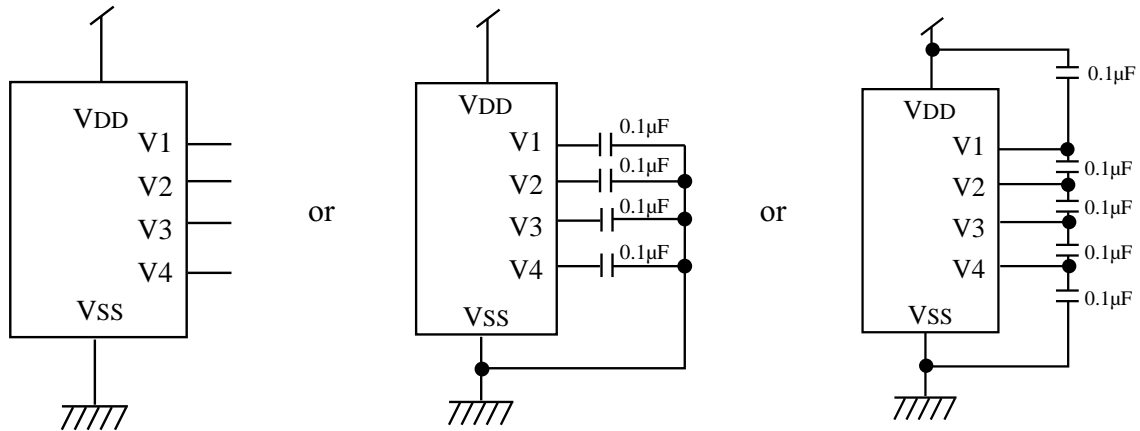

SOUND EFFECT

EM73963A has a built-in sound effect generator. It includes the tone generator, random generator and volume control. The tone generator is a binary down counter and random generator is a 9-bit linear feedback shift register. The sound generator is available for the DUAL mode. When the CPU is reseted or in the IDLE or STOP operation mode, the sound generator is disable and the P4.0/SOUND is in high state and SOUND is in low state.

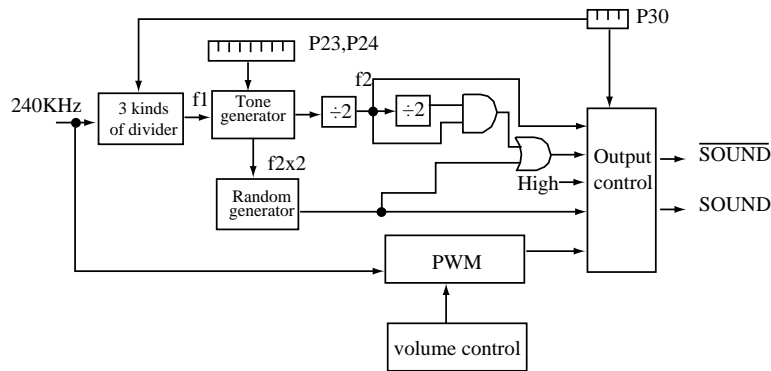

Sound generator command register

Three basic frequencies for sound generator can be selected by P30. The output of sound effect generator can be tone, random tone or both combination.

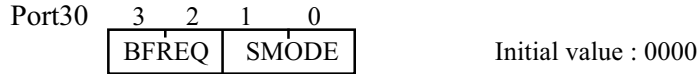

BFREQ	Basic frequency (f1) select
0 0	240 KHz
0 1	120 KHz
1 0	60 KHz
1 1	don't care

SMODE	Sound generator mode
0 0	Disable
0 1	Tone output
1 0	Random output
1 1	Tone+random output

Tone frequency register

The 8-bit tone frequency register (TF) is P24 and P23. The tone frequency will be changed when user output the different data to P24 and P23.

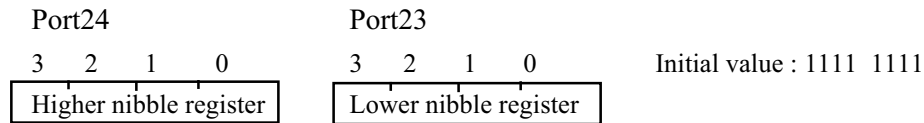

- ** $f1=240K/2^x$, $f2=f1/(TF+1)/2$, $TF=1\sim255$, $TF=0$
- ** Example : BFREQ=10, TF=00110001B.
- ⇒ $f1=60K$ Hz, $f2=60K$ Hz/50/2=600 Hz

Random generator

$f(x)=x^9+x^4+1$

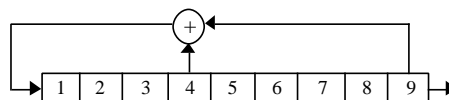

Volume control register

The are 8 volume levels for sound generator. P17 is the volume control register.



VCR	ts/tp
1 1 1	8/8
1 1 0	7/8
1 0 1	6/8
1 0 0	5/8
0 1 1	4/8
0 1 0	3/8
0 0 1	2/8
0 0 0	1/8

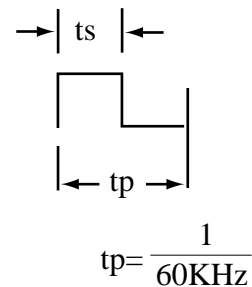

PROGRAM EXAMPLE:

```

LDIA    #1001B ; basic frequency : 60 KHz tone output
OUTA    P30
LDIA    #0011B ; volume control
OUTA    P17
LDIA    #0011B ; 600 Hz tone output
OUTA    P24
LDIA    #0001B
OUTA    P23
    
```

RESETTING FUNCTION

When CPU in normal working condition and $\overline{\text{RESET}}$ pin is held in low level for three instruction cycles at least, then CPU begins to initialize the whole internal states, when $\overline{\text{RESET}}$ pin changes to high level, CPU begins to work in normal condition.

The CPU internal state during reset condition is as following table :

Hardware condition in RESET state	Initial value
Program counter	0000h
Status flag	01h
Interrupt enable flip-flop (EI)	00h
MASK0 ,1, 2, 3	00h
Interrupt latch (IL)	00h
P3, 9, 14, 16, 17, 19, 22, 25, 26, 27, 28, 29, 30	00h
P4, 8, 17, 23, 24	0Fh
CLK, LXIN	Start oscillation

The $\overline{\text{RESET}}$ pin is a hysteresis input pin and it has a pull-up resistor available by mask option. The simplest RESET circuit is connect $\overline{\text{RESET}}$ pin with a capacitor to V_{SS} and a diode to V_{DD} .

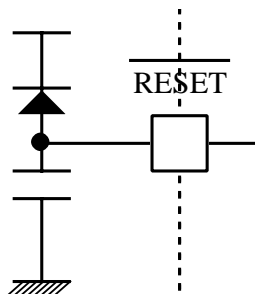

EM73963A I/O PORT DESCRIPTION :

Port		Input function		Output function	Note
0	E	Input port , wakeup function			
1		--		--	
2		--		--	
3		--	I	P3(0..2) : ROM bank selection	
4	E	Input port	E	Output port, P4.0/SOUND	
5		--		--	
6		--		--	
7		--		--	
8	E	Input port, wakeup function, external interrupt input	E	Output port	
9		--	I	P9.3 : RAM bank selection	
10		--		--	
11		--		--	
12		--		--	
13		--		--	
14	I	CPU status register		--	
15		--		--	
16			I	STOP mode control register	
17			I	Sound effect volume control register	
18				--	
19			I	IDLE mode control register	
20				--	
21				--	
22			I	DUAL/SLOW mode control register	
23			I	Sound effect frequency register	low nibble
24			I	Sound effect frequency register	high nibble
25			I	Timebase control register	
26			I	LCD common start address register	
27			I	LCD control register	
28			I	Timer/counter A control register	
29			I	Timer/counter B control register	
30			I	Sound effect command register	
31				--	

ABSOLUTE MAXIMUM RATINGS

Items	Sym.	Ratings	Conditions
Supply Voltage	V_{DD}	-0.5V to 6V	
Input Voltage	V_{IN}	-0.5V to $V_{DD}+0.5V$	
Output Voltage	V_O	-0.5V to $V_{DD}+0.5V$	
Power Dissipation	P_D	300mW	$T_{OPR}=50^{\circ}C$
Operating Temperature	T_{OPR}	0°C to 50°C	
Storage Temperature	T_{STG}	-55°C to 125°C	

RECOMMENDED OPERATING CONDITIONS

Items	Sym.	Ratings	Condition
Supply Voltage	V_{DD}	2.4V to 5.5V	
Input Voltage	V_{IH}	$0.90 \times V_{DD}$ to V_{DD}	
	V_{IL}	0V to $0.10 \times V_{DD}$	
Operating Frequency	F_C	480K to 4MHz	CLK (RC osc)
	F_s	32KHz	LXIN,LXOUT (crystal/RC osc)

DC ELECTRICAL CHARACTERISTICS ($V_{DD}=3 \pm 0.3V$, $V_{SS}=0V$, $T_{OPR}=25^{\circ}C$)

Parameters	Sym.	Min.	Typ.	Max.	Unit	Conditions
Supply current	I_{DD}	-	0.9	2	mA	$V_{DD}=3.3V$, no load, NORMAL mode, $F_s=32KHz$ ($R=750k\Omega$), $F_c=4MHz$ (RC osc : $R=5.6K\Omega$, $C=20pF$)
		-	12	25	μA	$V_{DD}=3.3V$, no load, SLOW mode, $F_s=32KHz$ LCD on
		-	4	10	μA	$V_{DD}=3.3V$, IDLE mode, LCD off
		-	0.1	1	μA	$V_{DD}=3.3V$, STOP mode
Hysteresis voltage	V_{HYS+}	$0.50V_{DD}$	-	$0.75V_{DD}$	V	RESET, P0, P8
	V_{HYS-}	$0.20V_{DD}$	-	$0.40V_{DD}$	V	
Input current	I_{IH}	-	-	± 1	μA	P0, RESET, $V_{DD}=3.3V$, $V_{IH}=3.3/0V$
		-	-	± 1	μA	Open-drain, $V_{DD}=3.3V$, $V_{IH}=3.3/0V$
	I_{IL}	-	-250	-500	μA	Push-pull, $V_{DD}=3.3V$, $V_{IL}=0.4V$, except P4
Output voltage	V_{OH}	2.4	-	-	V	Push-pull, P4(high current PMOS), SOUND, $V_{DD}=2.7V$, $I_{OH}=-0.9mA$
		2.0	2.4	-	V	Push-pull, P4(low current PMOS), P8, $V_{DD}=2.7V$, $I_{OH}=-40\mu A$
	V_{OL}	-	0.15	0.3	V	$V_{DD}=2.7V$, $I_{OL}=0.9mA$
Leakage current	I_{LO}	-	-	1	μA	Open-drain, $V_{DD}=3.3V$, $V_O=3.3V$
Input resistor	R_{IN}	80	150	230	$K\Omega$	P0
		200	400	600	$K\Omega$	RESET
Frequency stability		-	15	-	%	$F_c=4MHz$, RC osc, $[F(3V)-F(2.4V)]/F(3V)$
Frequency variation		-	20	-	%	$F_c=4MHz$, $V_{DD}=3V$, RC osc, $[F(\text{typical})-F(\text{worse case})]/F(\text{typical})$

($V_{DD}=4.5\pm 0.5V$, $V_{SS}=0V$, $T_{OPR}=25^{\circ}C$)

Parameters	Sym.	Min.	Typ.	Max.	Unit	Conditions
Supply current	I_{DD}	-	1.5	2	mA	$V_{DD}=5.0V$, no load, NORMAL mode, $F_s=32KHz$ ($R=820k\Omega$), $F_c=4MHz$ (RC osc : $R=5.6K\Omega$, $C=20pF$)
		-	35	65	μA	$V_{DD}=5.0V$, no load, SLOW mode, $F_s=32KHz$ LCD on
		-	8	15	μA	$V_{DD}=5.0V$, IDLE mode, LCD off
		-	0.1	1	μA	$V_{DD}=5.0V$, STOP mode
Hysteresis voltage	V_{HYS+}	$0.50V_{DD}$	-	$0.75V_{DD}$	V	\overline{RESET} , P0, P8
	V_{HYS-}	$0.20V_{DD}$	-	$0.40V_{DD}$	V	
Input current	I_{IH}	-	-	± 1	μA	P0, \overline{RESET} , $V_{DD}=5.0V$, $V_{IH}=5.0/0V$
		-	-	± 1	μA	Open-drain, $V_{DD}=5.0V$, $V_{IH}=5.0/0V$
	I_{IL}	-	-	-1	mA	Push-pull, $V_{DD}=5.0V$, $V_{IL}=0.4V$, except P4
Output voltage	V_{OH}	3.0	-	-	V	Push-pull, P4(high current PMOS), SOUND, $V_{DD}=4.0V$, $I_{OH}=-4mA$
		2.4	-	-	V	Push-pull, P4(low current PMOS), P8, $V_{DD}=4.0V$, $I_{OH}=-200\mu A$
	V_{OL}	-	-	1	V	$V_{DD}=4.0V$, $I_{OL}=4mA$
Leakage current	I_{LO}	-	-	1	μA	Open-drain, $V_{DD}=5.0V$, $V_o=5.0V$
Input resistor	R_{IN}	40	75	120	$K\Omega$	P0
		100	200	300	$K\Omega$	\overline{RESET}
Frequency stability		-	15	-	%	$F_c=4MHz$, RC osc, $[F(4.5V)-F(3.6V)]/F(4.5V)$
Frequency variation		-	20	-	%	$F_c=4MHz$, $V_{DD}=4.5V$, RC osc, $[F(\text{typical})-F(\text{worse case})]/F(\text{typical})$

RESET PIN TYPE

TYPE RESET-A

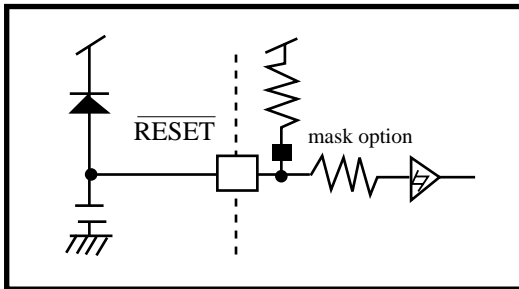

OSCILLATION PIN TYPE

TYPE OSC-B

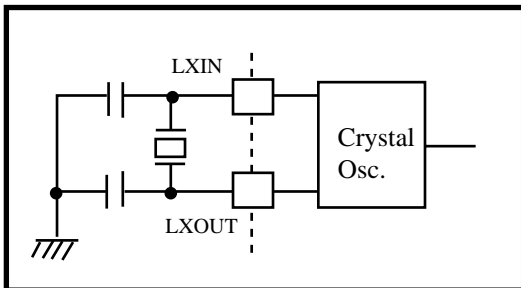

TYPE OSC-C

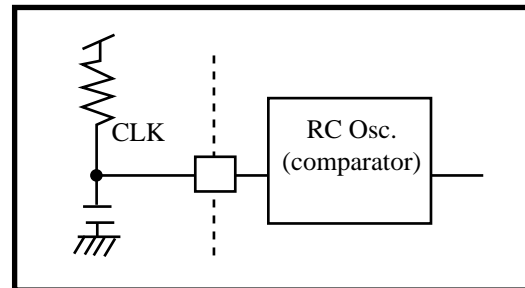

TYPE OSC-F

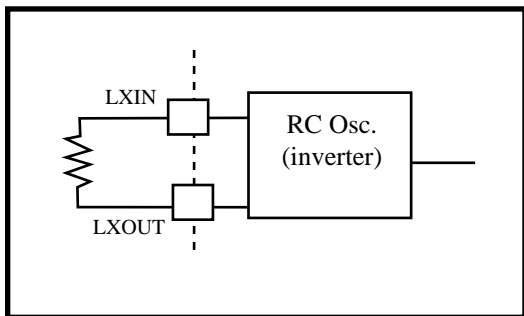

INPUT PIN TYPE

TYPE INPUT-A

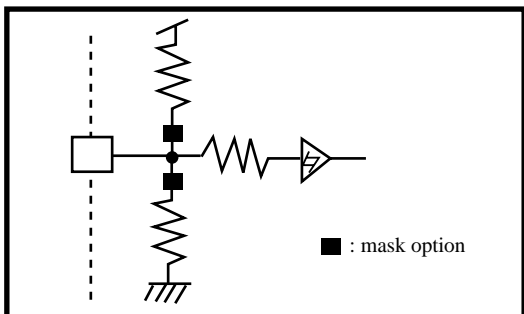

TYPE INPUT-B

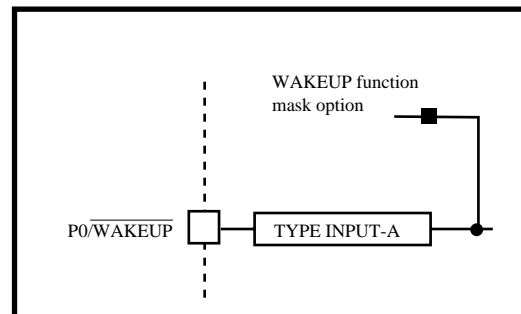

I/O PIN TYPE

TYPE I/O

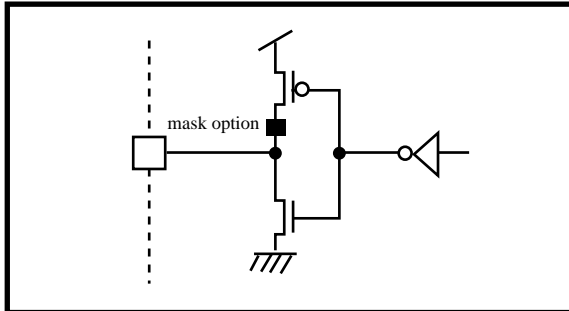

TYPE I/O-L

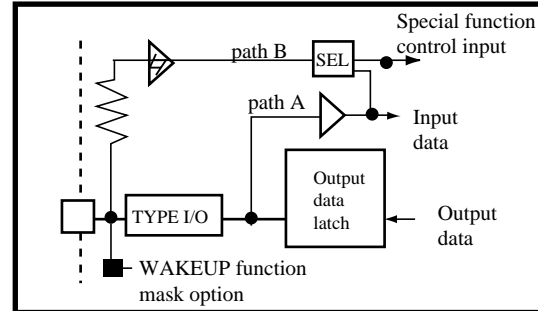

TYPE I/O-O

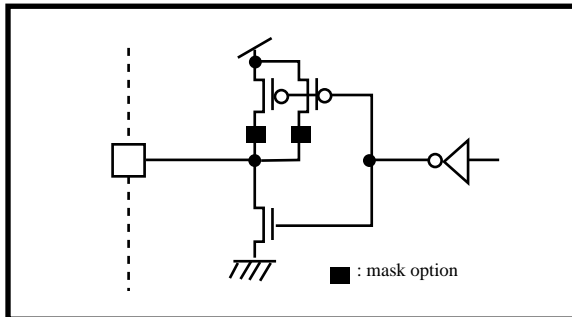

- Path A : For set and clear bit of port instructions, data goes through path A from output data latch to CPU.
- Path B : For input and test instructions, data from output pin go through path B to CPU and the output data latch will be set to high.

PAD DIAGRAM

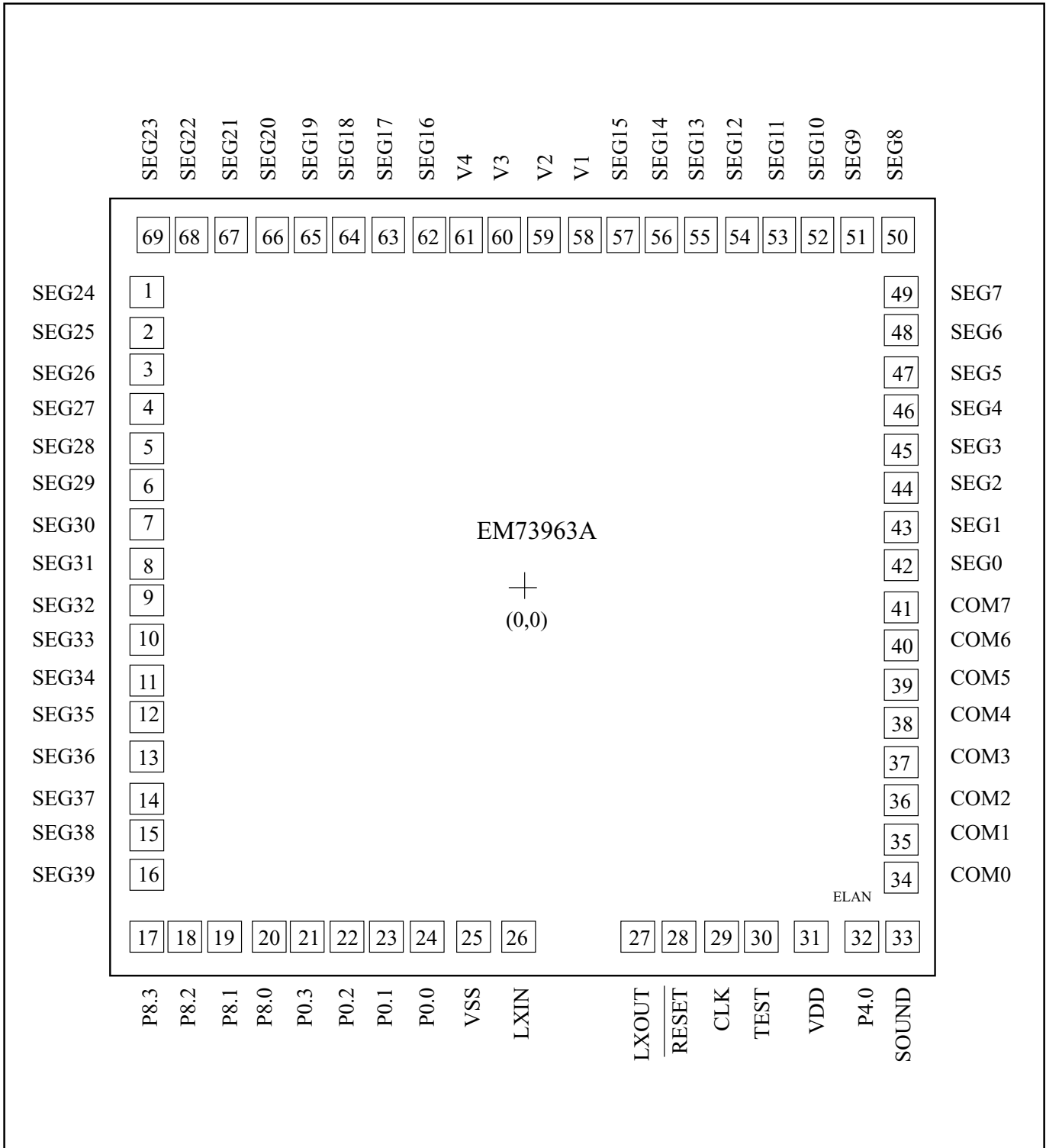

Pad No.	Symbol	X	Y
1	SEG24	-1153.5	903.0
2	SEG25	-1153.5	783.1
3	SEG26	-1153.5	663.2
4	SEG27	-1153.5	543.3
5	SEG28	-1153.5	423.4
6	SEG29	-1153.5	303.5
7	SEG30	-1153.5	183.6
8	SEG31	-1153.5	63.7
9	SEG32	-1153.5	-56.2
10	SEG33	-1153.5	-176.1
11	SEG34	-1153.5	-296.0
12	SEG35	-1153.5	-415.9
13	SEG36	-1153.5	-535.8
14	SEG37	-1153.5	-655.7
15	SEG38	-1153.5	-775.6
16	SEG39	-1153.5	-895.5
17	P8.3	-1157.6	-1077.5
18	P8.2	-1036.1	-1077.5
19	P8.1	-914.4	-1077.5
20	P8.0	-794.8	-1077.5
21	P0.3	-671.8	-1077.5
22	P0.2	-551.9	-1077.5
23	P0.1	-428.9	-1077.5
24	P0.0	-309.0	-1077.5
25	VSS	-161.3	-1077.5
26	LXIN	-17.8	-1077.5
27	LXOUT	354.3	-1077.5
28	RESET	480.9	-1077.5
29	CLK	600.8	-1077.5
30	TEST	722.8	-1077.5
31	VDD	879.4	-1077.5
32	P4.0	1035.0	-1077.5
33	SOUND	1158.1	-1077.5
34	COM0	1151.3	-895.5
35	COM1	1151.3	-775.6
36	COM2	1151.3	-655.7
37	COM3	1151.3	-535.8
38	COM4	1151.3	-415.9
39	COM5	1151.3	-296.0
40	COM6	1151.3	-176.1

Pad No.	Symbol	X	Y
41	COM7	1151.3	-56.2
42	SEG0	1151.3	63.7
43	SEG1	1151.3	183.6
44	SEG2	1151.3	303.5
45	SEG3	1151.3	423.4
46	SEG4	1151.3	543.3
47	SEG5	1151.3	663.2
48	SEG6	1151.3	783.1
49	SEG7	1151.3	903.0
50	SEG8	1138.1	1077.8
51	SEG9	1018.2	1077.8
52	SEG10	898.3	1077.8
53	SEG11	778.4	1077.8
54	SEG12	658.5	1077.8
55	SEG13	538.6	1077.8
56	SEG14	418.7	1077.8
57	SEG15	298.8	1077.8
58	V1	178.9	1077.8
59	V2	59.0	1077.8
60	V3	-60.9	1077.8
61	V4	-180.8	1077.8
62	SEG16	-300.7	1077.8
63	SEG17	-420.6	1077.8
64	SEG18	-540.5	1077.8
65	SEG19	-660.4	1077.8
66	SEG20	-780.3	1077.8
67	SEG21	-900.2	1077.8
68	SEG22	-1020.1	1077.8
69	SEG23	-1140.0	1077.8

Chip Size : 2620 x 2470 μm

Unit: μm

For PCB layout, IC substrate must be floated or connected to V_{SS} .

INSTRUCTION TABLE

(1) Data Transfer

Mnemonic	Object code (binary)	Operation description	Byte	Cycle	Flag		
					C	Z	S
LDA x	0110 1010 xxxx xxxx	Acc←RAM[x]	2	2	-	Z	1
LDAM	0101 1010	Acc←RAM[HL]	1	1	-	Z	1
LDAX	0110 0101	Acc←ROM[DP] _L	1	2	-	Z	1
LDAXI	0110 0111	Acc←ROM[DP] _H ,DP+1	1	2	-	Z	1
LDH #k	1001 kkkk	HR←k	1	1	-	-	1
LDHL x	0100 1110 xxxx xx00	LR←RAM[x],HR←RAM[x+1]	2	2	-	-	1
LDIA #k	1101 kkkk	Acc←k	1	1	-	Z	1
LDL #k	1000 kkkk	LR←k	1	1	-	-	1
STA x	0110 1001 xxxx xxxx	RAM[x]←Acc	2	2	-	-	1
STAM	0101 1001	RAM[HL]←Acc	1	1	-	-	1
STAMD	0111 1101	RAM[HL]←Acc, LR-1	1	1	-	Z	C
STAMI	0111 1111	RAM[HL]←Acc, LR+1	1	1	-	Z	C'
STD #k,y	0100 1000 kkkk yyyy	RAM[y]←k	2	2	-	-	1
STDMI #k	1010 kkkk	RAM[HL]←k, LR+1	1	1	-	Z	C'
THA	0111 0110	Acc←HR	1	1	-	Z	1
TLA	0111 0100	Acc←LR	1	1	-	Z	1

(2) Rotate

Mnemonic	Object code (binary)	Operation description	Byte	Cycle	Flag		
					C	Z	S
RLCA	0101 0000	←CF←Acc←	1	1	C	Z	C'
RRCA	0101 0001	→CF→Acc→	1	1	C	Z	C'

(3) Arithmetic operation

Mnemonic	Object code (binary)	Operation description	Byte	Cycle	Flag		
					C	Z	S
ADCAM	0111 0000	Acc←Acc + RAM[HL] + CF	1	1	C	Z	C'
ADD #k,y	0100 1001 kkkk yyyy	RAM[y]←RAM[y] +k	2	2	-	Z	C'
ADDA #k	0110 1110 0101 kkkk	Acc←Acc+k	2	2	-	Z	C'
ADDAM	0111 0001	Acc←Acc + RAM[HL]	1	1	-	Z	C'
ADDH #k	0110 1110 1001 kkkk	HR←HR+k	2	2	-	Z	C'
ADDL #k	0110 1110 0001 kkkk	LR←LR+k	2	2	-	Z	C'
ADDM #k	0110 1110 1101 kkkk	RAM[HL]←RAM[HL] +k	2	2	-	Z	C'
DECA	0101 1100	Acc←Acc-1	1	1	-	Z	C
DECL	0111 1100	LR←LR-1	1	1	-	Z	C
DECM	0101 1101	RAM[HL]←RAM[HL] -1	1	1	-	Z	C
INCA	0101 1110	Acc←Acc + 1	1	1	-	Z	C'

INCL	0111 1110	LR←LR + 1	1	1	-	Z	C'
INCM	0101 1111	RAM[HL]←RAM[HL]+1	1	1	-	Z	C'
SUBA #k	0110 1110 0111 kkkk	Acc←k-Acc	2	2	-	Z	C
SBCAM	0111 0010	Acc←RAM[HL] - Acc - CF'	1	1	C	Z	C
SUBM #k	0110 1110 1111 kkkk	RAM[HL]←k - RAM[HL]	2	2	-	Z	C

(4) Logical operation

Mnemonic	Object code (binary)	Operation description	Byte	Cycle	Flag		
					C	Z	S
ANDA #k	0110 1110 0110 kkkk	Acc←Acc&k	2	2	-	Z	Z'
ANDAM	0111 1011	Acc←Acc & RAM[HL]	1	1	-	Z	Z'
ANDM #k	0110 1110 1110 kkkk	RAM[HL]←RAM[HL]&k	2	2	-	Z	Z'
ORA #k	0110 1110 0100 kkkk	Acc←Acc k	2	2	-	Z	Z'
ORAM	0111 1000	Acc ← Acc RAM[HL]	1	1	-	Z	Z'
ORM #k	0110 1110 1100 kkkk	RAM[HL]←RAM[HL] k	2	2	-	Z	Z'
XORAM	0111 1001	Acc←Acc^RAM[HL]	1	1	-	Z	Z'

(5) Exchange

Mnemonic	Object code (binary)	Operation description	Byte	Cycle	Flag		
					C	Z	S
EXA x	0110 1000 xxxx xxxx	Acc↔RAM[x]	2	2	-	Z	1
EXAH	0110 0110	Acc↔HR	1	2	-	Z	1
EXAL	0110 0100	Acc↔LR	1	2	-	Z	1
EXAM	0101 1000	Acc↔RAM[HL]	1	1	-	Z	1
EXHL x	0100 1100 xxxx xx00	LR↔RAM[x], HR↔RAM[x+1]	2	2	-	-	1

(6) Branch

Mnemonic	Object code (binary)	Operation description	Byte	Cycle	Flag		
					C	Z	S
SBR a	00aa aaaa	If SF=1 then PC←PC ₁₂₋₆ .a ₅₋₀ else null	1	1	-	-	1
LBR a	1100 aaaa aaaa aaaa	If SF= 1 then PC←a else null	2	2	-	-	1
SLBR a	0101 0101 1100 aaaa aaaa aaaa (a:1000~1FFFh) 0101 0111 1100 aaaa aaaa aaaa (a:0000~0FFFh)	If SF=1 then PC←a else null	3	3	-	-	1

(7) Compare

Mnemonic	Object code (binary)	Operation description	Byte	Cycle	Flag		
					C	Z	S
CMP #k,y	0100 1011 kkkk yyyy	k-RAM[y]	2	2	C	Z	Z'
CMPA x	0110 1011 xxxx xxxx	RAM[x]-Acc	2	2	C	Z	Z'

Mnemonic	Object code (binary)	Operation description	Byte	Cycle	Flag		
					C	Z	S
CMPAM	0111 0011	RAM[HL] - Acc	1	1	C	Z	Z'
CMPH #k	0110 1110 1011 kkkk	k - HR	2	2	-	Z	C
CMPIA #k	1011 kkkk	k - Acc	1	1	C	Z	Z'
CMPL #k	0110 1110 0011 kkkk	k-LR	2	2	-	Z	C

(8) Bit manipulation

Mnemonic	Object code (binary)	Operation description	Byte	Cycle	Flag		
					C	Z	S
CLM b	1111 00bb	RAM[HL] _b ←0	1	1	-	-	1
CLP p,b	0110 1101 11bb pppp	PORT[p] _b ←0	2	2	-	-	1
CLPL	0110 0000	PORT[LR ₃₋₂ +4]LR ₁₋₀ ←0	1	2	-	-	1
CLR y,b	0110 1100 11bb yyyy	RAM[y] _b ←0	2	2	-	-	1
SEM b	1111 01bb	RAM[HL] _b ←1	1	1	-	-	1
SEP p,b	0110 1101 01bb pppp	PORT[p] _b ←1	2	2	-	-	1
SEPL	0110 0010	PORT[LR ₃₋₂ +4]LR ₁₋₀ ←1	1	2	-	-	1
SET y,b	0110 1100 01bb yyyy	RAM[y] _b ←1	2	2	-	-	1
TF y,b	0110 1100 00bb yyyy	SF←RAM[y] _b '	2	2	-	-	*
TFA b	1111 10bb	SF←Acc _b '	1	1	-	-	*
TFM b	1111 11bb	SF←RAM[HL] _b '	1	1	-	-	*
TFP p,b	0110 1101 00bb pppp	SF←PORT[p] _b '	2	2	-	-	*
TFPL	0110 0001	SF←PORT[LR ₃₋₂ +4]LR ₁₋₀ '	1	2	-	-	*
TT y,b	0110 1100 10bb yyyy	SF←RAM[y] _b	2	2	-	-	*
TTP p,b	0110 1101 10bb pppp	SF←PORT[p] _b	2	2	-	-	*

(9) Subroutine

Mnemonic	Object code (binary)	Operation description	Byte	Cycle	Flag		
					C	Z	S
LCALL a	0100 0aaa aaaa aaaa	STACK[SP]←PC, SP←SP -1, PC←a	2	2	-	-	-
SCALL a	1110 nnnn	STACK[SP]←PC, SP←SP - 1, PC←a, a = 8n + 6 (n =1~15),0086h (n = 0)	1	2	-	-	-
RET	0100 1111	SP←SP + 1, PC←STACK[SP]	1	2	-	-	-

(10) Input/output

Mnemonic	Object code (binary)	Operation description	Byte	Cycle	Flag		
					C	Z	S
INA p	0110 1111 0100 pppp	Acc←PORT[p]	2	2	-	Z	Z'
INM p	0110 1111 1100 pppp	RAM[HL]←PORT[p]	2	2	-	-	Z'
OUT #k,p	0100 1010 kkkk pppp	PORT[p]←k	2	2	-	-	1
OUTA p	0110 1111 000p pppp	PORT[p]←Acc	2	2	-	-	1
OUTM p	0110 1111 100p pppp	PORT[p]←RAM[HL]	2	2	-	-	1

(11) Flag manipulation

Mnemonic	Object code (binary)	Operation description	Byte	Cycle	Flag		
					C	Z	S
TFCFC	0101 0011	SF←CF', CF←0	1	1	0	-	*
TTCFS	0101 0010	SF←CF, CF←1	1	1	1	-	*
TZS	0101 1011	SF←ZF	1	1	-	-	*

(12) Interrupt control

Mnemonic	Object code (binary)	Operation description	Byte	Cycle	Flag		
					C	Z	S
CIL r	0110 0011 11rr rrrr	IL←IL & r	2	2	-	-	1
DICIL r	0110 0011 10rr rrrr	EIF←0,IL←IL&r	2	2	-	-	1
EICIL r	0110 0011 01rr rrrr	EIF←1,IL←IL&r	2	2	-	-	1
EXAE	0111 0101	MASK↔Acc	1	1	-	-	1
RTI	0100 1101	SP←SP+1,FLAG.PC ←STACK[SP],EIF ←1	1	2	*	*	*

(13) CPU control

Mnemonic	Object code (binary)	Operation description	Byte	Cycle	Flag		
					C	Z	S
NOP	0101 0110	no operation	1	1	-	-	-

(14) Timer/Counter & Data pointer & Stack pointer control

Mnemonic	Object code (binary)	Operation description	Byte	Cycle	Flag		
					C	Z	S
LDADPL	0110 1010 1111 1100	Acc←[DP] _L	2	2	-	Z	1
LDADPM	0110 1010 1111 1101	Acc←[DP] _M	2	2	-	Z	1
LDADPH	0110 1010 1111 1110	Acc←[DP] _H	2	2	-	Z	1
LDASP	0110 1010 1111 1111	Acc←SP	2	2	-	Z	1
LDATAL	0110 1010 1111 0100	Acc←[TA] _L	2	2	-	Z	1
LDATAM	0110 1010 1111 0101	Acc←[TA] _M	2	2	-	Z	1
LDATAH	0110 1010 1111 0110	Acc←[TA] _H	2	2	-	Z	1
LDATBL	0110 1010 1111 1000	Acc←[TB] _L	2	2	-	Z	1
LDATBM	0110 1010 1111 1001	Acc←[TB] _M	2	2	-	Z	1
LDATBH	0110 1010 1111 1010	Acc←[TB] _H	2	2	-	Z	1
STADPL	0110 1001 1111 1100	[DP] _L ←Acc	2	2	-	-	1
STADPM	0110 1001 1111 1101	[DP] _M ←Acc	2	2	-	-	1
STADPH	0110 1001 1111 1110	[DP] _H ←Acc	2	2	-	-	1
STASP	0110 1001 1111 1111	SP←Acc	2	2	-	-	1
STATAL	0110 1001 1111 0100	[TA] _L ←Acc	2	2	-	-	1
STATAM	0110 1001 1111 0101	[TA] _M ←Acc	2	2	-	-	1
STATAH	0110 1001 1111 0110	[TA] _H ←Acc	2	2	-	-	1
STATBL	0110 1001 1111 1000	[TB] _L ←Acc	2	2	-	-	1
STATBM	0110 1001 1111 1001	[TB] _M ←Acc	2	2	-	-	1
STATBH	0110 1001 1111 1010	[TB] _H ←Acc	2	2	-	-	1

* This specification are subject to be changed without notice.

****** SYMBOL DESCRIPTION**

Symbol	Description	Symbol	Description
HR	H register	LR	L register
PC	Program counter	DP	Data pointer
SP	Stack pointer	STACK[SP]	Stack specified by SP
A _{CC}	Accumulator	FLAG	All flags
CF	Carry flag	ZF	Zero flag
SF	Status flag	EI	Enable interrupt register
IL	Interrupt latch	MASK	Interrupt mask
PORT[p]	Port (address : p)	TA	Timer/counter A
TB	Timer/counter B	RAM[HL]	Data memory (address : HL)
RAM[x]	Data memory (address : x)	ROM[DP] _L	Low 4-bit of program memory
ROM[DP] _H	High 4-bit of program memory	[DP] _L	Low 4-bit of data pointer register
[DP] _M	Middle 4-bit of data pointer register	[DP] _H	High 4-bit of data pointer register
[TA] _L ([TB] _L)	Low 4-bit of timer/counter A (timer/counter B) register	[TA] _M ([TB] _M)	Middle 4-bit of timer/counter A (timer/counter B) register
[TA] _H ([TB] _H)	High 4-bit of timer/counter A (timer/counter B) register	LR ₁₋₀	Contents of bit assigned by bit 1 to 0 of LR
LR ₃₋₂	Bit 3 to 2 of LR	a ₅₋₀	Bit 5 to 0 of destination address for branch instruction
PC ₁₂₋₆	Bit 12 to 6 of program counter	←	Transfer
↔	Exchange	+	Addition
-	Substraction	&	Logic AND
	Logic OR	^	Logic XOR
!	Inverse operation	.	Concatenation
#k	4-bit immediate data	x	8-bit RAM address
y	4-bit zero-page address	p	4-bit or 5-bit port address
b	Bit address	r	6-bit interrupt latch