

Preliminary

GENERAL DESCRIPTION

The EM83812 PnP Scrolling Mouse Controller is specially designed to control serial mouse device. This single chip can interface three key-switches and 4 X-Y photo-couples plus Z-axis directly to RS-232C. There are four types Z-axis inputs used to implement scrolling mouse functionality.

FEATURES

- Using 50kΩ ±1% resistor for RC oscillation.
- Compatible with Microsoft serial scrolling mouse.
- 100 bytes PnP ID code could be filled by code layer.
- Built-in noise immunity circuit.
- The sampling rate of motion detector is up to 65KHz.
- Built-in three zener diodes : one in VDD to VSS, two in RTS to VDD.
- CMOS push-pull RXD output.
- Built-in current comparator for photo-couples input.
- Built-in three step dynamic input impedance.
- Three key-switches and four photo-couples inputs.
- RTS debouncing circuit included.
- Photo couple test mode included.
- Low power dissipation.
- Six types Z direction input:

1. Photo couples input. (Z/1)	4. Mechanical input. (Z/1)
2. Key-switches input.	5. Photo couples input. (Z/4)
3. Voltage-sensing input.	6. Mechanical input. (Z/2)
- Package type:

EM83812AP : 16DIP, Photo couples input. (Z/1)	EM83812DP: 16DIP, Mechanical input. (Z/1)
EM83812BP : 16DIP, Key-switches input.	EM83812EP : 16DIP, Photo couples input. (Z/4)
EM83812CP : 16DIP, Voltage-sensing input.	EM83812FP : 16DIP, Mechanical input. (Z/2)

APPLICATION

- Serial PnP scrolling mouse.

PIN ASSIGNMENT

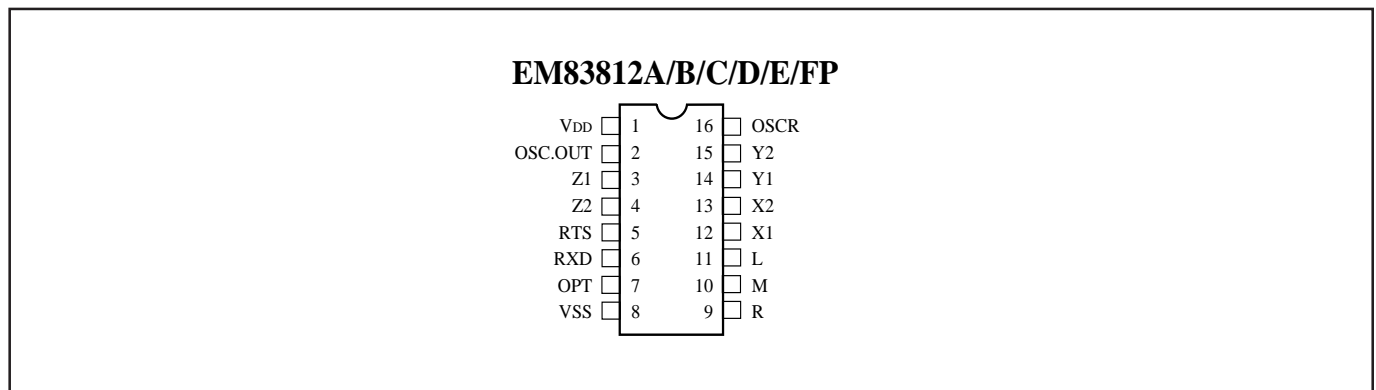

Preliminary

FUNCTIONAL BLOCK DIAGRAM

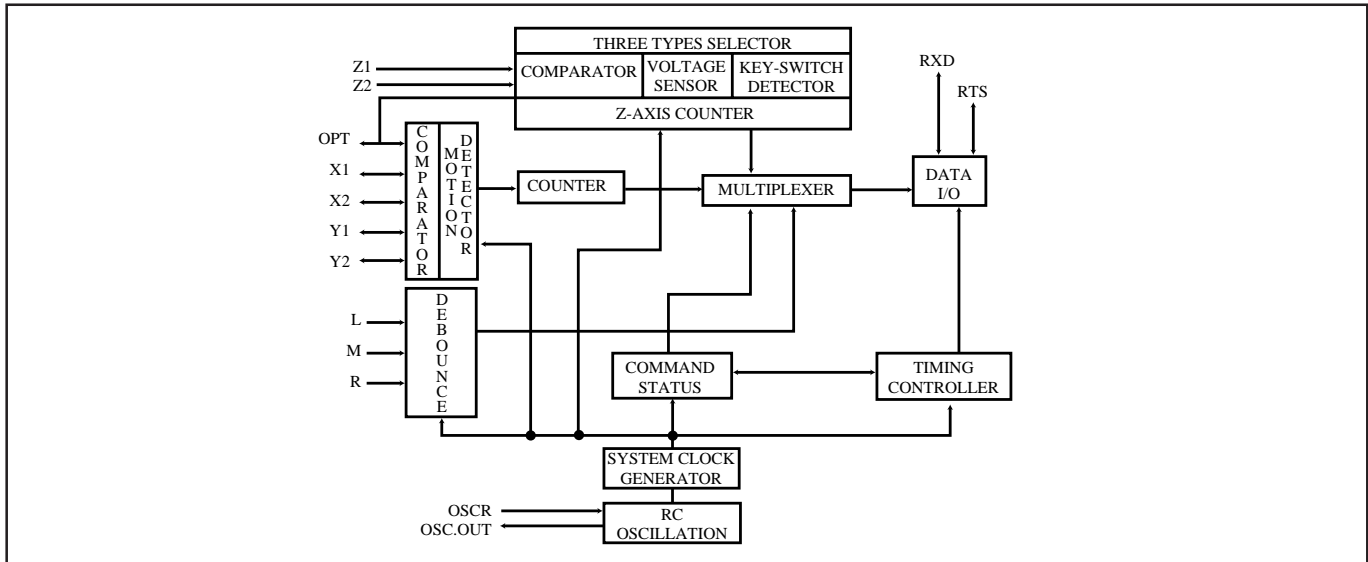

PIN DESCRIPTIONS

Symbol	I/O	Function
OPT	I/O	INPUT: 200kohm pull low to VSS. When OPT is connected to VDD, EM84520 will enter test mode. In test mode, L will be the output of X1, while M will be the output of X2. Toggling R key can change these output to be Y1, Y2 or Z1, Z2 respectively. OUTPUT: 2kHz Z-axis LED driving source with A/D/E/F version. "1"= VDD, "0"= floating High duty is about 60us.
OSC.OUT	O	The RC oscillation clock output. Or 3mA sink current output for X, Y photo emitters.
OSCR	I	Connect 50kΩ±1% precise resistor for oscillation.
RTS	I/O	±12V signal with 10mA driving. Used as PnP ID code output trigger signal from 10w (-12V) to high (+12V) while under normal operating. RTS will keep on ±12V driving.
RXD	I/O	One report contains 4 data bytes, 7 data bits without parity in the data byte. The data byte is shifted out from LSB through MSB, started by start bit and ended by stop bit. The RXD signal swing between +6V and -6V.
R	I	Three key-switches inputs. 200kΩ resistor pull low.
M	I/O	In Z-axis key mode, M key toggling can change the scrolling speed from low to high.
L	I/O	
X1	I	Three step dynamic input impedance. If OSC.OUT is not connected to LEDs, the dynamic input impedance will be off.
X2	I	
Y1	I	Use current comparator to measure photo-couples "ON", or "OFF".
Y2	I	
Z1	I	Z-axis input.
Z2	I	Photo mode : Three steps dynamic input impedance. Current comparator input. Key mode : 200 kΩ resistor pull low. 7 levels increased by "M" key. Voltage mode : 200 kΩ resistor pull low. 7 levels voltage comparator. Mechanical mode : 13.2kΩ resistor pull low. Current comparator input.
VSS		Negative power.
VDD		Power line.

Preliminary

FUNCTION DESCRIPTIONS

(I) Serial Scrolling Mouse :

In Microsoft mode, the transmission cycle consists of four bytes in one report. Each byte contains one start bit, 7 data bits and two stop bits. The first byte contains "L", "R" key status and four bits of the two most significant bits in horizontal counter and vertical counter. The second byte represents the value accumulated by horizontal counter, the third byte is the data of the vertical counter. The last byte contains "M" key status and Z-axis value. The vertical data is transmitted in 2's complement.

Output byte arrange

Bit no.	6	5	4	3	2	1	0
1st byte	1	L	R	V7'	V6'	H7	H6
2nd byte	0	H5	H4	H3	H2	H1	H0
3rd byte	0	V5'	V4'	V3'	V2'	V1'	V0'
4th byte	0	0	M	Z3	Z2	Z1	Z0

Plug & Play ID code

When RTS input from low to high, EM84520 will send a string ID code. Customer can specify the contains of the code area and the total length below 100 bytes by changing the code layer.

Field Name	Length	Field Data	Description
Other ID	<17	4D, 5A, 40, 00, 00, 00	ID for legacy
Begin ID	1	08	Begin PnP ID
PnP Revision	2	01, 24	Version 1.00
EISA ID	3	25, 2D, 23	EMC
Product ID	4	10, 10, 10, 11	0001
Serial Number	9	3C	None provided
Class ID	<34	3C, 2D, 2F, 35, 33, 25	Mouse Class
Driver ID	<42	3C, 30, 2E, 30, 10 26, 10, 21	PnP0F0A
User Name	<42	3C, 25, 2D, 23, 00, 33, 23, 32, 2F, 2C, 2C, 29, 2E, 27, 00, 33, 25, 32, 29, 21, 2C, 00, 2D, 2F, 35, 33, 25	EMC SCROLLING SERIAL MOUSE
Check sum	2	21, 15	2 bytes checks um
End PnP	1	09	End PnP ID

(II). Z-axis Input Function :

- (a) Photo couples input : Z-axis counter accumulates the Z1, Z2 phase changed by movement.
- (b) Key-switches input : Pressing Z1, Z2 will start to fill the Z-axis counter with the value beginning at one. Toggling "M" key can increase the value any time by one. The limit value is ± 7 .
- (c) The relationship between the value and the transmission rate as follows :

Preliminary

Value	Rate per second
1	2.7
2	6.4
3	9.2
4	12.8
5	15
6	18
7	20

- (d) Voltage-sensing mode : There are 7 voltage levels in Z1, Z2 input. The transmission table is the same as key-switches mode. The relationship between the value of Z-axis counter and the voltage as follows :

Value	Voltage
0	1V↓
1	1.0V-1.6V
2	1.6V-2.2V
3	2.2V-2.8V
4	2.8V-3.4V
5	3.4V-4.0V
6	4.0V-4.6V
7	4.6V↑

Under $V_{DD}=5V$ condition.

- (e) Mechanical mode : The same as optical wheel mode.



Preliminary

ABSOLUTE MAXIMUM RATINGS

Parameter	Ratings		Unit
	Min.	Max.	
Temperature under bias	0	70	°C
Storage temperature range	-65	150	°C
Supply voltage	-0.3	7.5	V
Power dissipation	-	500	mW

DC ELECTRICAL CHARACTERISTICS (T_A=25°C to 70°C, V_{ds}=5.6V)

Parameters	Sym.	Min.	Typ.	Max.	Unit
Operating voltage	Vdd	4.5	6	6.5	V
	Vrts	-	12	13	V
Operating current (Vdd=5.4, RTS=Vdd)	Iop1	-	-	0.8	mA
Operating current (Vdd=6.2, RTS=Vdd)	Iop2	3	-	-	mA
RTS Operating current (Vdd=5.6, RTS=11V)	Irts1	-	-	1.8	mA
RTS operating current (Vdd=5.6, RTS=12V)	Irts2	4	-	-	mA
RXD high output voltage (Vrh=Vrts=2.6V)	Irh	2	-	-	mA
RXD low output voltage (Vrh=Vss+2.6V)	Irl	-	-	-2	mA
RTS high input voltage	Vrts+	9.6	-	-	V
RTS low input voltage	Vrts-	-	-	6.8	V
X1,X2,Y1,Y2,Z1,Z2 (photo mode) low input reference current	Ipl	70	-	-	μA
X1,X2,Y1,Y2,Z1,Z2 (photo mode) high input reference current	Iph	-	-	106	μA
X1,X2,Y1,Y2,Z1,Z2 (photo mode) input current (input impedance) (80μA)	Vpl1	0.8	-	1.2	V
X1,X2,Y1,Y2,Z1,Z2 (photo mode) input current (input impedance) (500μA)	Vpl2	1.5	-	2.1	V
L,M,R,OPT,Z1,Z2 (key mode) input low voltage	Vail	-	-	1.5	V
Z1,Z2 (key mode) input high voltage	Vaih	3.5	-	-	V
Z1,Z2 (voltage mode) sensitivity	Vs	-0.3	-	+0.3	V
L,M,R,Z1,Z2 (key & voltage mode) input current (Vds=5.6V)	Imi	18	-	56	μA
OPT input current	Ixi	-18	-	-56	μA
OPT high output current (Iopt=20mA)	Idc	4.5	-	-	V
L,M,R,X1,X2,Y1,Y2,Z1,Z2 input leakage current (Vds=0V)	Iil	0	-	-1.0	μA
OPT input leakage current (Vds=5.6V)	Iih	0	-	1.0	μA

* All voltage in above table are compared with VSS.

* This specification are subject to be changed without notice.

*Preliminary*AC ELECTRICAL CHARACTERISTICS ($T_A=0^{\circ}\text{C}$ to 70°C)

Parameters	Sym.	Min.	Typ.	Max.	Unit
Oscillating Frequency	Fosc	-3.3%	32.40	+3.3%	KHz
Key Debounce	Tkd	-	13	-	ms
Transmission time	Tmx	-	33.33	.	ms
Start bit time	Ts	-	833.3	-	us
Data bit time	Td	-	833.3	-	us
Stop bit time	Tp	-	833.3	-	us
Mode code delay time	Trd	11	-	14	ms
Rising Edge Crossed Wid	Tr	15.4	-	-	us
Falling Edge Crossed Wid	Tf	15.4	-	-	us

Preliminary

TIMING DIAGRAM

(A) RXD output :

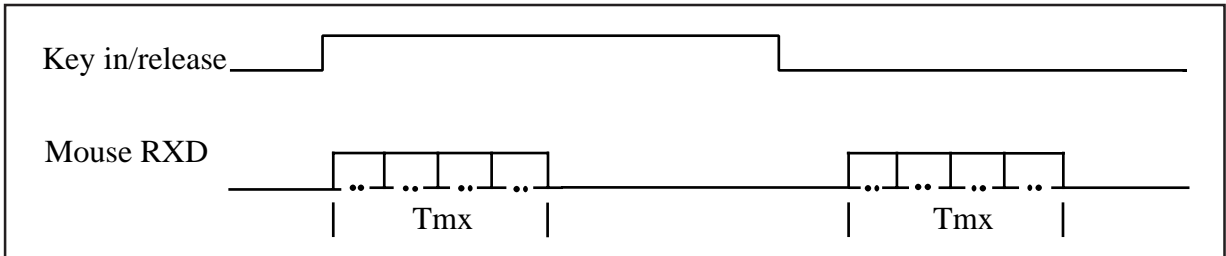

(B) Bytes structure :

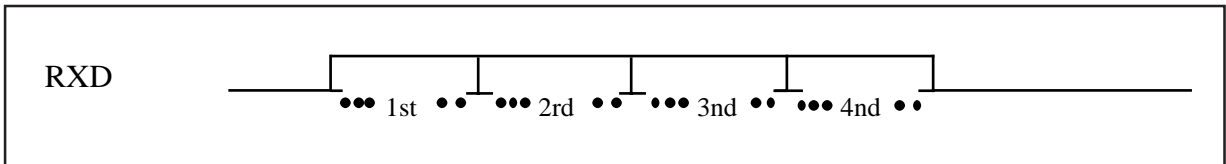

(C) Bits structure :

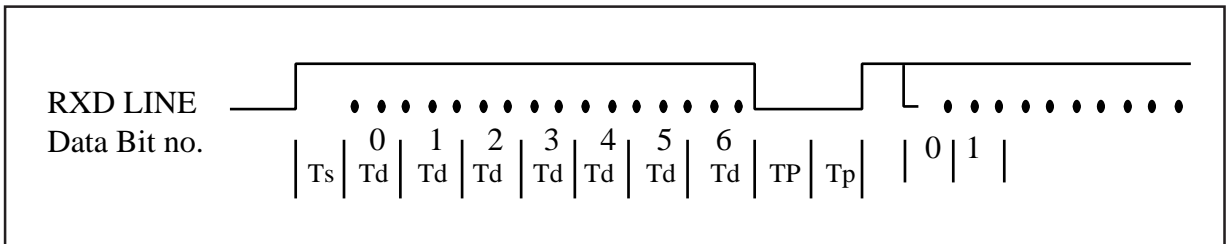

(D) PnP ID code echo timing :

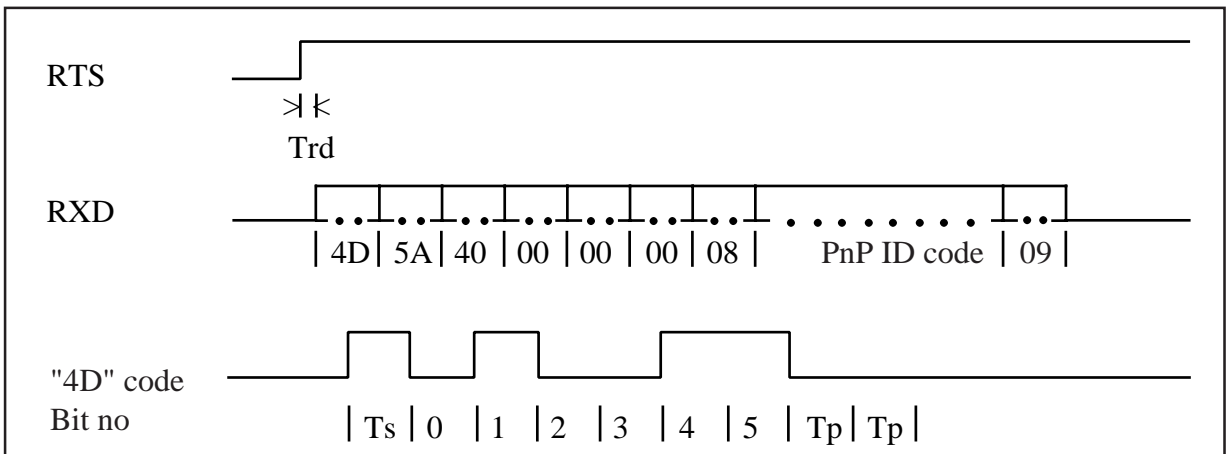

Preliminary

APPLICATION CIRCUIT

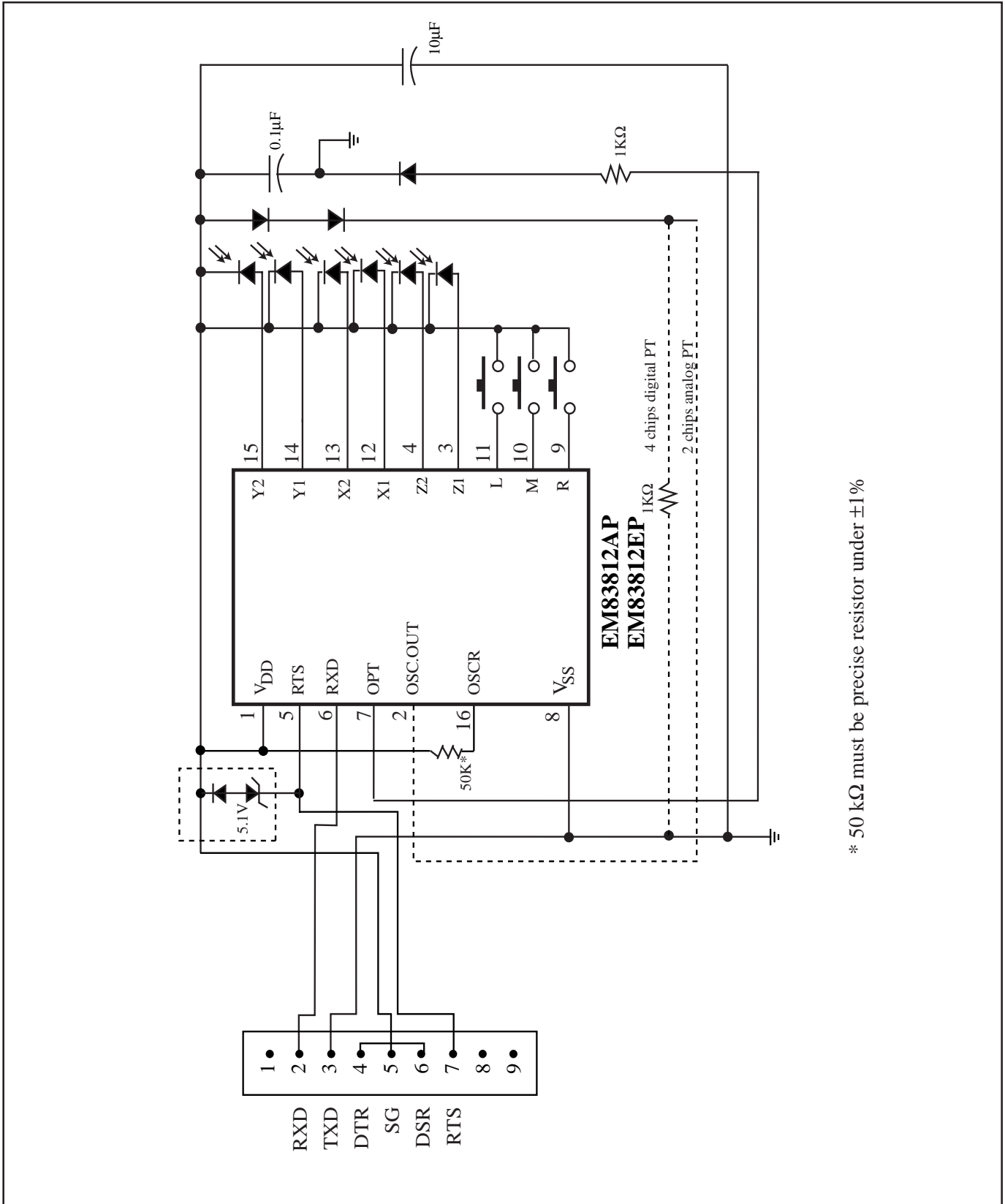

* 50 kΩ must be precise resistor under ±1%

Preliminary

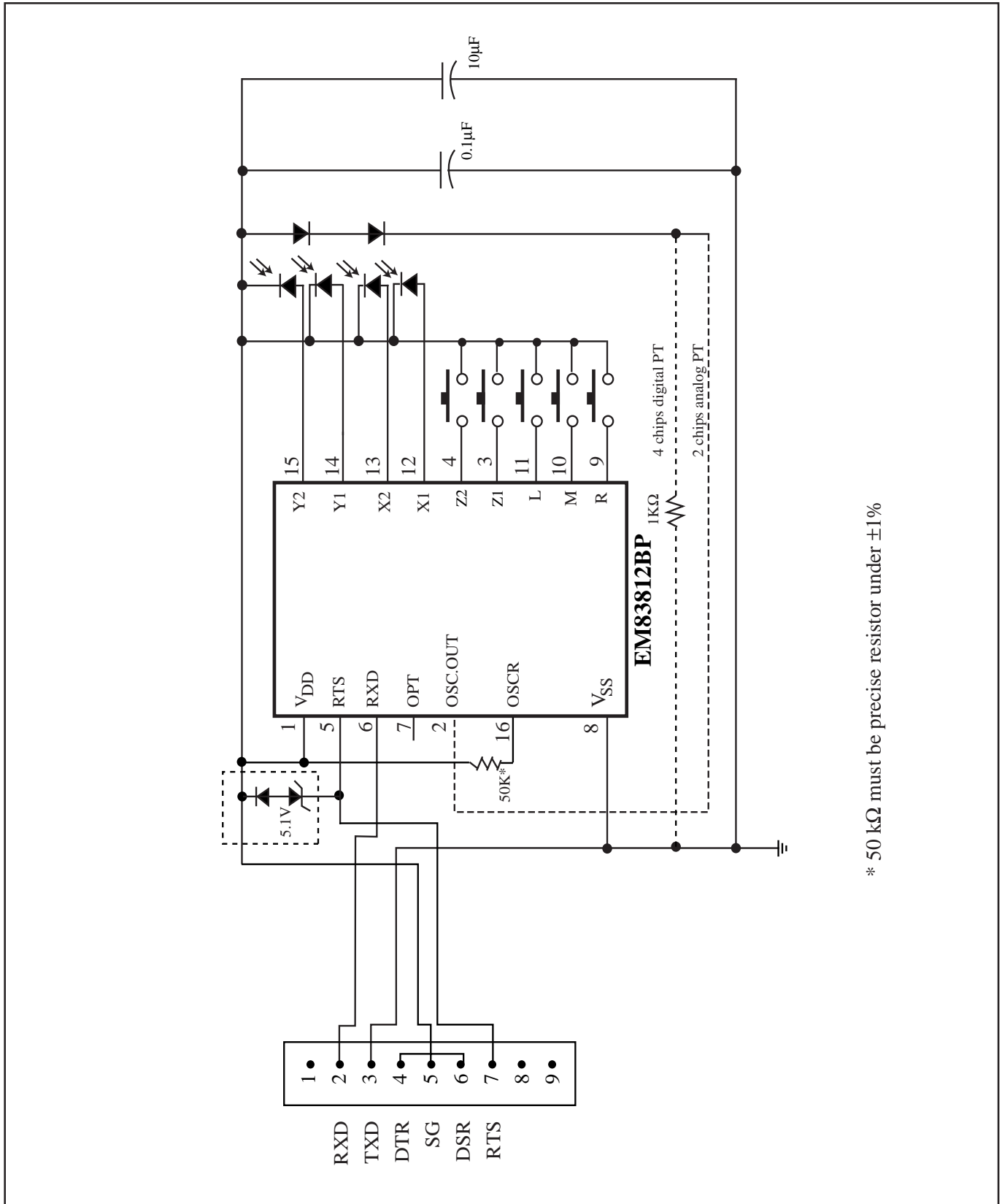

* 50 kΩ must be precise resistor under ±1%

Preliminary

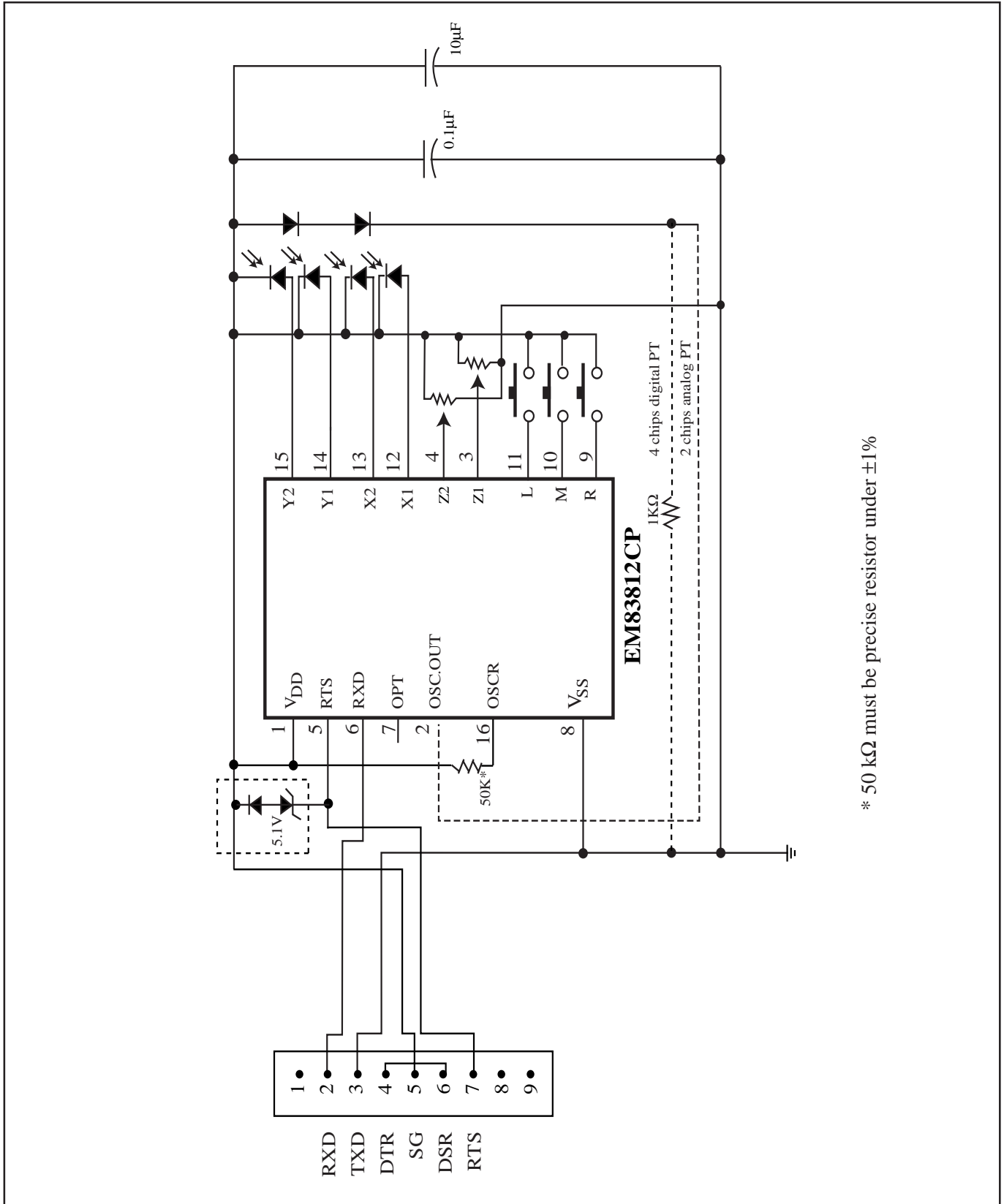

* 50 kΩ must be precise resistor under ±1%

Preliminary

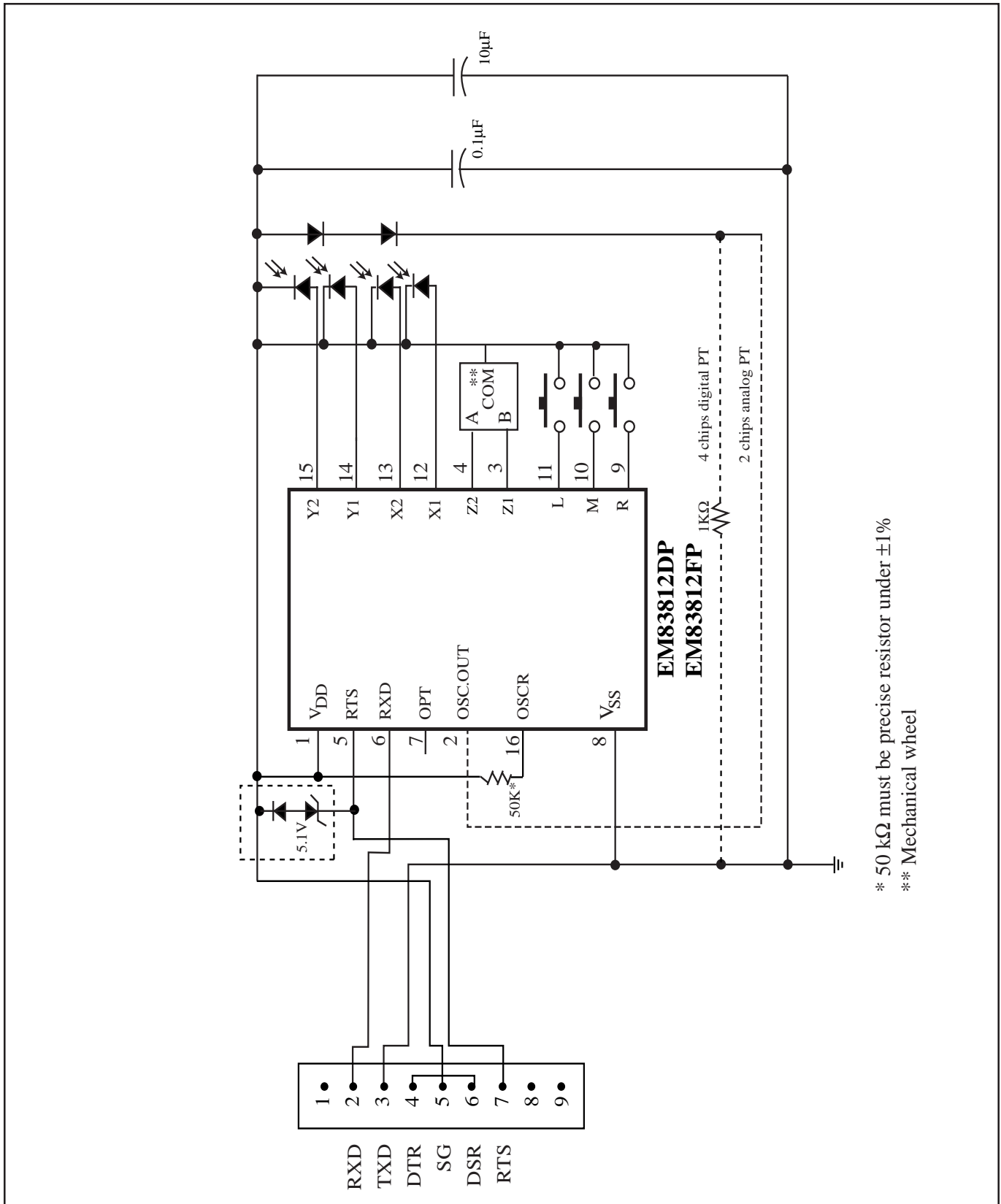

* 50 k Ω must be precise resistor under $\pm 1\%$
 ** Mechanical wheel