

GENERAL DESCRIPTION

The EMC ADB Mouse Controller is a mouse controller for apple mouse system.

The following functions are supported:

- Controller receives command or data from Host.
- Controller transmits data to Host.

FEATURES

- Two-button mouse and trackball controller.
- Key Lock function is available.
- Both photo discharge and non-discharge modes are available.
- Discharge mode can reduce X,Y DC offset level.
- Dynamic LEDs Control to reduce system power consumption.
- Four stages sample rate at 1KHz,2.5KHz,5KHz,10KHz.
- Include Noise Immunity methodology to avoid false entry.
- Operating frequency at 3.58MHz.
- 18 Pin DIP.

PIN ASSIGNMENTS

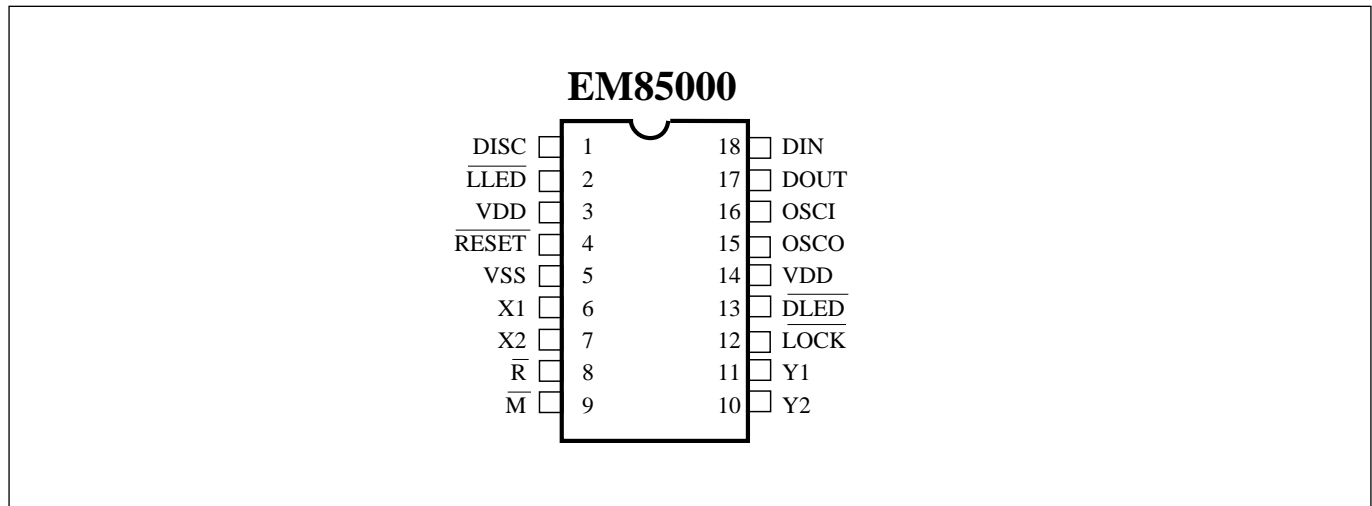

**PIN DESCRIPTIONS**

Symbol	I/O	Function
DISC	I	H=discharge mode,L=non-discharge mode.(internal pull low)
LLED	O	Trackball lock led display.
V _{DD}	-	+5v power.
RESET	I	Low active for chip reset.
V _{SS}	-	GND.
X1,X2	I	Horizontal direction status for x counter data.
R̄	I	Right mouse key. (internal pull high)
M̄	I	Main mouse key. (internal pull high)
Y1,Y2	I	Vertical direction status for y counter data.
LOCK	I	Optional trackball key lock button to lock /M key. (internal pull high)
DLED	O	Active low to turn on photo LEDs.
OSCO	O	Crystal clock output.
OSCI	I	Crystal clock input.
DOUT	O	Transmit data to Host.(open drain)
DIN	I	Receive data or command from Host.

FUNCTION DESCRIPTIONS

The ADB Mouse Controller is communicated with Host by the ADB bus. Only Host sends command to mouse controller, the mouse doesn't send any command to the other devices or Host on the bus. The signal of the data or command is transmitted by asynchronous protocol. First, Host sends Attention and Sync signals to synchronize all devices on the bus, then sends command or data according the command defined.

If the address which the device receives in command is the same as the device address, then the device will execute this command. If there are more than two devices to contend the ADB bus, then the bus collision will happen. Therefore, every devices must have capability to detect and to solve collision. On the contrary, if the address in the command is not the same with the address in the device, the device will discard the command, or sends SRQ signal to Host when device has data to be send.

COMMANDS

COMMAND	B7	B6	B5	B4	B3	B2	B1	B0	DESCRIPTION
FLUSH	A3	A2	A1	A0	0	0	0	1	Mouse will clear all X,Y counter data(R0=0).
SENDRESET	-	-	-	-	0	0	0	0	Soft Reset(equal power-on reset).
TALK	A3	A2	A1	A0	1	1	Rh	Rl	Controller transmits data to Host.
LISTEN	A3	A2	A1	A0	1	0	Rh	Rl	Controller receives data from Host.
OTHER	-----								Reserved command.

1. B7 ~ B4: Device Address(0~F) is the position of the device. (Ref table 2)
2. B0 ~ B1: Selected Register(R0~R3), each register has two bytes.
R0: Mouse counter data register (read only by Host)
R3: Control register (can be read or written by Host)
R1, R2: No use in mouse.
3. B3, B2=11: TALK command. (1 byte)
TALK R0: IF mouse has data to report, mouse will send two bytes (R0) to Host.
IF mouse has't data to report, Host will continue polling(R0) or execute other command.
TALK R3: Host can read mouse R3 register (2 bytes).
TALK R1, R2: No use in mouse.

4.B3,B2=10:LISTEN command.(3 bytes)
 LISTEN R3:Host writes controll status to mouse R3.
 LISTEN R0 ~R2:No use in mouse.
 Host must send 3 bytes. (1 byte command and 2 bytes register data to mouse R3)

TABLE 1

DEVICE ADDRESS

Device Address	Device Type	Addressing	Example
0	Reserved	Extended	
1	Appliances	Extended	
2	Encoded Device	Movable	Keyboard address for initial address.
3	Relative Device	Movable	Mouse address for initial address.
4	Absolute Device	Movable	Tablet address for initial address.
5	Reserved	-----	
6	Reserved	-----	
7	Reserved	-----	
8 ~ F	Soft address	-----	

1. Device address=0~F.
2. Movable:Host can change device address to new address(ex:Soft,reserved address)by LISTEN R3command.

TABLE 2

DATA STRUCTURE

COMMAND	LENGTH	DEVICE ECHO	DESCRIPTION
SENDRESET	1 BYTE	NO	
FLUSH	1 BYTE	NO	
TALK R0	1 BYTE	2 BYTES	If mouse has data to report,device echoes two bytes(R0) to Host,otherwise no echo data.
TALK R1	-----	-----	No use.
TALK R2	-----	-----	No use.
TALK R3	1 BYTE	2 BYTES	Device always echoes two bytes(R3) to Host.
LISTEN R0	-----	-----	No use.
LISTEN R1	-----	-----	No use.
LISTEN R2	-----	-----	No use.
LISTEN R3	3 BYTES	NO	Host sends control status (R3) to mouse. First byte:command. Second and last bytes:R3 control register.

1. CODE:First byte reference TABLE 1.
2. LISTEN R3 command reference TABLE 4.

TABLE 3

LISTEN R3 COMMAND

CODE				DESCRIPTION
Listen R3	SRQ (B13)	Device Address	ID Number	
----	B15	~ B8	B7~B0	
3B	- - - -	- - - -	FF	Self Test.
3B	- - - -	A3 A2 A1 A0	FE	Device will change to new address(A0~A3)if no collision has been detected.
3B	- - - -	A3 A2 A1 A0	FD	Device will change to new address(A0~A3)if no collision and /Mkey is pressed.
3B	0 1 - 1	A3 A2 A1 A0	00	IF no collision has been detected,device will change to new address (A0~A3)and set (or clear)SRQ depend on B13(R3).
3B	- - - -	- - - -	01	2 counts/dot for X/Y axis.
3B	- - - -	- - - -	02	1 count/dot for X/Y axis.

1. LISTEN R3:Host transmits data to device.
 2. IF mouse Address=3 and Command=Listen R3 then command data=3B.(Ref table 1)
 3. B0 ~ B 15:R3 control register.

TABLE 4

REGISTER DESCRIPTION

REGISTER 0 (R0):mouse counter data.

B15	B14	B13	B12	B11	B10	B9	B8	B7	B6	B5	B4	B3	B2	B1	B0
\bar{M}	Y6	Y5	Y4	Y3	Y2	Y1	Y0	\bar{R}	X6	X5	X4	X3	X2	X1	X0

1. X0 ~ X6:X direction counter data.
2. Y0 ~ Y6:Y direction counter data.
3. X6(Y6)=0:Positive count when mouse move to right(down).
 X6(Y6)=1:Negative count when mouse move to left(up).
 Negative count uses 2'S complement form.
4. \bar{R} :When right key is pressed,B7 is cleared to zero,otherwise B7 status is set to one.
5. \bar{M} :When main key is pressed,B15 is cleared to zero,otherwise B15 status is set to one.

REGISTER 3 (R3):control register.

B15	B14	B13	B12	B11	B10	B9	B8	B7	B6	B5	B4	B3	B2	B1	B0
0	EE	SRQ	1	A3	A2	A1	A0	D7	D6	D5	D4	D3	D2	D1	D0

1. D0 ~ D7:Device Handler ID number. (00h ~ FFh)
2. A0 ~ A3:Device Address can be changed when host send LISTEN R3 command with ID=00,FE,FD.
3. B12:Always be“1”.
4. SRQ:Can be set or cleared when host send LISTEN R3 command with ID=00.
 SRQ=1:Device can transmit data to Host.
 SRQ=0:Device can't transmit data to Host.
5. EE(Exception Event status):No use=1.
6. B15:Always be“0”.

SIGNAL PROTOCOL

1. Attn(800us)+Sync(65us):Synchronous signal.
 Host out Attn+Sync signals to tell device when to get command code.
2. Data and command code:Data bit is discriminated by pulse code modulation.

* This specification are subject to be changed without notice.

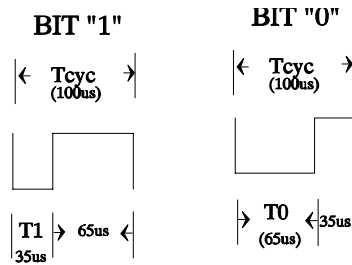

3. Tit (200us) signal: If no collision has been detected,
LISTEN command: Device waiting until Tit="0" then device start to read data in.
TALK command: Device send two bytes data after Tit.
4. Stop bit("0").
5. Start bit("1").
6. Service Request: When the device has data to report with SRQ=1, it will pull the ADB bus to be low for 300us after first stop bit of the command send by Host.

COLLISION:

1. Host send one command, but many devices respond to it.
2. Losing device:
 - a. Device detects "0" at Tit-time before device wants to send start bit.
 - b. Data line must hold "1" at Tit-time, but device detects "0" by another device send.
 - c. Device detects "0" while sending "1".
3. Losing device must give up ADB bus and data is saved.
4. Every devices must have detecting collision ability.

DYNAMIC SAMPLING RATE

When the mouse is moved, the frequency of sampling rate depends on the mouse's speed. If the mouse is still, the sampling rate is at low speed (1KHz). It can reduce system power consumption.

DPI	DOTS	SPEED(cm/sec)	SAMPLING RATE
200	0	-----	1KHz
	1	2.54	2.5KHz
	2	5.08	5KHz
	4	10.16	10KHz
320	0	-----	1KHz
	1	1.5875	2.5KHz
	2	3.175	5KHz
	4	6.35	10KHz
400	0	-----	1KHz
	1	1.27	2.5KHz
	2	2.54	5KHz
	4	5.08	10KHz
	0	-----	1KHz
560	1	0.907	2.5KHz
	2	1.814	5KHz
	4	3.632	10KHz

Formula: speed = [(dots / DPI) * 2.54] / Tb.
 EX: dot=1, DPI=200 dots/inch, Tb(Time Base)=5ms
 speed = [(1 / 200) * 2.54] / 5ms = 2.54 cm/sec

ABSOLUTE MAXIMUM RATINGS

Temperature under bias	0°C to 70°C
Storage temperature	-65°C to 150°C
Input voltage	-0.3V to +6.0V
Output voltage	-0.3V to +6.0V

DC ELECTRICAL CHARACTERISTICS

($T_A = 0^\circ\text{C} \sim 150^\circ\text{C}$, $V_{DD} = 5.0\text{V} \pm 5\%$, $V_{SS} = 0\text{V}$)

Parameter	Sym.	Min.	Typ.	Max.	Unit	Condition
Input High Voltage	V_{IH}	2.0	-	-	V	$V_{IN} = V_{DD}, V_{SS}$
Input Low Voltage	V_{IL}	-	-	0.8	V	$V_{IN} = V_{DD}, V_{SS}$
Output High Voltage	V_{OH}	2.4	-	-	V	$I_{OH} = -12.0\text{mA}$
Output Low Voltage	V_{OL}	-	-	0.4	V	$I_{OH} = 12.0\text{mA}$
Clock Input High Voltage	V_{IHx}	3.5	-	-	V	OSCI
Clock Input Low Voltage	V_{ILx}	-	-	1.5	V	OSCI
Input Leakage Current for input pin	I_{IL1}	-	-	± 10	μA	$V_{IN} = V_{DD}, V_{SS}$
Pull-high current	I_{PH}	-50	-100	-240	μA	Pull-high active, input pin at V_{SS}
Pull-down current	I_{PD}	20	50	120	μA	Pull-down active input pin at V_{DD}
Operating supply current	I_{CC}	-	-	4	mA	$\overline{\text{RESET}} = \text{HIGH}$, $F_{osc} = 3.58\text{MHz}$

AC ELECTRICAL CHARACTERISTICS

($T_A = 0^\circ\text{C} \sim 70^\circ\text{C}$, $V_{DD} = 5.0\text{V} \pm 5\%$, $V_{SS} = 0\text{V}$)

Parameter	Sym.	SPEC	Min.	Typ.	Max.	Unit
Attention signal time	Attn	$800 \pm 3\%$	550	-	2150	μs
Sync pulse time	Sync	$65 \pm 3\%$	-	-	286	μs
From first stop bit to start bit.	Tit	$200 \pm 30\%$	150	-	-	μs
Service request time	Tsrq	$300 \pm 30\%$	290	-	315	μs
Reset time	Tres	3	2.15	-	-	ms
Bit cell time	Tcyc	$100 \pm 30\%$	-	100	-	μs
Bit "0" low time	T0	$65 \pm 30\%$	-	65	-	μs
Bit "1" low time	T1	$35 \pm 30\%$	-	35	-	μs
DLED low time	DLED	-	23	-	-	μs

WAVE FORM

LISTEN COMMAND:

Host out control status to device.

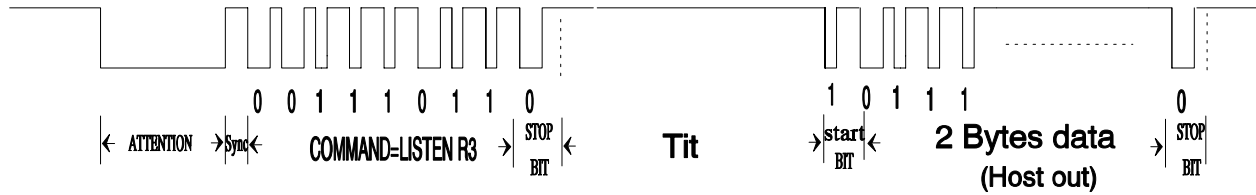

TALK COMMAND

1. Device has data to send.

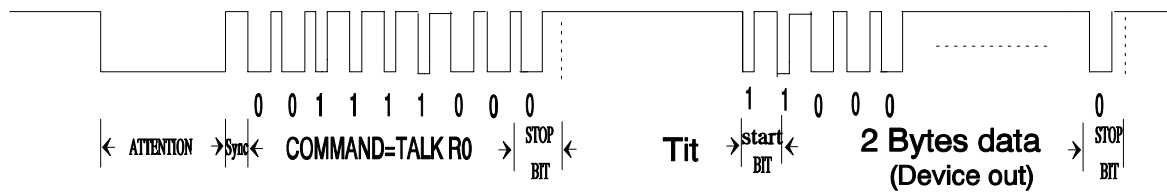

2. Host is polling device.

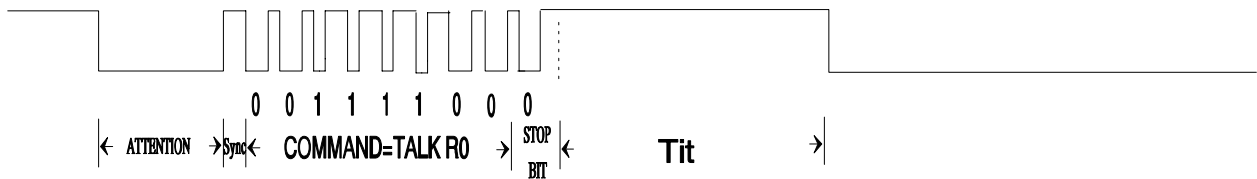

3. Service Request

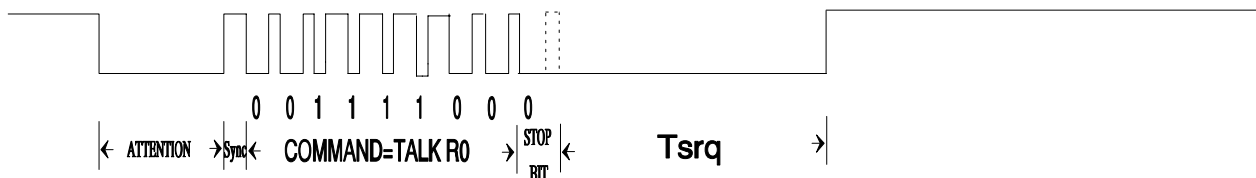

APPLICATION CIRCUIT

