

GENERAL DESCRIPTION

The EM92600/1C series are developed for 45/48 MHz of 10 channels band frequency of cordless telephone which is used in Mainland China. These devices are dual phase-locked loop frequency synthesizers contained ROM counters for receive and transmit loops with two independent phase detect circuits. A common reference oscillator and reference divider are share by the receive and transmit circuits.

Other features include a lock detect circuit for the transmit loop, illegal code default, a buffered oscillator output for mixing purposes in the system, 5KHz tone output . The EM92601C is designed for easy MPU interface. It provides the same features as the EM92600C , but accepts channel programming via a clocked, serial input instead of parallel BCD inputs. The EM92600C is selected channels via mechanical switches of parallel BCD input.

FEATURES

- Include oscillation circuit with external X-TAL (10.240 MHz).
- Unlock detector.
- 5KHz output for guard tone.
- Standby mode for power saving.
- 2.5 to 5.5V supply range.
- Baseset/Handset changeable.
- Available in 16 pin DIP or SOP.
- SERIES

Part Number	Package	Channel Selection
EM92600CP	DIP	parallel
EM92600CM	SOP	parallel
EM92601CP	DIP	serial
EM92601CM	SOP	serial

PIN ASSIGNMENTS

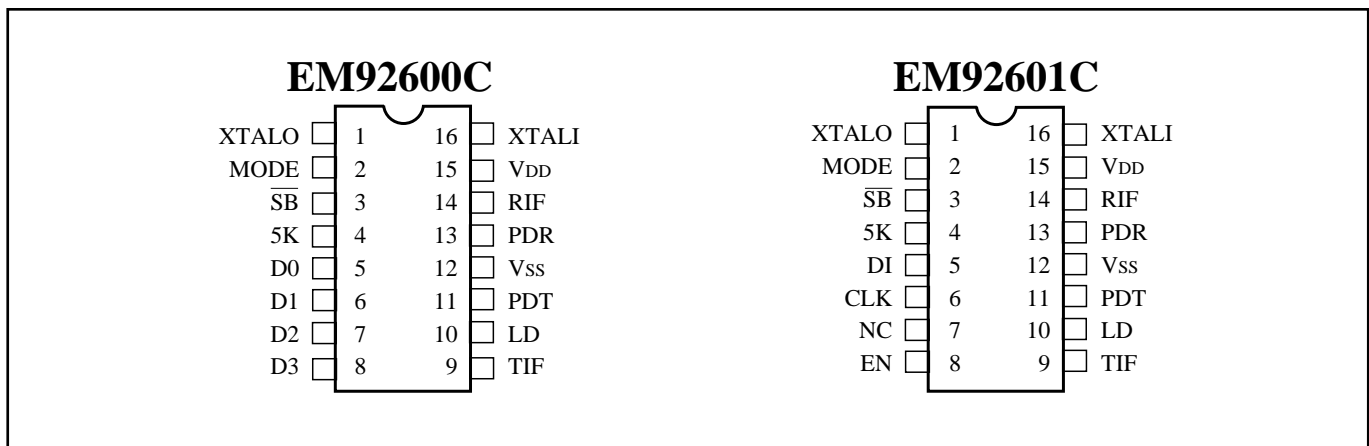

FUNCTIONAL BLOCK DIAGRAM

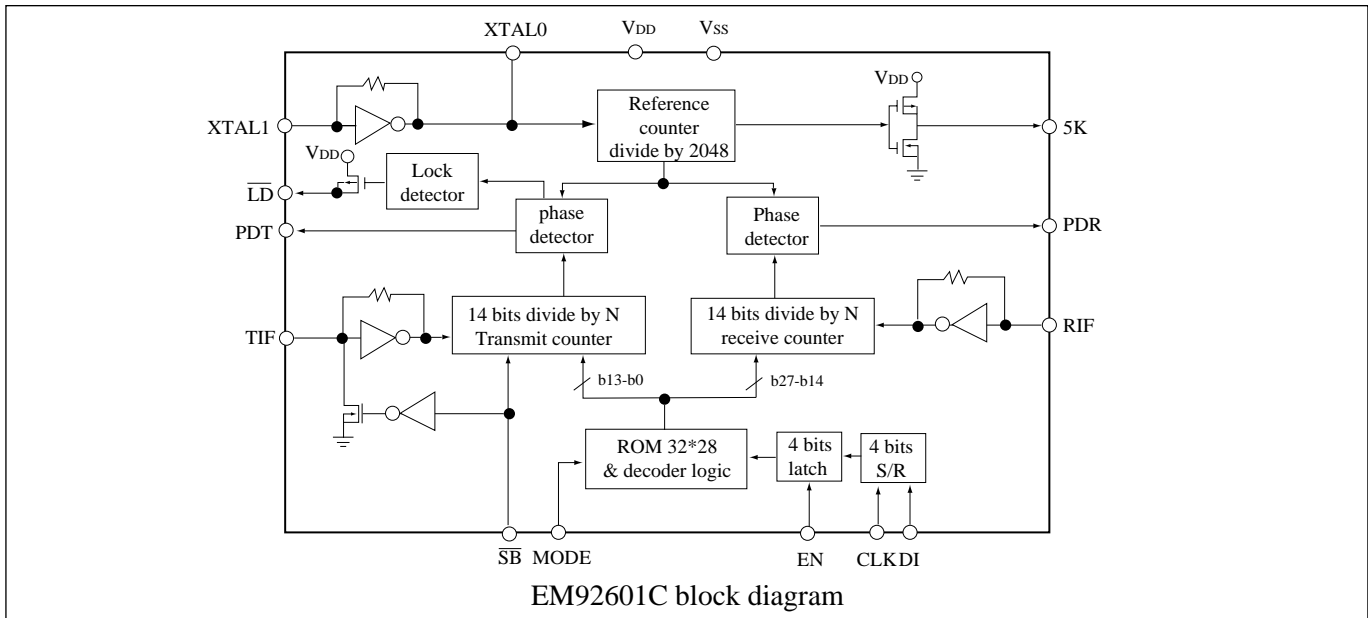
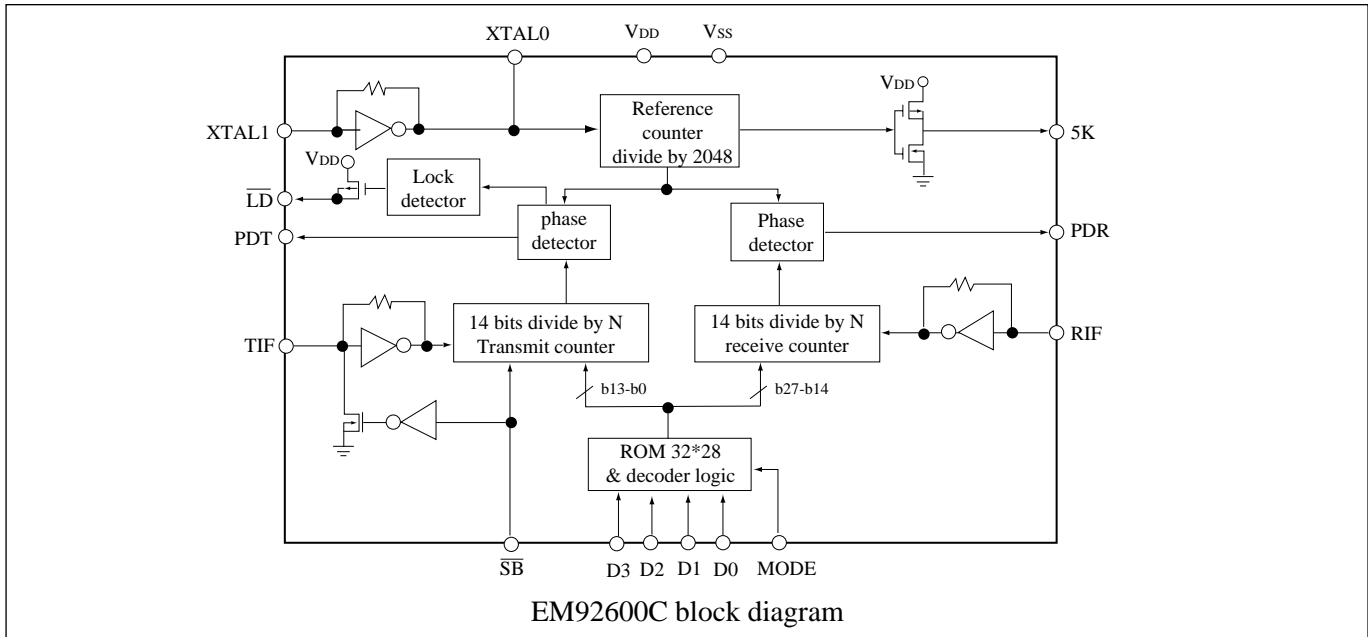

PIN DESCRIPTIONS

Symbol	Pin No.	Function
XTALO	O	This output generates reference frequency when it is connected to pin 16 with external OSC of which frequency is 10.240MHz
MODE	I	Base/remote changing. Internal pull down. V_{DD} =base, V_{SS} =remote.
\overline{SB}	I	The standby pin is used to save power when no transmit. Internal pull down. High: transmit and receive active Low: receive acts only
5K	O	The signal derived from the reference oscillator. 5KHz output.

* This specification are subject to be changed without notice.

Symbol	I/O	Function
D0	I	The channel selected pin. LSB.(internal pull down)
D1	I	The channel selected pin. (internal pull down)
D2	I	The channel selected pin. (internal pull down)
D3	I	The channel selected pin. MSB.(internal pull down)
D _i	I	The serial input data pin.
CLK	I	Clock input. Each low to high transition of the clock shifts one bit of data into the on-chip shift register.
NC	-	Not connect.
EN	I	The enable pin controls the data transfer from the shift register to the 4-bit latch. A low to high transition latches the data.
TIF	I	Input to programmable divider of Tx. AC coupling with VCO. Min input voltage is 200mVp-p.
$\overline{\text{LD}}$	O	Unlock detector output. V _{DD} level: unlock.
PDT	O	Phase detector output for Tx. PDT detects the phase error from Tx PLL and its output is connected to external low pass filter.
V _{SS}	-	Ground.
PDR	O	Phase detector output for Rx. PDR detects the phase error from Rx PLL and its output is connected to external low pass filter.
RIF	I	Input of programmable divider for Rx.AC coupling with VCO. Min input voltage is 200mVp-p.
V _{DD}	-	Power supply.
XTAL1	I	To connect crystal (10.240MHz) and capacitor.

ABSOLUTE MAXIMUM RATINGS

Symbol	Rating	Value	Unit
V _{DD}	DC supply voltage	-0.5 to +6	V
V _{IN}	Input voltage	-0.5 to V _{DD} +0.5	V
I _{IN} , I _{OUT}	DC current drain per pin	10.0	mA
I _{DD} , I _{SS}	DC current drain V _{DD} or V _{SS} pins	30.0	mA
T _A	Operating temperature range	-30 to +75	°C
T _{STG}	Storage temperature range	-65 to +150	°C

DC ELECTRICAL CHARACTERISTICS

($T_A = 25^\circ\text{C}$ unless otherwise noted)

Parameter	Sym.	Min.	Typ.	Max.	Unit	Condition
Operating voltage	V_{DD}	2.5	-	5.5	V	
Input voltage	V_{IL} V_{IH}	2.2	-	0.8	V	$V_{DD}=3\text{V}$
Output voltage	V_{OL} V_{OH}	2.95	-	0.05	V	$V_{DD}=3\text{V}$
Input low current	I_{IL}	-36 -0.06	- -		μA	$v_{IL}=0$ pin 16,14,9 pin 2~8
Input high current	I_{IH}		- -	36 120	μA	$v_{IH}=V_{DD}-0.5\text{V}$ pin 16,14,9 pin 2~8
Output current	I_{OH} I_{OL}	-0.2 0.2	- -		mA	$V_{OH}=2.6\text{V}$ $V_{OL}=0.4\text{V}$
Standby current	I_{DS}		-	1.5	mA	$V_{DD}=3\text{V}$, note1
Operating current (0.2Vp-p input at RIF,TIF)	I_{DO}		-	3.0	mA	$V_{DD}=3\text{V}$, note2
3-state leakage current	I_{OZ}		-	± 1	μA	$V_{DD}=5\text{V}$

Note 1: XTALin: 10.24MHz ; MODE: V_{DD} ; $\overline{\text{SB}}$: V_{SS} ; TIF=20MHz(200 mVp-p); RIF=40MHz(200 mVp-p); others are open.

Note 2: XTALin: 10.24MHz ; MODE: V_{DD} ; $\overline{\text{SB}}$: V_{DD} ; TIF=20MHz(200 mVp-p); RIF=40MHz(200 mVp-p); others are open.

AC ELECTRICAL CHARACTERISTICS

Parameter	Sym.	Min.	Typ.	Max.	Unit	Condition
Output rise time	T_R			200	nS	$V_{DD}=3\text{V}$
Output fall time	T_F			200	nS	$V_{DD}=3\text{V}$
Input rise and fall time	T_R T_F			5	μS	XTAL1 $V_{DD}=3\text{V}$
Maximum frequency input =sine wave 0.2Vp-p OSC in	F_{MAX}			12 50 50	MHz	XTAL1 RIF ($V_{DD}=3\text{V}$) TIF
Setup time data to clock Enable to clock	T_{SU}	100 200			nS	EM92601C only
Hold time clock to data	T_H	80			nS	EM92601C only
Recovery time Enable to clock	T_{REC}	80			nS	EM92601C only
Input pulse width clock and Enable	T_W	80			nS	EM92601C only

TIMING DIAGRAM

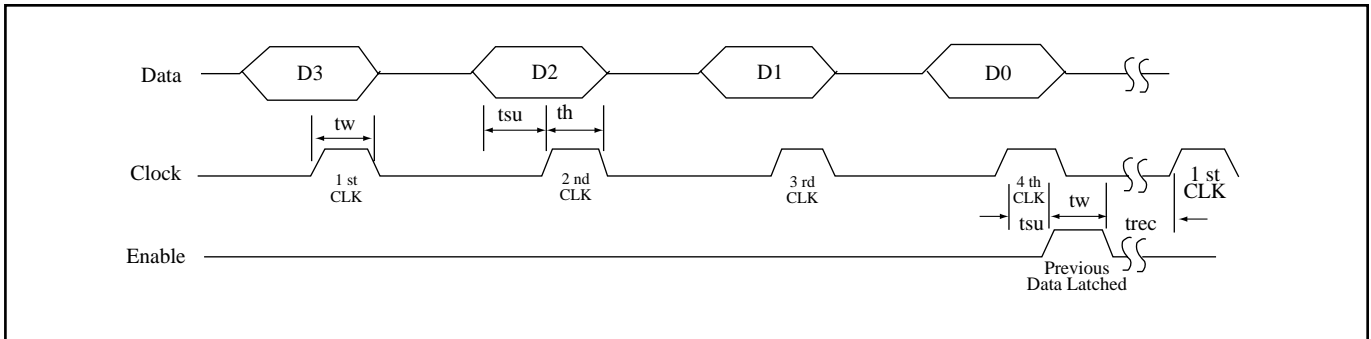

EM92601C Timing

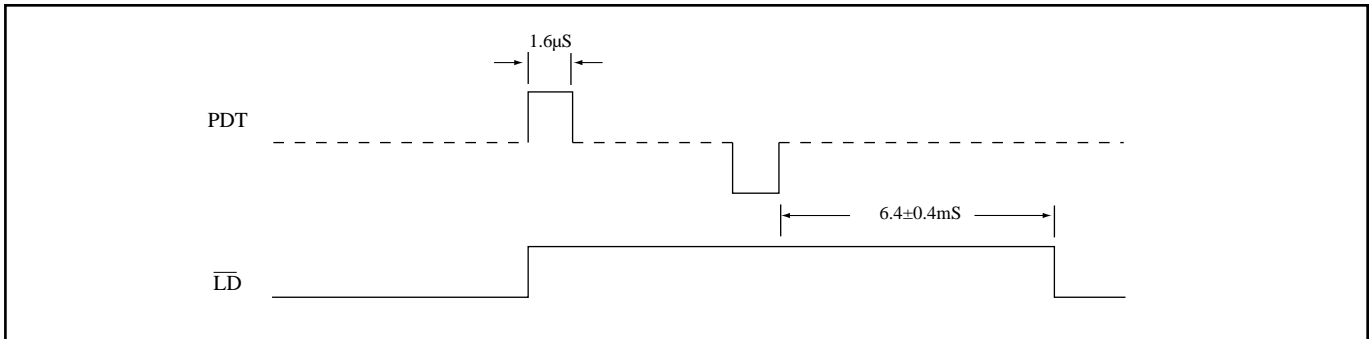

Unlock Timing

APPLICATION CIRCUIT

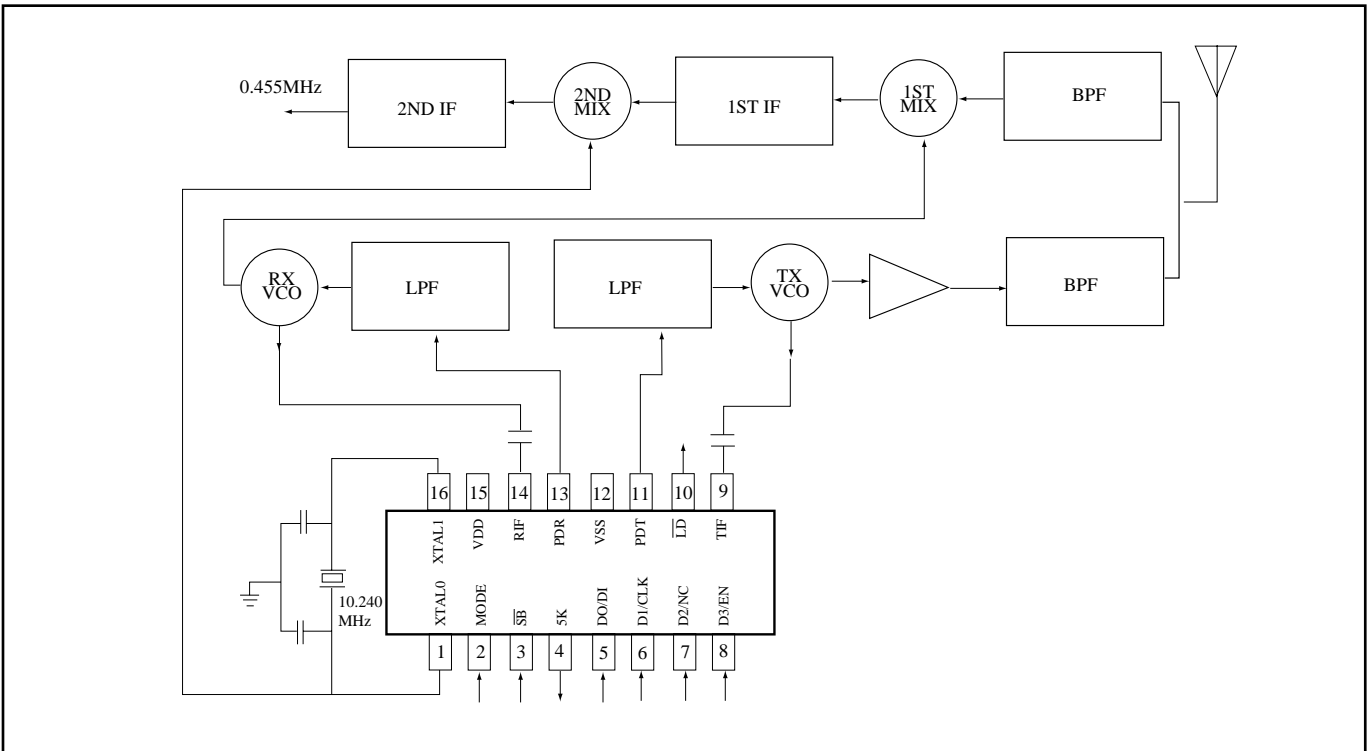



DIVIDE RATIO AND VCO FREQUENCIES

Base (MODE=1)	Input				CH	Rx (Fref=5KHz)			Tx=(Fref=5KHz)		
	D3	D2	D1	D0		FRx (MHz)	FVCO(MHz)	N	FTx(MHz)	FVCO(MHz)	N
	0	0	0	1	1	48.250	37.555	7511	45.250	45.250	9050
	0	0	1	0	2	48.275	37.580	7516	45.275	45.275	9055
	0	0	1	1	3	48.300	37.605	7521	45.300	45.300	9060
	0	1	0	0	4	48.325	37.630	7526	45.325	45.325	9065
	0	1	0	1	5	48.350	37.655	7531	45.350	45.350	9070
	0	1	1	0	6	48.375	37.680	7536	45.375	45.375	9075
	0	1	1	1	7	48.400	37.705	7541	45.400	45.400	9080
	1	0	0	0	8	48.425	37.730	7546	45.425	45.425	9085
	1	0	0	1	9	48.450	37.755	7551	45.450	45.450	9090
	1	0	1	0	10	48.475	37.780	7556	45.475	45.475	9095
	1	0	1	1		48.475	37.780	7556	45.475	45.475	9095
	1	1	0	0		48.475	37.780	7556	45.475	45.475	9095
	1	1	0	1		48.475	37.780	7556	45.475	45.475	9095
	1	1	1	0		48.475	37.780	7556	45.475	45.475	9095
	1	1	1	1		48.475	37.780	7556	45.475	45.475	9095
	0	0	0	0		48.475	37.780	7556	45.475	45.475	9095

REMOTE (MODE=0)	Input				CH	Rx (Fref=5KHz)			Tx=(Fref=5KHz)		
	D3	D2	D1	D0		FRx (MHz)	FVCO(MHz)	N	FTx(MHz)	FVCO(MHz)	N
	0	0	0	1	1	45.250	34.555	6911	48.250	48.250	9650
	0	0	1	0	2	45.275	34.580	6916	48.275	48.275	9655
	0	0	1	1	3	45.300	34.605	6921	48.300	48.300	9660
	0	1	0	0	4	45.325	34.630	6926	48.325	48.325	9665
	0	1	0	1	5	45.350	34.655	6931	48.350	48.350	9670
	0	1	1	0	6	45.375	34.680	6936	48.375	48.375	9675
	0	1	1	1	7	45.400	34.706	6941	48.400	48.400	9680
	1	0	0	0	8	45.425	34.730	6946	48.425	48.425	9685
	1	0	0	1	9	45.450	34.755	6951	48.450	48.450	9690
	1	0	1	0	10	45.475	34.780	6956	48.475	48.475	9695
	1	0	1	1		45.475	34.780	6956	48.475	48.475	9695
	1	1	0	0		45.475	34.780	6956	48.475	48.475	9695
	1	1	0	1		45.475	34.780	6956	48.475	48.475	9695
	1	1	1	0		45.475	34.780	6956	48.475	48.475	9695
	1	1	1	1		45.475	34.780	6956	48.475	48.475	9695
	0	0	0	0		45.475	34.780	6956	48.475	48.475	9695