

## EPC2014C – Enhancement Mode Power Transistor

 $V_{DS}$ , 40 V $R_{DS(on)}$ , 16 m $\Omega$  $I_D$ , 10 A

Gallium Nitride's exceptionally high electron mobility and low temperature coefficient allows very low  $R_{DS(on)}$ , while its lateral device structure and majority carrier diode provide exceptionally low  $Q_G$  and zero  $Q_{RR}$ . The end result is a device that can handle tasks where very high switching frequency, and low on-time are beneficial as well as those where on-state losses dominate.

Maximum Ratings			
PARAMETER		VALUE	UNIT
$V_{DS}$	Drain-to-Source Voltage (Continuous)	40	V
	Drain-to-Source Voltage (up to 10,000 5 ms pulses at 150°C)	48	
$I_D$	Continuous ( $T_A = 25^\circ\text{C}$ , $R_{\theta JA} = 43^\circ\text{C/W}$ )	10	A
	Pulsed ( $25^\circ\text{C}$ , $T_{PULSE} = 300 \mu\text{s}$ )	60	
$V_{GS}$	Gate-to-Source Voltage	6	V
	Gate-to-Source Voltage	-4	
$T_J$	Operating Temperature	-40 to 150	$^\circ\text{C}$
$T_{STG}$	Storage Temperature	-40 to 150	

Thermal Characteristics			
PARAMETER		TYP	UNIT
$R_{\theta JC}$	Thermal Resistance, Junction-to-Case	3.6	$^\circ\text{C/W}$
$R_{\theta JB}$	Thermal Resistance, Junction-to-Board	9.3	
$R_{\theta JA}$	Thermal Resistance, Junction-to-Ambient (Note 1)	80	

Note 1:  $R_{\theta JA}$  is determined with the device mounted on one square inch of copper pad, single layer 2 oz copper on FR4 board. See [https://epc-co.com/epc/documents/product-training/Appnote\\_Thermal\\_Performance\\_of\\_eGaN\\_FETs.pdf](https://epc-co.com/epc/documents/product-training/Appnote_Thermal_Performance_of_eGaN_FETs.pdf) for details.

Static Characteristics ( $T_J = 25^\circ\text{C}$ unless otherwise stated)						
PARAMETER		TEST CONDITIONS	MIN	TYP	MAX	UNIT
$BV_{DSS}$	Drain-to-Source Voltage	$V_{GS} = 0 \text{ V}$ , $I_D = 125 \mu\text{A}$	40			V
$I_{DSS}$	Drain-Source Leakage	$V_{GS} = 0 \text{ V}$ , $V_{DS} = 32 \text{ V}$		50	100	$\mu\text{A}$
$I_{GSS}$	Gate-to-Source Forward Leakage	$V_{GS} = 5 \text{ V}$		0.4	2	mA
	Gate-to-Source Reverse Leakage	$V_{GS} = -4 \text{ V}$		50	100	$\mu\text{A}$
$V_{GS(TH)}$	Gate Threshold Voltage	$V_{DS} = V_{GS}$ , $I_D = 2 \text{ mA}$	0.8	1.4	2.5	V
$R_{DS(on)}$	Drain-Source On Resistance	$V_{GS} = 5 \text{ V}$ , $I_D = 10 \text{ A}$		12	16	m $\Omega$
$V_{SD}$	Source-Drain Forward Voltage	$I_S = 0.5 \text{ A}$ , $V_{GS} = 0 \text{ V}$		1.8		V

All measurements were done with substrate connected to source.



EPC2014C eGaN® FETs are supplied only in passivated die form with solder bumps

**Applications**

- High Frequency DC-DC conversion
- Class-D Audio
- Wireless Power Transfer
- Lidar

**Benefits**

- Ultra High Efficiency
- Ultra Low  $R_{DS(on)}$
- Ultra Low  $Q_G$
- Ultra Small Footprint

Dynamic Characteristics ( $T_j = 25^\circ\text{C}$  unless otherwise stated)

PARAMETER		TEST CONDITIONS	MIN	TYP	MAX	UNIT
$C_{ISS}$	Input Capacitance	$V_{DS} = 20\text{ V}, V_{GS} = 0\text{ V}$		220	300	pF
$C_{RSS}$	Reverse Transfer Capacitance			6.5	9.5	
$C_{OSS}$	Output Capacitance			150	210	
$R_G$	Gate Resistance			0.4		$\Omega$
$Q_G$	Total Gate Charge	$V_{DS} = 20\text{ V}, V_{GS} = 5\text{ V}, I_D = 10\text{ A}$		2	2.5	nC
$Q_{GS}$	Gate-to-Source Charge	$V_{DS} = 20\text{ V}, I_D = 10\text{ A}$		0.7		
$Q_{GD}$	Gate-to-Drain Charge			0.3	0.5	
$Q_{G(TH)}$	Gate Charge at Threshold			0.5		
$Q_{OSS}$	Output Charge	$V_{DS} = 20\text{ V}, V_{GS} = 0\text{ V}$		4	6	
$Q_{RR}$	Source-Drain Recovery Charge			0		

All measurements were done with substrate connected to source.

Note 2:  $C_{OSS(ER)}$  is a fixed capacitance that gives the same stored energy as  $C_{OSS}$  while  $V_{DS}$  is rising from 0 to 50%  $BV_{DSS}$ .

Note 3:  $C_{OSS(TR)}$  is a fixed capacitance that gives the same charging time as  $C_{OSS}$  while  $V_{DS}$  is rising from 0 to 50%  $BV_{DSS}$ .

Figure 1: Typical Output Characteristics

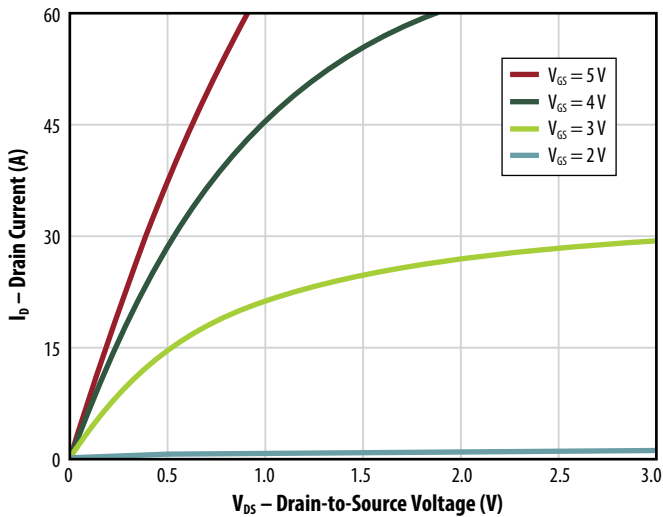

Figure 2: Transfer Characteristics

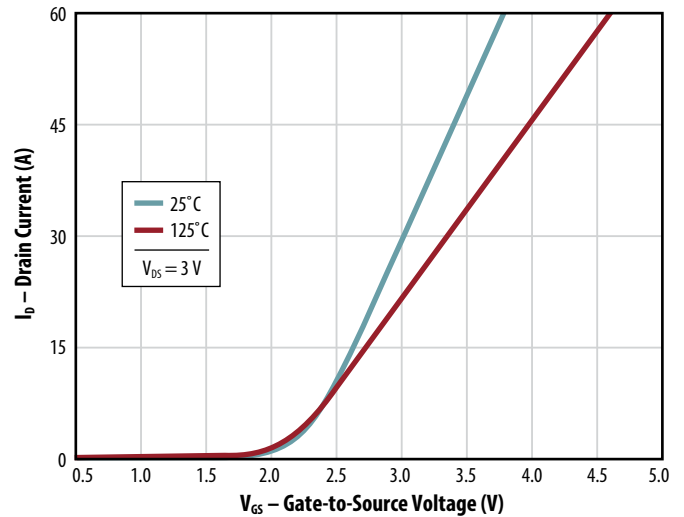

Figure 3:  $R_{DS(on)}$  vs.  $V_{GS}$  for Various Drain Currents

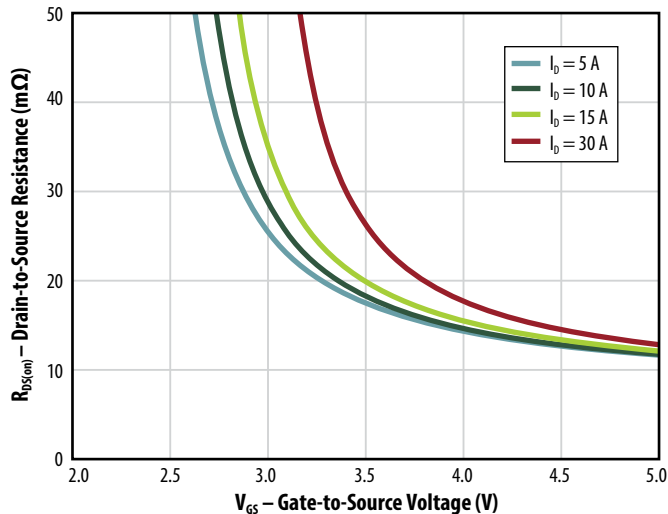

Figure 4:  $R_{DS(on)}$  vs.  $V_{GS}$  for Various Temperatures

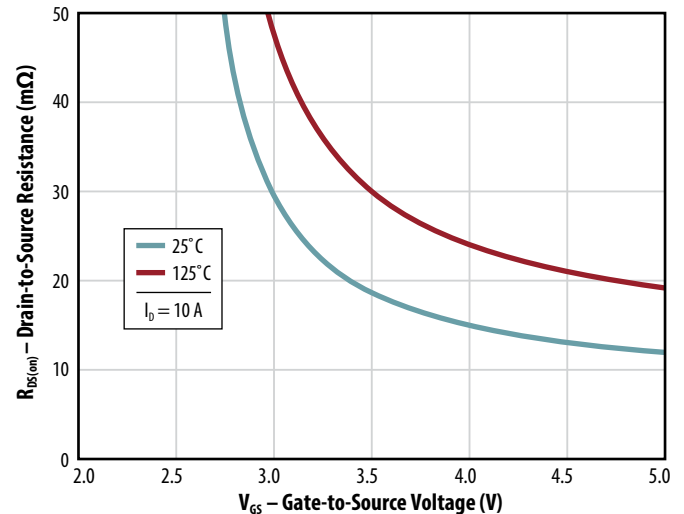

Figure 5a: Capacitance

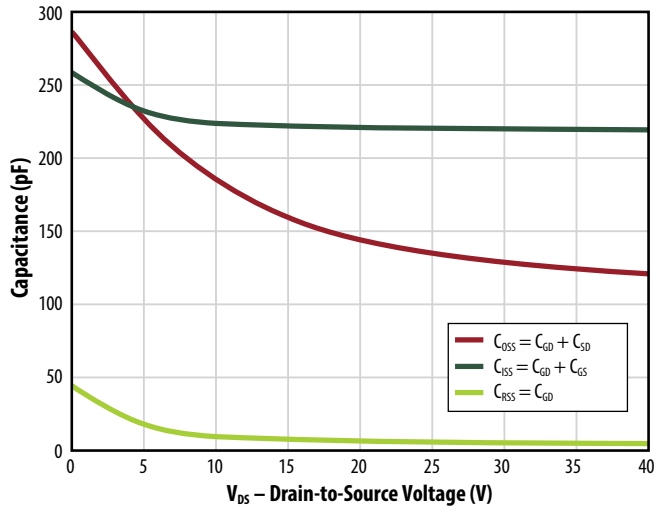

Figure 5b: Capacitance

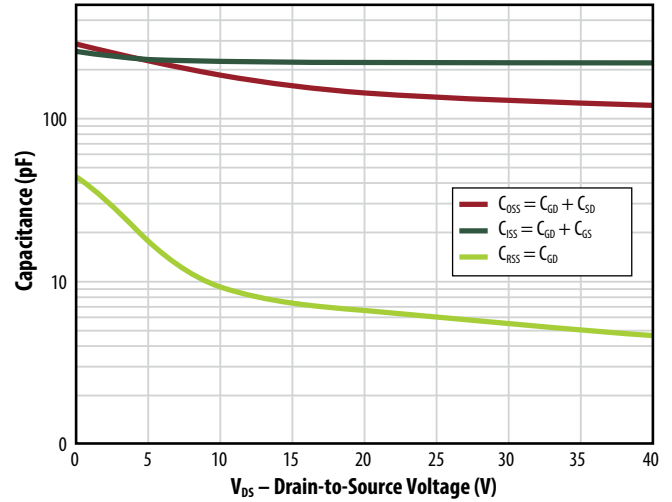

Figure 6: Gate Charge

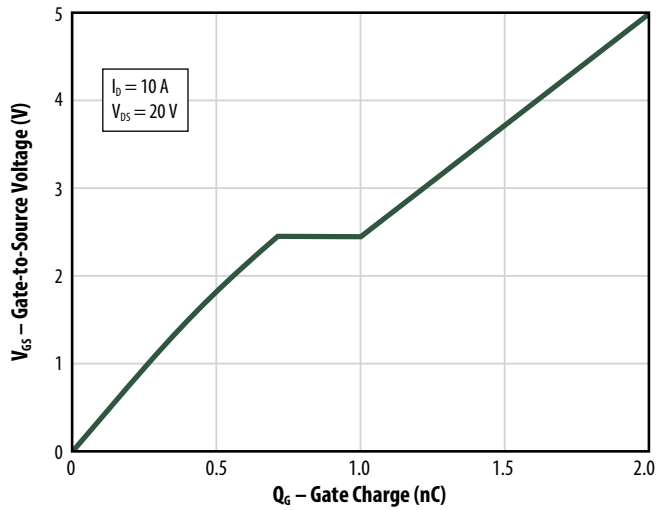

Figure 7: Reverse Drain-Source Characteristics

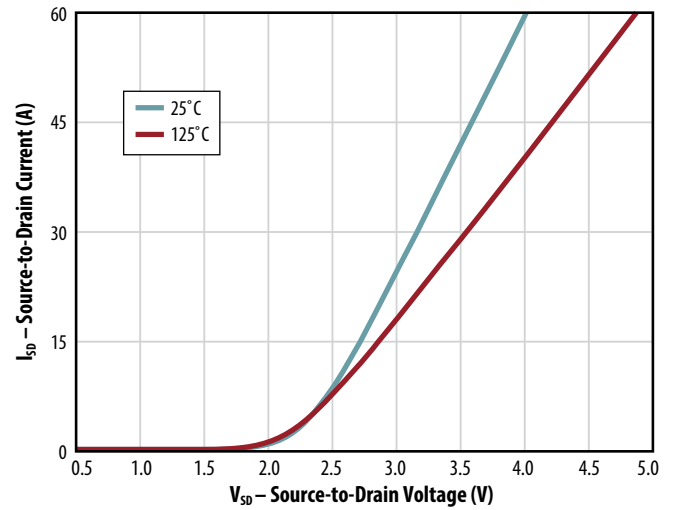

Figure 8: Normalized On Resistance vs. Temperature

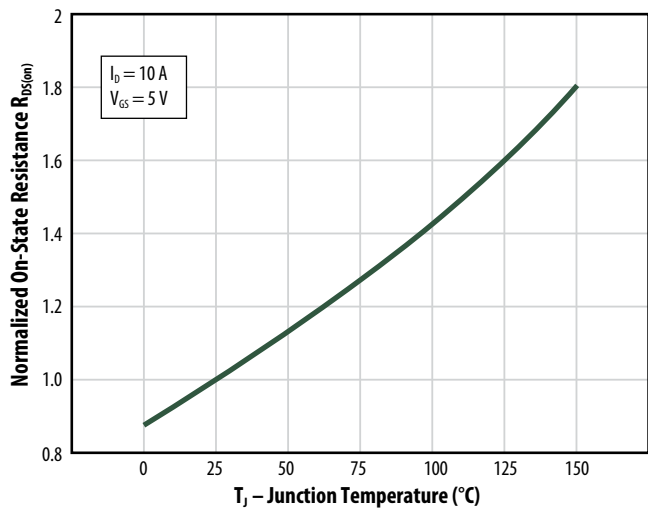
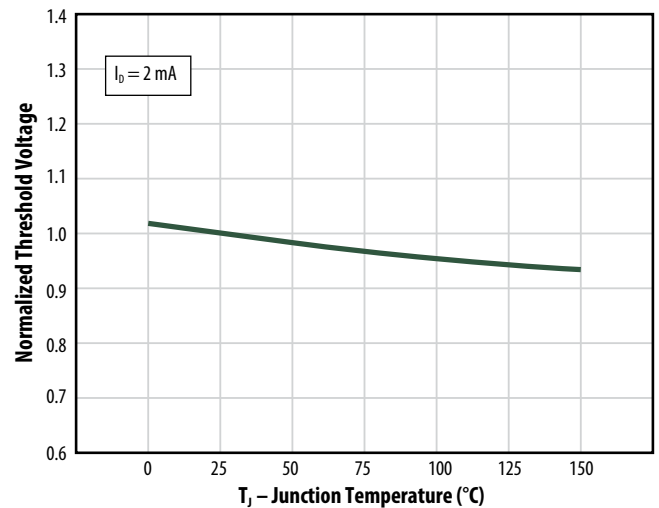

Figure 9: Normalized Threshold Voltage vs. Temperature



All measurements were done with substrate shorted to source.

Figure 10: Gate Current

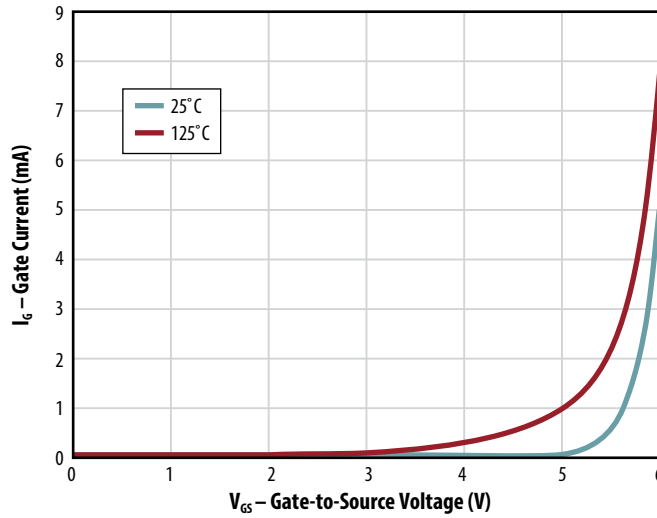

Figure 11: Transient Thermal Response Curves

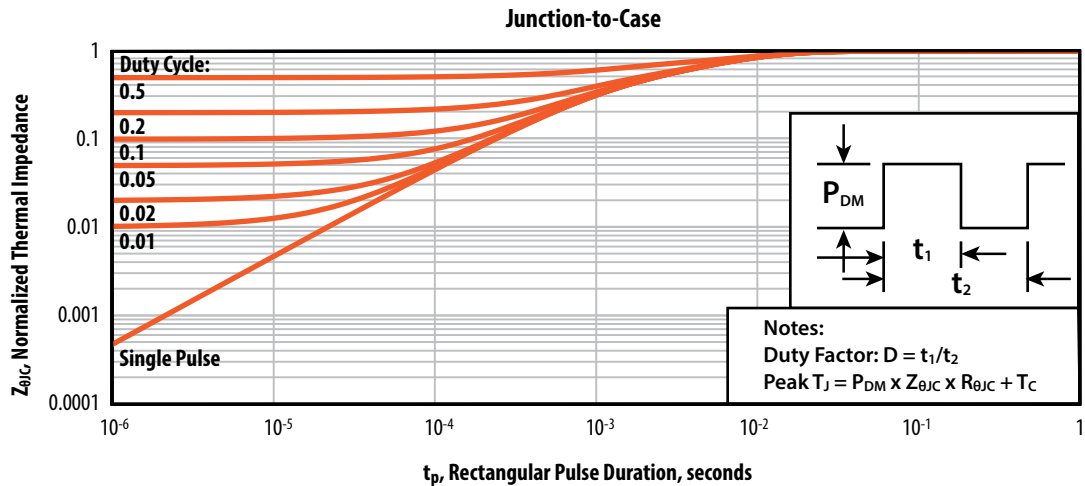
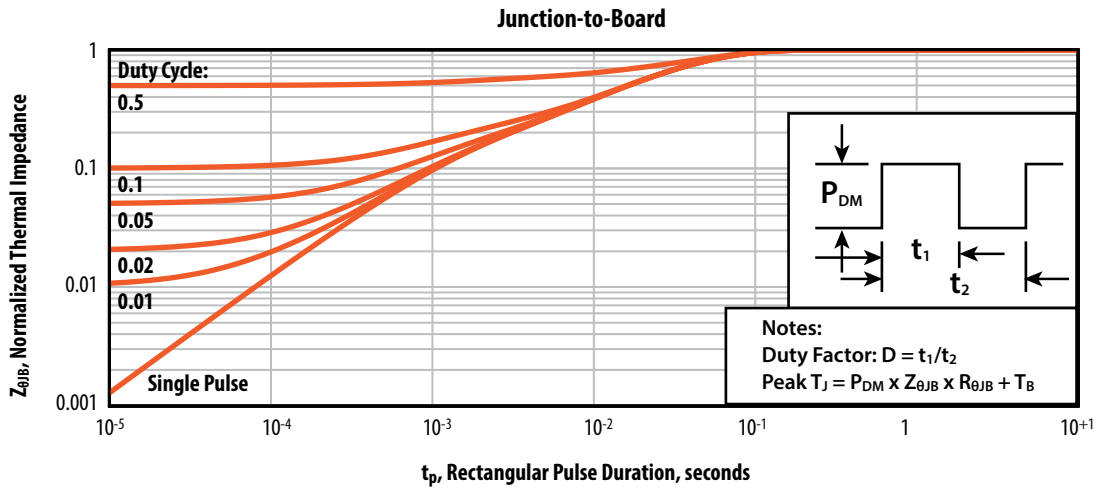
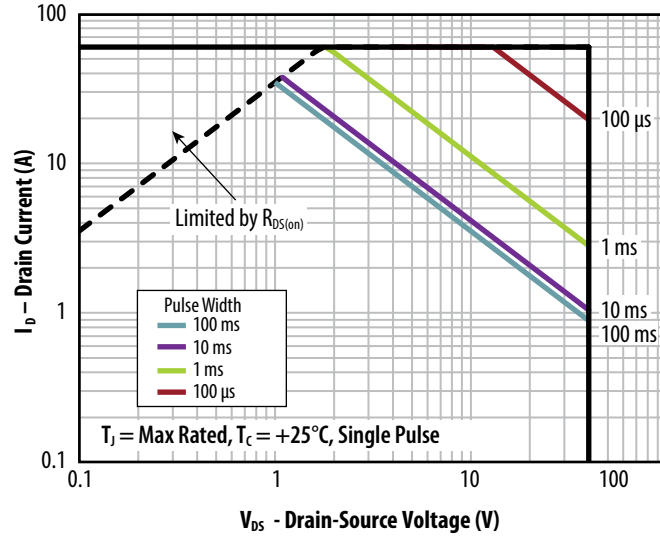
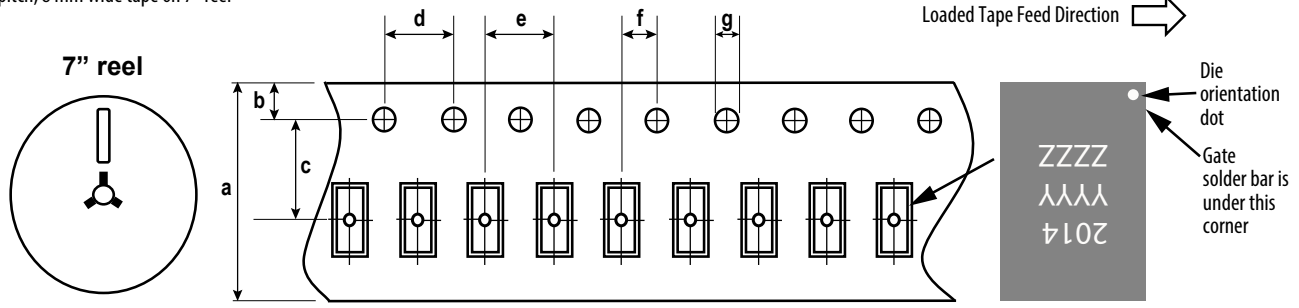

Figure 12: Safe Operating Area



**TAPE AND REEL CONFIGURATION**

4 mm pitch, 8 mm wide tape on 7" reel



Dimension (mm)	EPC2014C (note 1)		
	target	min	max
a	8.00	7.90	8.30
b	1.75	1.65	1.85
c (note 2)	3.50	3.45	3.55
d	4.00	3.90	4.10
e	4.00	3.90	4.10
f (note 2)	2.00	1.95	2.05
g	1.5	1.5	1.6

Die is placed into pocket solder bar side down (face side down)

Note 1: MSL 1 (moisture sensitivity level 1) classified according to IPC/JEDEC industry standard.  
 Note 2: Pocket position is relative to the sprocket hole measured as true position of the pocket, not the pocket hole.

**DIE MARKINGS**

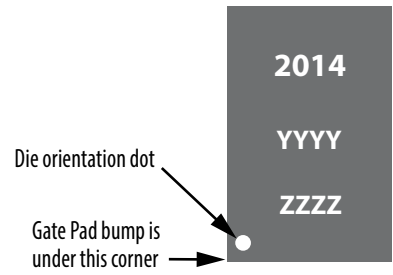

Part Number	Laser Markings		
	Part # Marking Line 1	Lot_Date Code Marking line 2	Lot_Date Code Marking Line 3
EPC2014C	2014	YYYY	ZZZZ

**DIE OUTLINE**

Solder Bar View

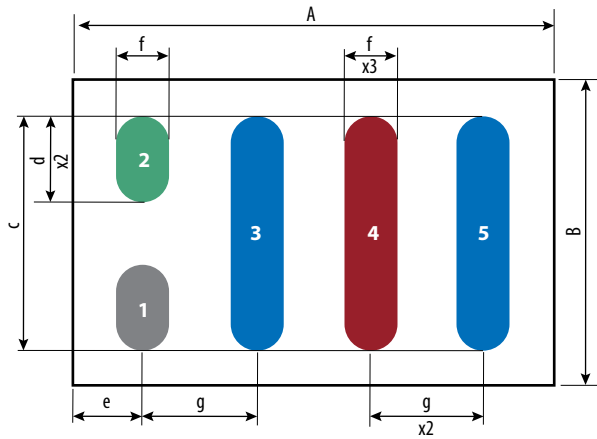

Side View

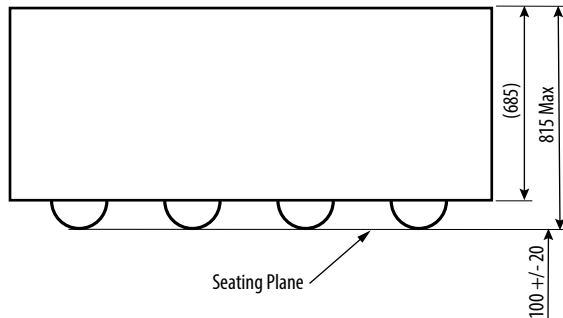

DIM	MICROMETERS		
	MIN	Nominal	MAX
A	1672	1702	1732
B	1057	1087	1117
c	829	834	839
d	311	316	321
e	235	250	265
f	195	200	205
g	400	400	400

Pad no. 1 is Gate;

Pad no. 2 is Substrate;\*

Pads no. 3 and 5 are Drain;

Pad no. 4 is Source

\*Substrate pin should be connected to Source

**RECOMMENDED LAND PATTERN**

(measurements in  $\mu\text{m}$ )

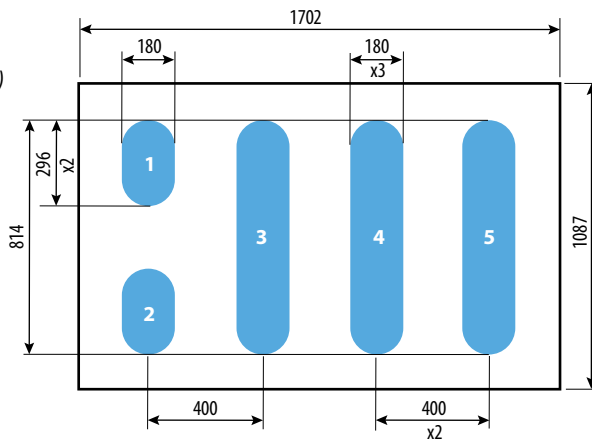

The land pattern is solder mask defined

Solder mask is 10  $\mu\text{m}$  smaller per side than bump

Pad no. 1 is Gate;

Pad no. 2 is Substrate;\*

Pads no. 3 and 5 are Drain;

Pad no. 4 is Source

\*Substrate pin should be connected to Source

**RECOMMENDED STENCIL DRAWING**

(units in  $\mu\text{m}$ )

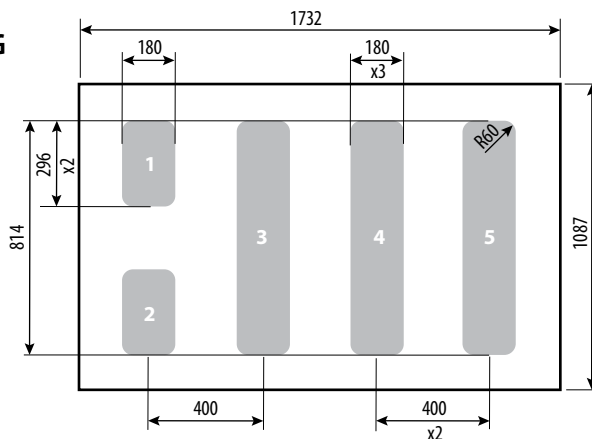

Recommended stencil should be 4 mil (100  $\mu\text{m}$ )

thick, must be laser cut, opening per drawing.

The corner has a radius of R60.

Intended for use with SAC305 Type 3 solder,

reference 88.5% metals content.

Additional assembly resources available at

<https://www.epc-co.com/epc/DesignSupport/AssemblyBasics.aspx>

Efficient Power Conversion Corporation (EPC) reserves the right to make changes without further notice to any products herein to improve reliability, function or design. EPC does not assume any liability arising out of the application or use of any product or circuit described herein; neither does it convey any license under its patent rights, nor the rights of others.

eGaN® is a registered trademark of Efficient Power Conversion Corporation.

EPC Patent Listing: [epc-co.com/epc/AboutEPC/Patents.aspx](http://epc-co.com/epc/AboutEPC/Patents.aspx)

Information subject to change without notice.

Revised August, 2019