

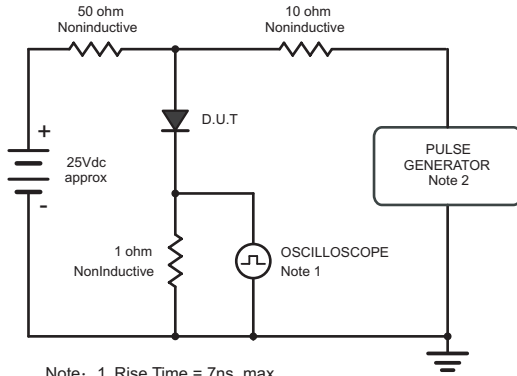

RATINGS AND CHARACTERISTIC CURVES

Fig.1 Reverse Recovery Time Characteristic And Test Circuit Diagram



Note: 1. Rise Time = 7ns, max.
Input Impedance = 1megohm, 22pF.
2. Rise Time = 10ns, max.
Source Impedance = 50 ohms.

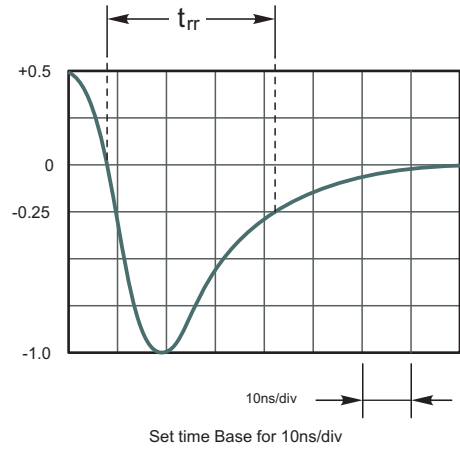

Fig.2 Maximum Average Forward Current Rating

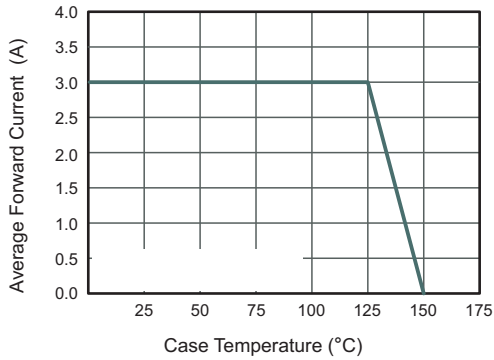

Fig.3 Typical Reverse Characteristics

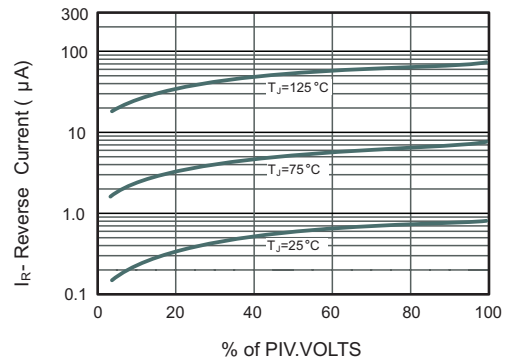

Fig.4 Typical Forward Characteristics

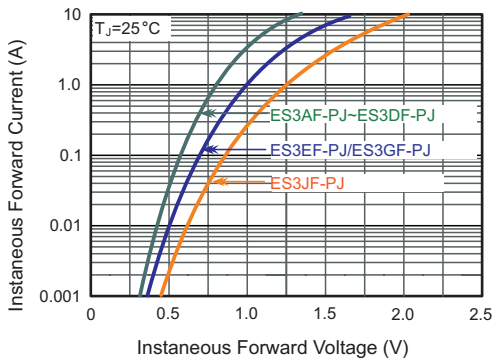

Fig.5 Typical Junction Capacitance

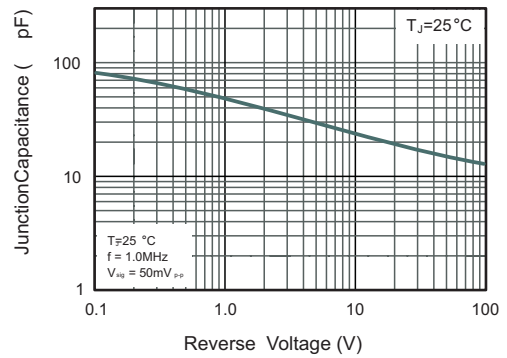
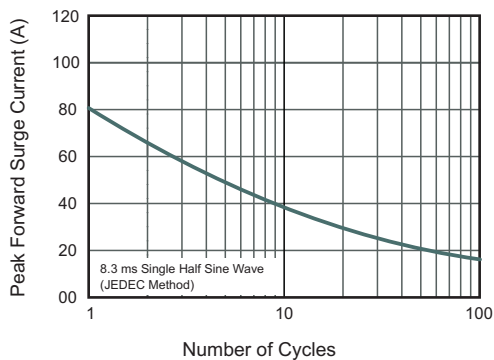

Fig.6 Maximum Non-Repetitive Peak Forward Surge Current





PACKAGE OUTLINE

SMAF

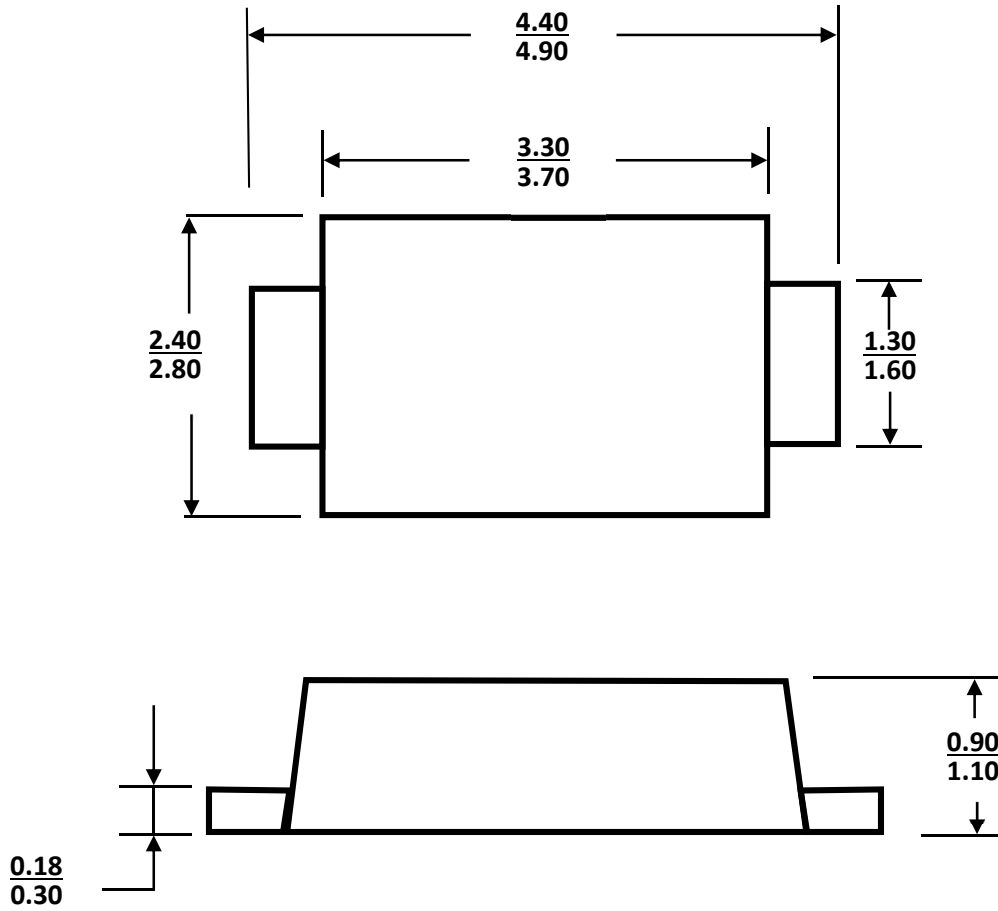

Dimensions in millimeters

ORDERING INFORMATION

Device	Package	Shipping
ES3AF-PJ thru ES3JF-PJ	SMAF	3,000/Tape & Reel (7 inches)
		10,000/ Tape & Reel (13 inches)