

Pb Free Plating Product

ES5A thru ES5J



5.0 Ampere Surface Mount Type Super Fast Recovery Rectifier Diodes

FEATURE

- ◆ Glass passivated chip junction
- ◆ The plastic package carries Underwriters Laboratory Flammability Classification 94V-0
- ◆ For surface mounted applications
- ◆ Low reverse leakage
- ◆ Built-in strain relief, ideal for automated placement
- ◆ High forward surge current capability
- ◆ High temperature soldering guaranteed: 250°C/10 seconds at terminals

MECHANICAL DATA

Case: SMC/DO-214AB Package
Terminals: Solder plated, solderable per MIL-STD-750, Method 2026
Polarity: Color band denotes cathode band
Mounting Position: Any
Weight: 0.22 gram approximately

APPLICATION

- ◆ LED SMPS/Industrial power supply
- ◆ HID ballast stabilizer
- ◆ Telecommunication SMPS/LED street lamp

OUTLINE

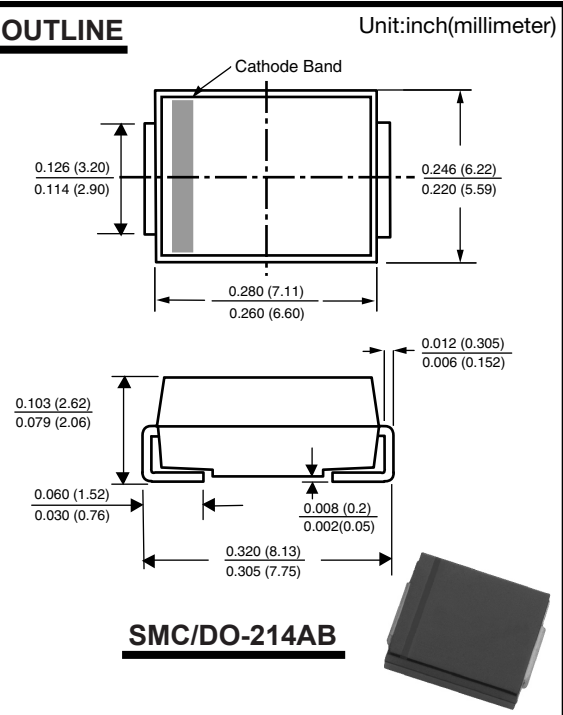

MAXIMUM RATINGS AND ELECTRICAL CHARACTERISTICS

Ratings at 25°C ambient temperature unless otherwise specified.

Single phase half-wave 60Hz, resistive or inductive load, for capacitive load current derate by 20%.

	SYMBOLS	ES5A	ES5B	ES5C	ES5D	ES5E	ES5G	ES5J	UNITS
Maximum repetitive peak reverse voltage	V_{RRM}	50	100	150	200	300	400	600	VOLTS
Maximum RMS voltage	V_{RMS}	35	70	105	140	210	280	420	VOLTS
Maximum DC blocking voltage	V_{DC}	50	100	150	200	300	400	600	VOLTS
Maximum average forward rectified current at $T_L=75^\circ\text{C}$	$I_{(AV)}$	5.0							Amps
Peak forward surge current 8.3ms single half sine-wave superimposed on rated load (JEDEC Method)	I_{FSM}	150.0							Amps
Maximum instantaneous forward voltage at 5.0A	V_F	0.95			1.3		1.7		Volts
Maximum DC reverse current $T_A=25^\circ\text{C}$ at rated DC blocking voltage $T_A=100^\circ\text{C}$	I_R	10.0 300.0							μA
Maximum reverse recovery time (NOTE 1)	t_{rr}	35							ns
Typical junction capacitance (NOTE 2)	C_J	58.0							pF
Typical thermal resistance	$R_{\theta JA}$	47.0							$^\circ\text{C/W}$
Operating junction and storage temperature range	T_J, T_{STG}	-65 to +150							$^\circ\text{C}$

Note: 1. Reverse recovery condition $I_F=0.5\text{A}, I_R=1.0\text{A}, I_{rr}=0.25\text{A}$

2. Measured at 1MHz and applied reverse voltage of 4.0V D.C.

RATINGS AND CHARACTERISTIC CURVES ES5A thru ES5J

AVERAGE FORWARD RECTIFIED CURRENT, AMPERES

FIG. 1- FORWARD CURRENT DERATING CURVE

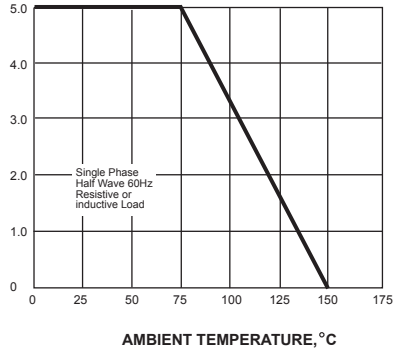

PEAK FORWARD SURGE CURRENT, AMPERES

FIG. 2-MAXIMUM NON-REPETITIVE PEAK FORWARD SURGE CURRENT

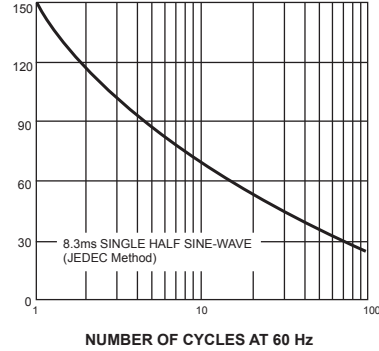

FIG. 3-TYPICAL INSTANTANEOUS FORWARD CHARACTERISTICS

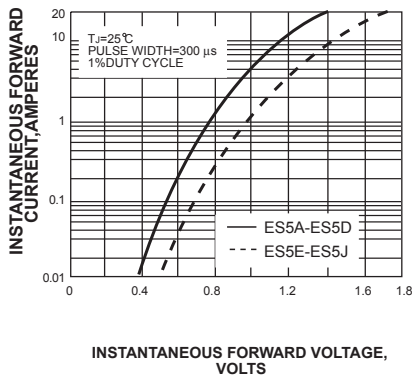

FIG. 4-TYPICAL REVERSE CHARACTERISTICS

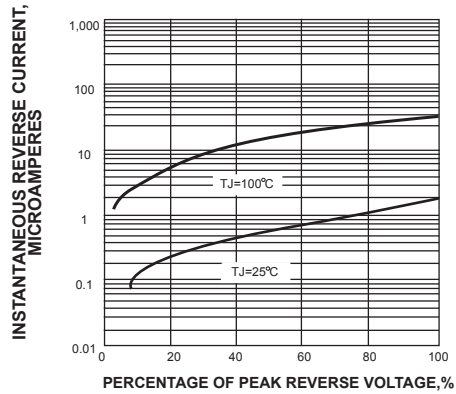
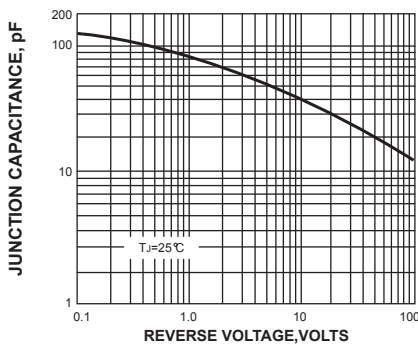

FIG. 5-TYPICAL JUNCTION CAPACITANCE



TRANSIENT THERMAL IMPEDANCE, °C/W

FIG. 6-TYPICAL TRANSIENT THERMAL IMPEDANCE

