

## ESD3V0J4

### Description

ESD3V0J4 is designed to protect voltage sensitive electronic components from ESD and other transients. Excellent clamping capability, low leakage, low capacitance, and fast response time provide best in class protection on designs that are exposed to ESD. The combination of small size, low capacitance, and high level of ESD protection makes them a flexible solution for applications such as HDMI, Display Port TM, and MDDI interfaces. It is designed to replace multi-layer varistors (MLV) in consumer equipment applications such as mobile phone, notebook, PAD, STB, LCD TV etc.

### Features

- Uni-directional ESD protection of four lines
- Low capacitance: 9 pF(Typ)
- Low reverse stand-off voltage: 3V
- Low reverse clamping voltage
- Low leakage current
- Excellent package: 2.10mm×1.25mm×0.96mm
- Fast response time
- IEC 61000-4-2 Level 3 ESD protection

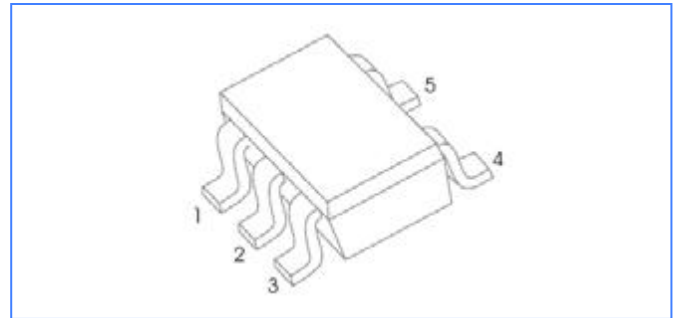

### Functional Diagram

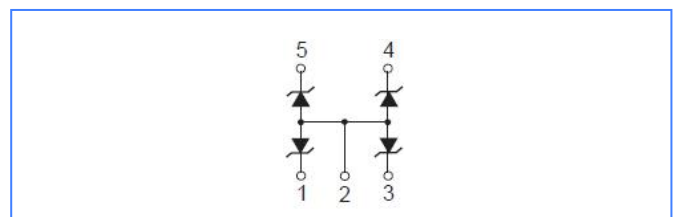

### Applications

- Computers and peripherals
- Audio and video equipment
- Cellular handsets and accessories
- Portable electronics
- Other electronics equipments communication systems

### Absolute Maximum Ratings(T<sub>amb</sub>=25°C unless otherwise specified)

Parameter	Symbol	Value	Unit
Peak Pulse Power (8/20μs)	P <sub>PP</sub>	20	Watts
ESD per IEC 61000-4-2 (Air)	V <sub>ESD</sub>	±9	KV
ESD per IEC 61000-4-2 (Contact)		±8	KV
Lead Soldering Temperature	T <sub>L</sub>	260 (10 sec)	°C
Operating Temperature Range	T <sub>J</sub>	-55 to +150	°C
Storage Temperature Range	T <sub>STJ</sub>	-55 to +150	°C

**Electrical Characteristics (TA = 25 °C unless otherwise noted)**

Parameter	Symbol	Conditions	Min.	Typ.	Max.	Units
Reverse Stand-off Voltage	$V_{RWM}$				3	V
Reverse Breakdown Voltage	$V_{BR}$	$I_t = 1\text{mA}$	5.3		5.9	V
Reverse Leakage Current	$I_R$	$V_R = V_{RWM}$			1	$\mu\text{A}$
Forward voltage	$V_F$	$I_F = 10\text{mA}$			0.9	V
Clamping Voltage	$V_C$	$I_{PP} = 2.5\text{A}$ , $t_P = 8/20\mu\text{s}$			8	V
Junction Capacitance	$C_J$	$V_R = 0\text{V}$ , $f = 1\text{MHz}$		9		pF

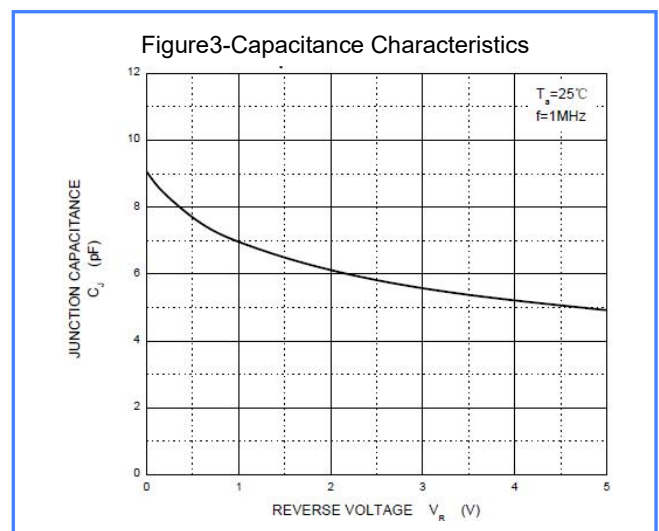
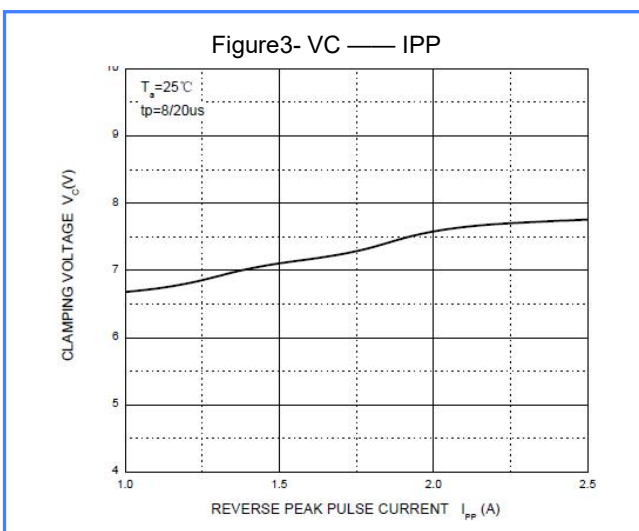
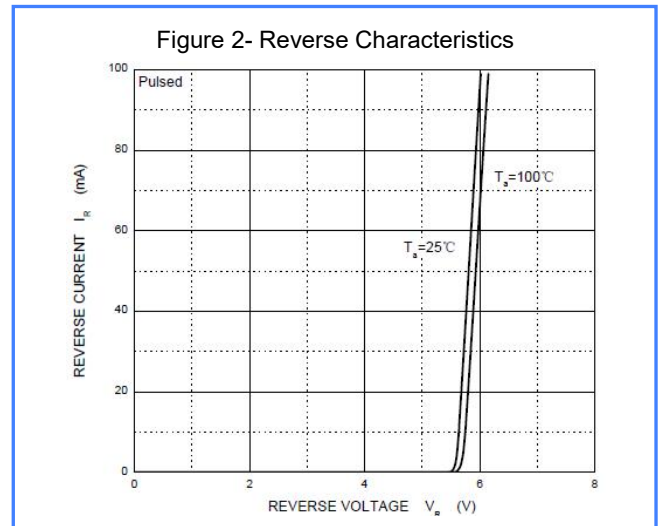
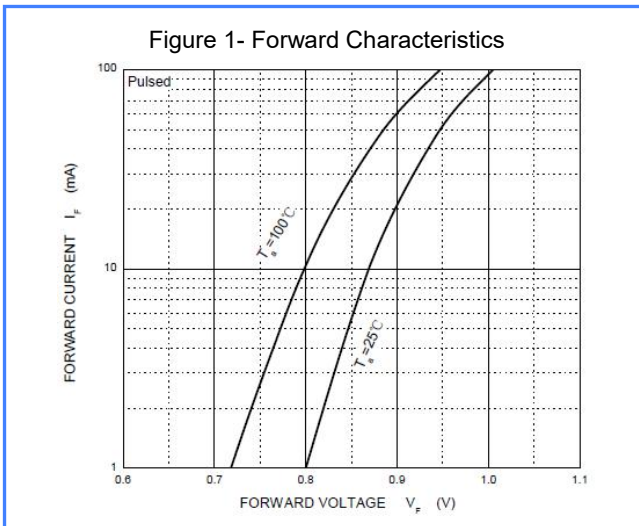
**Characteristics Curves**

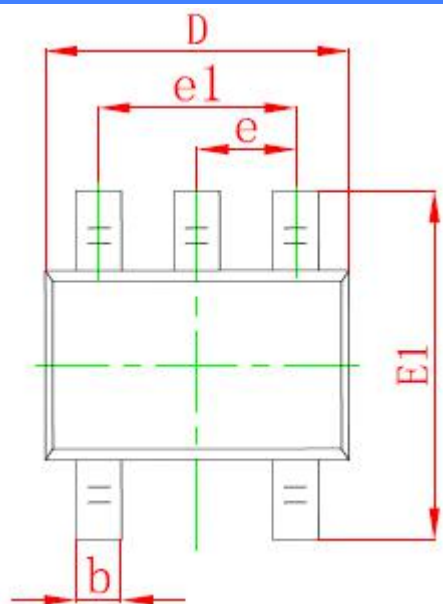
**PACKAGE OUTLINE DIMENSIONS in millimeters (inches) :SOD323**

symbol	Dimensions in millimeters		Dimensions in Inches	
	min	max	min	max
A	0.900	1.100	0.035	0.043
A1	0.000	0.100	0.000	0.004
A2	0.900	1.000	0.035	0.039
b	0.150	0.350	0.006	0.014
C	0.100	0.150	0.004	0.006
D	2.000	2.200	0.079	0.087
E	1.150	1.350	0.045	0.053
E1	2.150	2.400	0.085	0.094
e	0.650 TYP		0.026 TYP	
e1	1.200	1.400	0.047	0.055
L	0.525REF		0.026	
L1	0.260	0.460	0.010	0.018
$\theta$	0°	8°	0°	8°

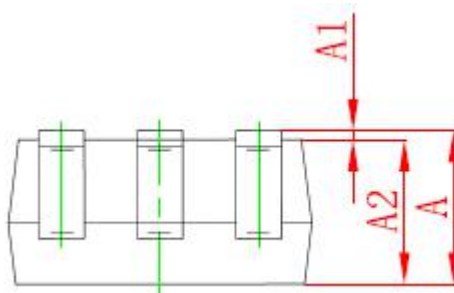
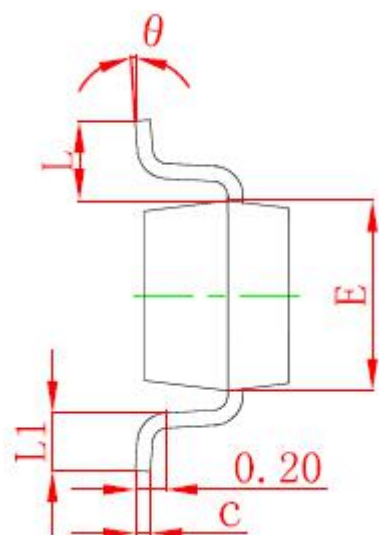
**Disclaimer**

Specifications are subject to change without notice.

The device characteristics and parameters in this data sheet can and do vary in different applications and actual device performance may vary over time.

Users should verify actual device performance in their specific applications.