

EXAMINED BY:  <i>Jony Chen</i>	EMERGING DISPLAY  TECHNOLOGIES CORPORATION	FILE NO . CAS-10183
APPROVED BY:  <i>David Chang</i>		ISSUE : AUG.26,1999
		TOTAL PAGE : 7
		VERSION : 1

CUSTOMER                      ACCEPTANCE                      SPECIFICATIONS

MODEL NO. :

20400 (EL TYPES)

FOR MESSRS :

\_\_\_\_\_

CUSTOMER'S APPROVAL

DATE :  
\_\_\_\_\_

BY :  
\_\_\_\_\_

EMERGING DISPLAY  
TECHNOLOGIES CORPORATION

MODEL NO. 20400 (EL TYPES)	VERSION 1
-------------------------------	--------------

RECORDS OF REVISION	DOC . FIRST ISSUE AUG.26,1999
---------------------	----------------------------------

DATE	REVISED PAGE NO.	SUMMARY

NUMBERING SYSTEM

Polarizer Mode	Backlight	Code value
Transflective	EL	E
Transmissive	EL	F

Backlight Color	Code Value
White	W
Blue-Green	B

E	W	2	0	4	0	0	G	E	W
---	---	---	---	---	---	---	---	---	---

LCD type + LCD color	Code Value
STN + Yellow-Green	Y
STN + Gray	G
STN + Blue	B

TABLE OF CONTENTS

NO.	ITEM	PAGE
1.	GENERAL SPECIFICATIONS -----	1
2.	MECHANICAL SPECIFICATIONS -----	1
3.	ABSOLUTE MAXIMUM RATINGS -----	2
4.	ELECTRICAL CHARACTERISTICS -----	3
5.	OPTICAL CHARACTERISTICS -----	3
6.	OUTLINE DIMENSION -----	4
7.	DETAIL DRAWING OF DOT MATRIX -----	5
8.	BLOCK DIAGRAM -----	5
9.	INTERFACE SIGNALS -----	6
10.	POWER SUPPLY -----	7
11.	DISPLAY DATA RAM ADDRESS -----	7

1. GENERAL SPECIFICATIONS

1.1 GENERAL SPECIFICATIONS

PLEASE REFER TO :

CUSTOMER ACCEPTANCE STANDARD SPECIFICATIONS :

E U - 0 0 2 A

1.2 APPLICATION NOTES FOR CONTROLLER / DRIVER : KS0066

PLEASE REFER TO :

CUSTOMER ACCEPTANCE STANDARD SPECIFICATIONS :

E U - K S 0 0 6 6

1.3 THIS INDIVIDUAL SPECIFICATIONS IS PRIOR TO GENERAL SPECIFICATIONS .

2. MECHANICAL SPECIFICATIONS

- (1) NUMBER OF CHARACTER ----- 20 CH \* 4 LINES
- (2) MODULE SIZE ----- 98.0W \* 60.0H \* 10.0D (max.) mm
- (3) EFFECTIVE AREA ----- 76.0W \* 25.2H mm
- (4) CHARACTER FONT ----- 5 \* 7 DOTS + CURSOR
- (5) CHARACTER SIZE ----- 2.95W \* 4.75H mm
- (6) CHARACTER PITCH ----- 3.55W \* 5.35H mm
- (7) DOT SIZE ----- 0.55W \* 0.55H mm
- (8) DOT PITCH ----- 0.60W \* 0.60H mm
- (9) LCD TYPE \*
- (10) DRIVING METHOD ----- 1 / 16 DUTY MULTIPLEX DRIVE
- (11) VIEWING DIRECTION ----- 6 O'CLOCK
- (12) BACK - LIGHT \*

\* PLEASE REFER TO NUMBERING SYSTEM

3. ABSOLUTE MAXIMUM RATINGS

3.1 ELECTRICAL ABSOLUTE MAXIMUM RATINGS . ( AT Ta = 25 °C )

PARAMETER	SYMBOL	MIN .	MAX .	UNIT	REMARK
POWER SUPPLY FOR LOGIC	VDD — VSS	0	7.0	V	
POWER SUPPLY FOR LCD DRIVE	VDD — VO	0	13.0	V	
INPUT VOLTAGE	VI	VSS	VDD	V	
STATIC ELECTRICITY	—	—	100	V	NOTE (1)
POWER SUPPLY FOR EL BACKLIGHT	VEL	—	AC200	Vrms	fEL=1.0KHZ 60 SEC . MAX
	fEL	—	2.0	KHZ	AC115 Vrms 60SEC.MAX.

NOTE (1) : TEST METHOD AND CONDITIONS :  
AFTER CHARGING UP 200 PF CAPACITOR BY STATED VOLTAGE ,  
THE CAPACITOR IS CONNECTED WITH INTERFACE PINS OF THE  
MODULE .

3.2 ENVIRONMENTAL ABSOLUTE MAXIMUM RATINGS .

I T E M	OPERATING		STORAGE		REMARK
	MIN .	MAX .	MIN .	MAX .	
AMBIENT TEMPERATURE	- 20 °C	60 °C	- 30 °C	70 °C	

4. ELECTRICAL CHARACTERISTICS

Ta = 25°C

VDD = 5.0 ± 0.25 V

PARAMETER	SYMBOL	CONDITION	MIN .	TYP .	MAX .	UNIT
H LEVEL INPUT VOLTAGE	VIH	————	2.2	—	—	V
L LEVEL INPUT VOLTAGE	VIL	————	—	—	0.6	V
H LEVEL OUTPUT VOLTAGE	VOH	-IOH = 0.2 mA	2.4	—	—	V
L LEVEL OUTPUT VOLTAGE	VOL	IOL = 1.2 mA	—	—	0.4	V
POWER SUPPLY CURRENT (LOGIC)	IDD	VDD = 5.0 V	—	2.0	5.0	mA
RECOMMENDED LCD DRIVING VOLTAGE	VDD - VO ∅ = 10°, θ = 0° DUTY = 1/16	Ta = -20 °C	—	4.4	—	V
		Ta = 25 °C	—	4.4	—	V
		Ta = 60 °C	—	4.4	—	V
CLOCK OSCILLATION FREQUENCY	fosc	Ta = 25 °C	—	270	—	KHZ
POWER SUPPLY FOR EL BACKLIGHT	VEL	fEL=400HZ	—	100	—	Vrms
	IEL	VEL=100V fEL=400HZ	—	3.0	—	mArms

5. OPTICAL CHARACTERISTICS .

Ta = 25°C

VDD = 5.0 V

I T E M	SYMBOL	CONDITION	MIN .	TYP .	MAX .	UNIT	NOTE	
VIEWING AREA	∅ 2 - ∅ 1	K ≥ 1.4	30	—	—	deg.	1	
CONTRAST RATIO	K	∅ = 10° θ = 0°	5	—	—	—	1	
RESPONSE TIME	tr ( rise )	∅ = 10° θ = 0°	Ta = -20°C	—	5538	—	ms	1
			Ta = 25°C	—	228	—		
			Ta = 70°C	—	104	—		
	tf ( fall )		Ta = -20°C	—	2316	—		
			Ta = 25°C	—	174	—		
			Ta = 70°C	—	85	—		
THE BRIGHTNESS OF BACKLIGHT	B	∅ = 10° θ = 0°	4	—	—	cd/m <sup>2</sup>	1, 2	

NOTE (1): PLEASE REFER TO :  
CUSTOMER ACCEPTANCE STANDARD SPECIFICATION : EU-002A

NOTE (2): POLARIZER MODE : TRANSFLECTIVE

NOTE (3): POLARIZER MODE : TRANSMISSIVE

6. OUTLINE DIMENSION

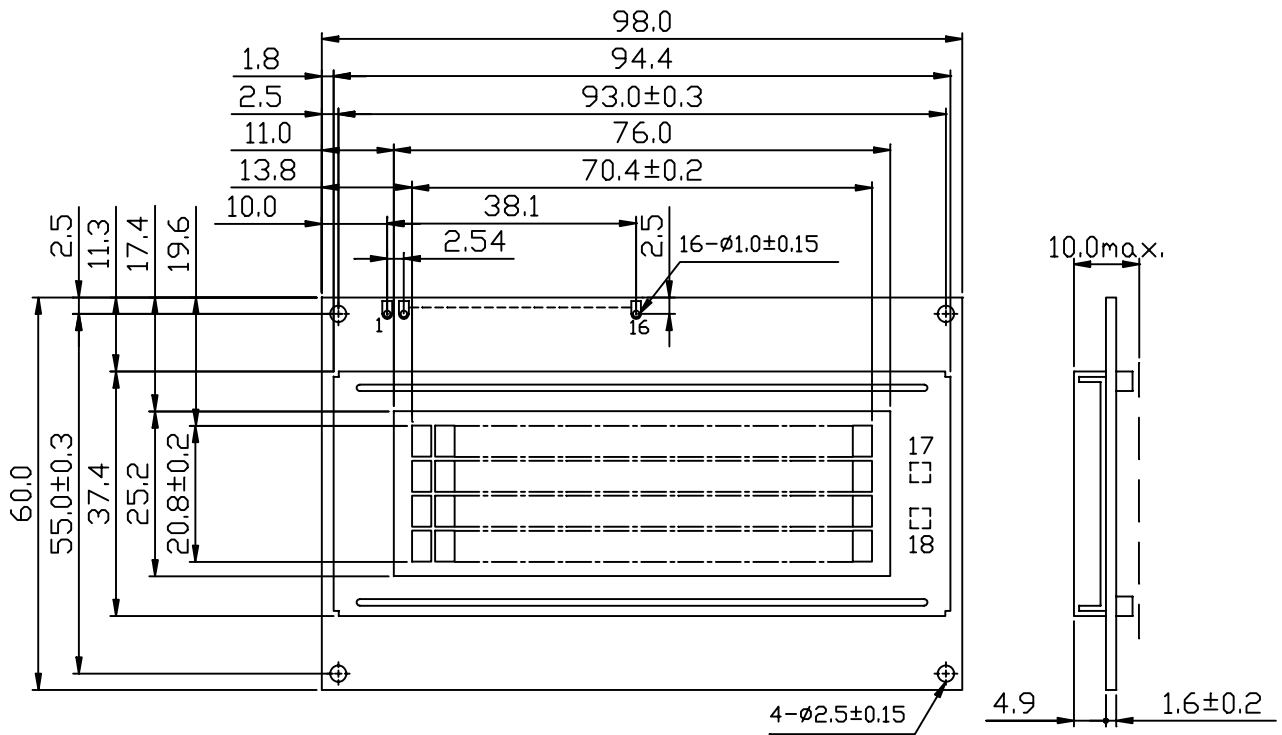

UNIT : mm  
SCALE : NTS  
NOT SPECIFIED TOLERANCE IS ± 0.5



7. DETAIL DRAWING OF DOT MATRIX

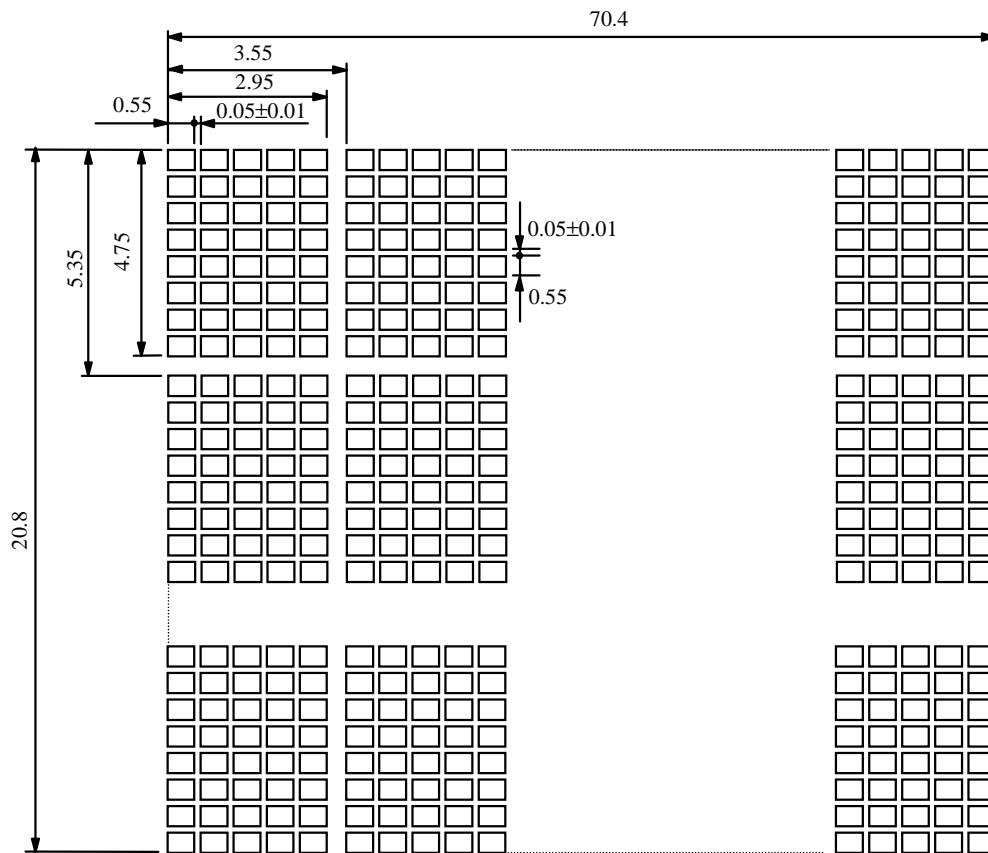

UNIT : mm  
SCALE : NTS  
NOT SPECIFIED TOLERANCE IS ± 0.1

8. BLOCK DIAGRAM

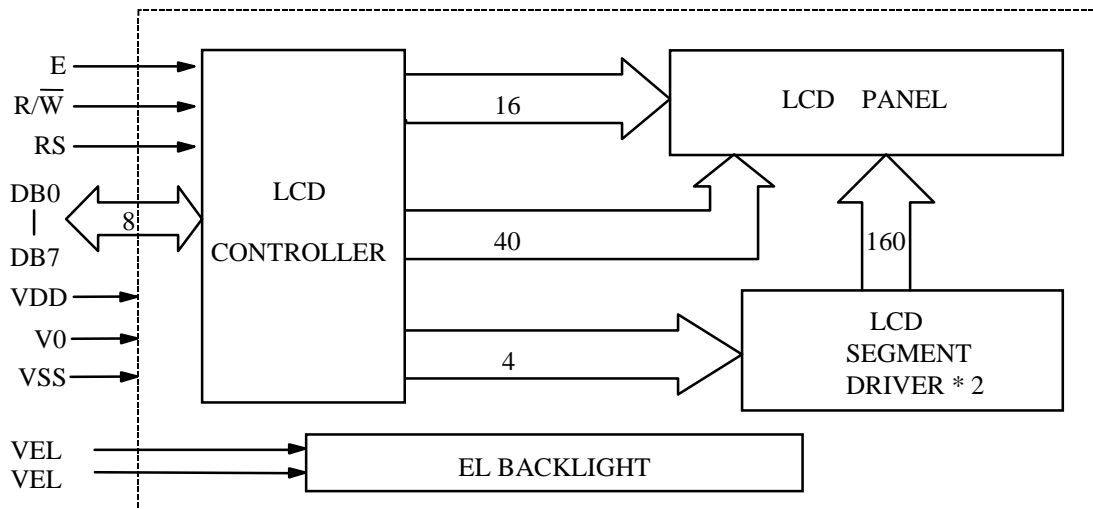

9. INTERFACE SIGNALS

PIN NO.	SYMBOL	DESCRIPTION	FUNCTION
1	VSS	GROUND	0V (GND)
2	VDD	POWER SUPPLY FOR LOGIC CIRCUIT	+5V
3	V0	LCD CONTRAST FOR LOGIC CIRCUIT	
4	RS	INSTRUCTION/DATA REGISTER SELECTION	RS = 0 : INSTRUCTION REGISTER RS = 1 : DATA REGISTER
5	$\overline{R/W}$	READ/WRITE SELECTION	$\overline{R/W}$ = 0 : REGISTER WRITE $\overline{R/W}$ = 1 : REGISTER READ
6	E	ENABLE INPUT	
7	DB0	DATA INPUT/OUTPUT LINES	4 BIT/8BIT SELECTABLE  4 BIT : DB4 - DB7 8 BIT : DB0 - DB7
8	DB1		
9	DB2		
10	DB3		
11	DB4		
12	DB5		
13	DB6		
14	DB7		
15	NC	NOT USE	
16	NC		
17	VEL	POWER SUPPLY FOR EL BACKLIGHT	
18	VEL		

10. POWER SUPPLY

10.1 POWER SUPPLY FOR LCD MODULE

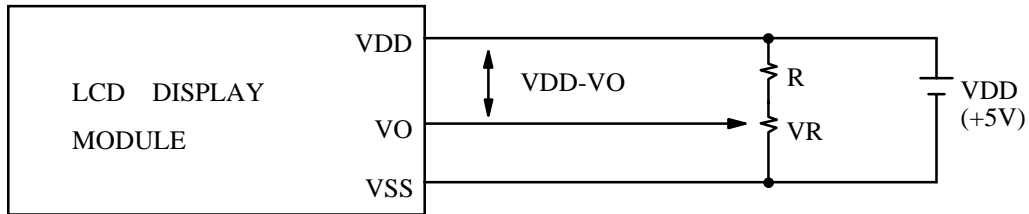

VDD - VO : LCD DRIVING VOLTAGE

VR :  $10K\Omega \sim 20K\Omega$

RECOMMENDED RESISTOR R :  $VDD - VO \geq 1.5 V$

10.2 POWER SUPPLY FOR EL BACKLIGHT

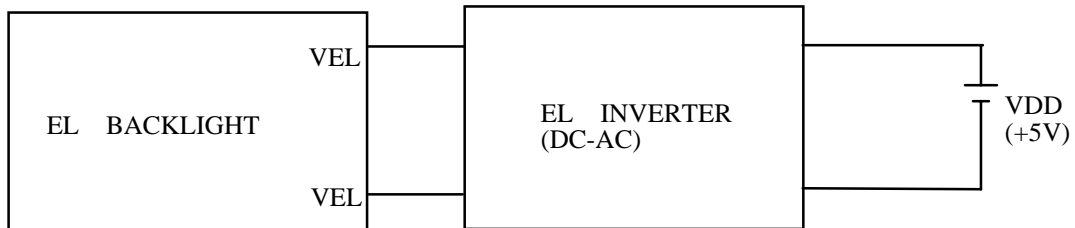

RECOMMENDED INVERTER : SOUN50350

11. DISPLAY DATA RAM ADDRESS

CHARACTER	1	2	3	4	5	6	7	8	9	10	11	12	13	14	15	16	17	18	19	20
LINE 1	80	81	82	83	84	85	86	87	88	89	8A	8B	8C	8D	8E	8F	90	91	92	93
LINE 2	C0	C1	C2	C3	C4	C5	C6	C7	C8	C9	CA	CB	CC	CD	CE	CF	D0	D1	D2	D3
LINE 3	94	95	96	97	98	99	8A	9B	9C	9D	9E	9F	A0	A1	A2	A3	A4	A5	A6	A7
LINE 4	D4	D5	D6	D7	D8	D9	DA	DB	DC	DD	DE	DF	E0	E1	E2	E3	E4	E5	E6	E7