

Flash**3.3V 2 Gbit (2 x 1 Gbit)
SPI-NAND Flash Memory****PRODUCT LIST**

Parameters	Values
V _{CC}	3.3V
Width	x1, x2 ¹ , x4
Frequency	104MHz
Internal ECC Correction	1-bit
Transfer Rate	9.6ns
Loading Throughput	104MT/s
Power-up Ready Time	1ms (maximum value)
Max Reset Busy Time	1ms (maximum value)

Note: 1. x2 PROGRAM operation is not defined.

FEATURES

- Voltage Supply: 3.3V (2.7V~3.6V)
- Organization
 - Memory Cell Array: (128M + 4M) x 8bit
 - Data Register: (2K + 64) x 8bit
- Automatic Program and Erase
 - Page Program: (2K + 64) Byte
 - Block Erase: (128K + 4K) Byte
- Page Read Operation
 - Page Size: (2K + 64) Byte
 - Read from Cell to Register with Internal ECC: 100us
- Memory Cell: 1bit/Memory Cell
- Support SPI-Mode 0 and SPI-Mode 3¹
- Fast Write Cycle Time
 - Program time: 400us
 - Block Erase time: 4ms
- Hardware Data Protection
 - Program/Erase Lockout During Power Transitions
- Reliable CMOS Floating Gate Technology
 - Internal ECC Requirement: 1bit/512Byte
 - Endurance: 100K Program/Erase cycles
 - Data Retention: 10 years
- Command Register Operation
- NOP: 4 cycles
- OTP Operation
- Bad-Block-Protect
- Boot Read
- Double Die Operation
- Operating temperature
 - Commercial: 0°C to +70°C

Note: 1. Mode 0: CPOL = 0, CPHA = 0; Mode 3: CPOL = 1, CPHA = 1

ORDERING INFORMATION

Product ID	Speed	Package		Comments
F50L2G41LB-104YG2M	104MHz	8-contact WSON	8x6mm	Pb-free
F50L2G41LB-104YG2ME	104MHz	8-contact WSON (without expose metal pad)		Pb-free

GENERAL DESCRIPTION

The device is a 2Gb SLC SPI-NAND Flash memory, which is stacked by two 1Gb chips for some special operations and applications. Please refer to the chapter of Double Die Operation for the detail.

The serial electrical interface follows the industry-standard serial peripheral interface (SPI), providing a cost-effective non-volatile memory storage solution in systems where pin count must be kept to a minimum. The 1Gb SLC SPI-NAND Flash memory device is based on the standard parallel NAND Flash, but new command protocols and registers are defined for SPI operation. It is also an alternative to SPI-NOR, offering superior write performance and cost per bit over SPI-NOR.

The command set resembles common SPI-NOR command set, modified to handle NAND-specific functions and new features. New features include user-selectable internal ECC. With internal ECC enabled, ECC code is generated internally when a page is written to the memory array. The ECC code is stored in the spare area of each page. When a page is read to the cache

register, the ECC code is calculated again and compared with the stored value. Errors are corrected if necessary. The device either outputs corrected data or returns an ECC error status.

The memory is divided into blocks that can be erased independently so it is possible to preserve valid data while old data is erased. The device contains 1024 blocks, composed by 64 pages consisting in two NAND structures of 32 series connected Flash cells. Each page consists 2112-Byte and is further divided into a 2048-Byte data storage area with a separate 64-Byte spare area. The 64-Byte area is typically used for memory and error management.

The pins serve as the ports for signals. The device has six signal lines plus V_{CC} and ground (GND, V_{SS}). The signal lines are SCK (serial clock), SI (command and data input), SO (response and data output), and control signals CS#, HOLD#, WP#.

PIN CONFIGURATION (TOP VIEW)

8-Contact WSON

(WSON 8C, 8mmx6 mm Body, 1.27mm Contact Pitch)

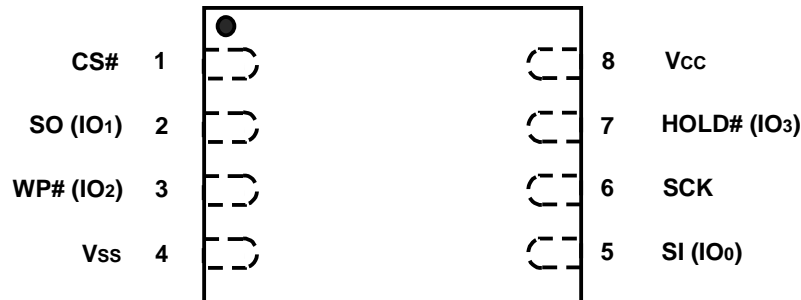

Pin Description

Pin Name	Functions
CS#	Chip Select (Input) The device is activated ⁽¹⁾ /deactivated ⁽²⁾ as CS# is driven LOW/HIGH. After power-on, the device requires a falling-edge on CS# before any command can be written. The device goes to standby mode when no PROGRAM, ERASE, or WRITE STATUS REGISTER operation is in progress.
HOLD# / IO ₃	Hold (Input) / IO₃ (Input/Output) Hold pauses any serial communication with the device without deselecting it ⁽³⁾ . When driven LOW, SO is at high impedance (Hi-Z), and all inputs in SI and SCK are ignored; CS# also should be driven LOW. HOLD# must not be driven during x4 operation; it means HOLD function is only available for standard and x2 SPI.
WP# / IO ₂	Write Protect (Input) / IO₂ (Input/Output) WP# is driven LOW to prevent writing the Feature Registers. The WP-E bit in Protection Register controls the function of WP#, and the other bits in Register can protect a specific portion by hardware. When WP-E=1, the device is in the Hardware-protection mode that WP# functions as a dedicated active low input pin for the Write Protect of the device. If WP-E=1 and WP# goes LOW, the device will become READ-only. When WP-E=0, the device is in the Software-protection mode that only Protection Register can be protected. WP# functions as a data I/O pin. WP# must not be driven during x4 operation; it means Write Protect function is only available for standard and x2 SPI.
SCK	Serial Clock (Input) SCK provides serial interface timing. Address, commands, and data in SI are latched on the rising edge of SCK. Output (data in SO) is triggered after the falling-edge of SCK. The clock is valid only when the device is active. ⁽⁴⁾
SI / IO ₀	Serial Data Input (Input) / IO₀ (Input/Output) SI transfers data serially into the device. Device latches addresses, commands, and program data in SI on the rising-edge of SCK. SI must not be driven during x2 or x4 READ operation.
SO / IO ₁	Serial Data Output (Output) / IO₁ (Input/Output) SO transfers data serially out of the device on the falling-edge of SCK. SO must not be driven during x2 or x4 PROGRAM operation.
V _{CC} ⁽⁵⁾	Power V _{CC} is the power supply for device.
V _{SS} ⁽⁵⁾	Ground
NC	No Connection Not internally connected.

Note:

1. CS# places the device in active power mode.
2. CS# deselects the device and places SO at high impedance.
3. It means HOLD# input doesn't terminate any READ, PROGRAM, or ERASE operation currently in progress.
4. SI and SO can be triggered only when the clock is valid.
5. Connect all V_{CC} and V_{SS} pins of each device to common power supply outputs. Do not leave V_{CC} or V_{SS} disconnected.

Double Die Operation

The 2Gb Device is a double-die-stacked product, please refer to the figure below.

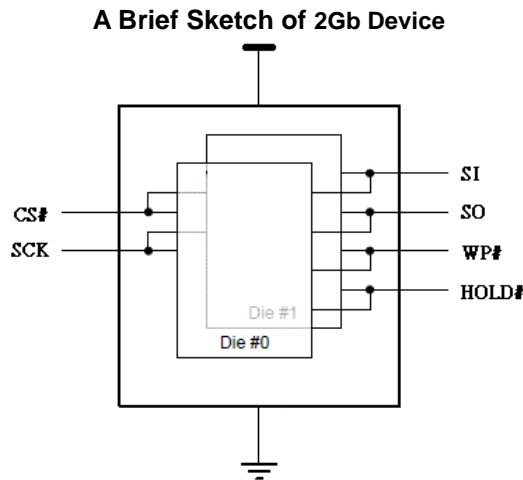

All signal pins are shared by the stacked dies within the package. Each die is assigned a “Die address (Die ID#)” in the factory, in the sequence of 00h, 01h, etc. Only a single die is active to have the control of the SPI bus to communicate with the external SPI controller at any given time.

Software Die Select command C2h is used to set any single die to be active according to the 8-bit Die ID following the command. Both dies will be reset to Power-Up state after Reset command FFh. Die#0 will always be active after Power-Up or Reset. The active die is available to accept any instruction issued by the controller and perform specific operations, while the inactive die does not accept any other commands except C2h and FFh.

However, the inactive die can still perform internal Program/ Erase operation which was initiated when the die was active. Therefore, the “concurrent operations”, such as “Read (on active die) while Program/ Erase (on inactive die)” and “Double-die Program/ Erase (on both active and inactive dies)”, are feasible. Software Die Select command C2h will only change the active/ inactive status of the stacked dies without interrupting any on-going Program/ Erase operation.

“Concurrent operations” can improve system Program/ Erase throughput and resume activities in certain applications. In case a wrong Die address is input to the device, both dies may become inactive. In such a case, a new Double Die operation, which is a new Software Die Select command C2h followed by a correct Die address (00h or 01h), is required to re-select an active die.

Double Die Operation Timing

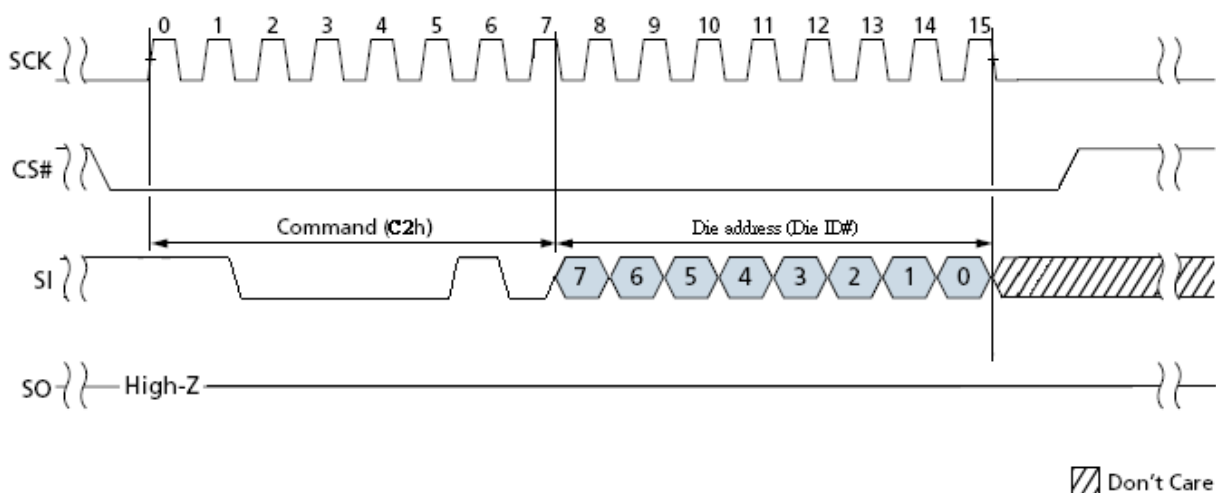

BLOCK DIAGRAM

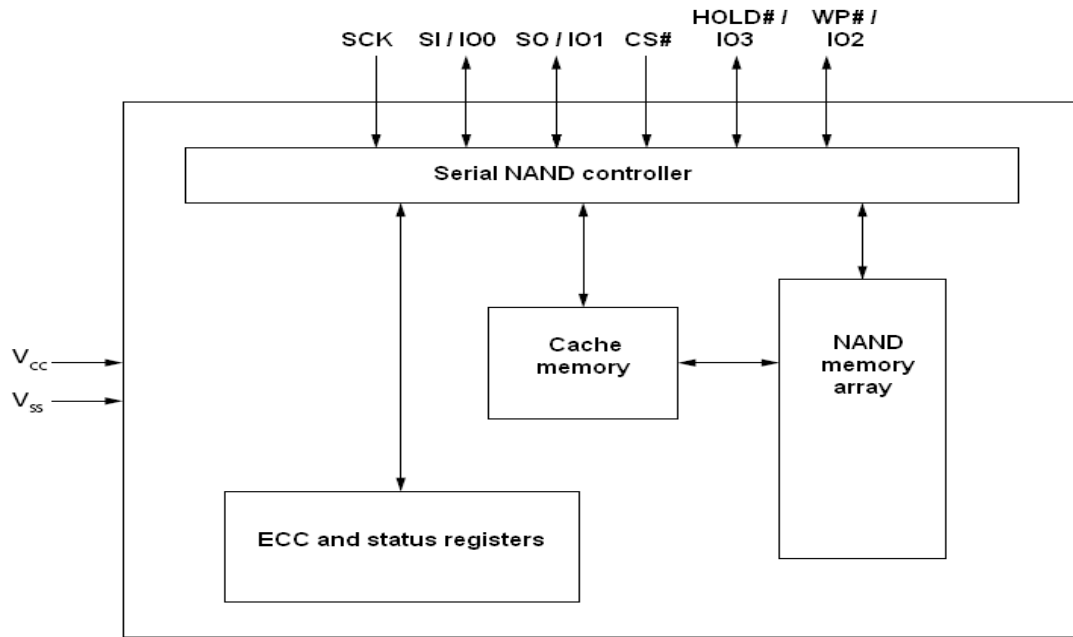

ARRAY ORGANIZATION

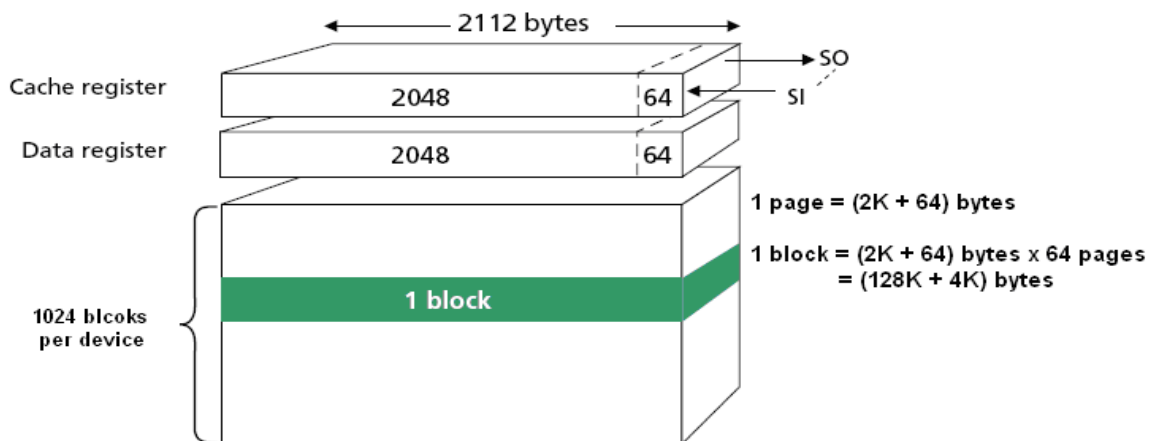

Array Address

Data Bits	0	1	2	3	4	5	6	7	Address
1 st byte	A ₀	A ₁	A ₂	A ₃	A ₄	A ₅	A ₆	A ₇	Column Address
2 nd byte	A ₈	A ₉	A ₁₀	A ₁₁	X	X	X	X	Column Address
3 rd byte	A ₁₂	A ₁₃	A ₁₄	A ₁₅	A ₁₆	A ₁₇	A ₁₈	A ₁₉	Row Address
4 th byte	A ₂₀	A ₂₁	A ₂₂	A ₂₃	A ₂₄	A ₂₅	A ₂₆	A ₂₇	Row Address
5 th byte	X	X	X	X	X	X	X	X	Dummy Address

Note:

Column Address: Starting Address of the Register.

X = don't care.

The device ignores any additional input of address cycles than required.

COMMAND SET

Function	Op Code	Address Byte	Dummy Byte	Data Bytes
BLOCK ERASE	D8h	3	0	0
GET FEATURE ⁽¹⁾	0Fh	1	0	1
SET FEATURE	1Fh	1	0	1
WRITE DISABLE	04h	0	0	0
WRITE ENABLE	06h	0	0	0
PROGRAM LOAD	02h	2	0	1 to 2112
PROGRAM LOAD x4 ⁽²⁾	32h	2	0	1 to 2112
PROGRAM LOAD RANDOM DATA	84h	2	0	1 to 2112
PROGRAM LOAD RANDOM DATA x4 ⁽²⁾	34h	2	0	1 to 2112
PROGRAM EXECUTE	10h	3	0	0
PAGE READ	13h	3	0	0
READ FROM CACHE	03h, 0Bh	2	1	1 to 2112
READ FROM CACHE with 4Byte Address	0Ch	2	3	1 to 2112
READ FROM CACHE x2	3Bh	2	1	1 to 2112
READ FROM CACHE x2 with 4Byte Address	3Ch	2	3	1 to 2112
READ FROM CACHE x4 ⁽²⁾	6Bh	2	1	1 to 2112
READ FROM CACHE x4 with 4Byte Address ⁽²⁾	6Ch	2	3	1 to 2112
FAST READ X2 IO	BBh	2	1	1 to 2112
FAST READ X2 IO with 4Byte Address	BCh	2	3	1 to 2112
FAST READ X4 IO	EBh	2	2	1 to 2112
FAST READ X4 IO with 4Byte Address	ECh	2	5	1 to 2112
READ ID ⁽³⁾	9Fh	1	0	2
RESET	FFh	0	0	0
SOFTWARE DIE SELECT	C2h	1	0	0

Note:

1. Refer to Feature Register.
2. Command/Address is 1-bit input per clock period, data is 4-bit input/output per clock period.
3. Address is 00h to get JEDEC ID

Absolute Maximum Ratings

Parameter	Symbol	Rating	Unit
Voltage on any pin relative to V_{SS}	V_{CC}	-0.6 to +4.6	V
	V_{IN}	-0.6 to +4.6	
	V_{IO}	-0.6 to $V_{CC} + 0.3$ (< 4.6)	
Temperature Under Bias	T_{BIAS}	-40 to +125	°C
Storage Temperature	T_{STG}	-65 to +150	°C
Short Circuit Current	I_{OS}	5	mA

Note:
Permanent device damage may occur if ABSOLUTE MAXIMUM RATINGS are exceeded. Functional operation should be restricted to the conditions as detailed in the operational sections of this data sheet. Exposure to absolute maximum rating conditions for extended periods may affect reliability.

Recommended Operating Conditions

(Voltage reference to GND, $T_A = 0$ to 70°C)

Parameter	Symbol	Min.	Typ.	Max.	Unit
Supply Voltage	V_{CC}	2.7	3.3	3.6	V
Supply Voltage	V_{SS}	0	0	0	V

DC and Operation Conditions

(Recommended operating conditions otherwise noted)

Parameter		Symbol	Test Conditions	Min.	Typ. ²	Max.	Unit
Operating Current	Page Read with Serial Access	I_{CC1}	$f_C=104\text{MHz}$, $CS\#=V_{IL}$, $I_{OUT}=0\text{mA}$	-	16	20	mA
	Program	I_{CC2}	-	-	16		
	Erase	I_{CC3}	-	-	16		
Stand-by Current (TTL)		I_{SB1}	$CS\#=V_{IH}$, $WP\#=0V/V_{CC}$	-	-	1	mA
Stand-by Current (CMOS)		I_{SB2}	$CS\#=V_{CC}-0.2$, $WP\#=0V/V_{CC}$	-	10	50	uA
Input Leakage Current		I_{LI}	$V_{IN}=0$ to V_{CC} (max)	-	-	± 10	uA
Output Leakage Current		I_{LO}	$V_{OUT}=0$ to V_{CC} (max)	-	-	± 10	uA
Input High Voltage		V_{IH}^1	-	$0.7 \times V_{CC}$	-	$V_{CC} + 0.3$	V
Input Low Voltage, All inputs		V_{IL}^1	-	-0.3	-	$0.2 \times V_{CC}$	V
Output High Voltage Level		V_{OH}	$I_{OH}=-20\text{uA}$	$0.7 \times V_{CC}$	-	-	V
Output Low Voltage Level		V_{OL}	$I_{OL}=1\text{mA}$	-	-	$0.15 \times V_{CC}$	V

Note:

- V_{IL} can undershoot to -0.4V and V_{IH} can overshoot to $V_{CC}+0.4\text{V}$ for durations of 20ns or less.
- Typical value are measured at $V_{CC}=3.3\text{V}$, $T_A=25^\circ\text{C}$. Not 100% tested.

Valid Block and Error Management

Description	Requirement
Minimum / Maximum number of valid block number of block	1004 / 1024
Bad block mark	Non FFh
Mark location	Column 2048 of page 0 and page 1

Note:

1. The device may include initial invalid blocks when first shipped. Additional invalid blocks may develop while being used. The number of valid blocks is presented with both cases of invalid blocks considered. Invalid blocks are defined as blocks that contain one or more bad bits which cause status failure during program and erase operation. Do not erase or program factory-marked bad blocks. Refer to the attached technical notes for appropriate management of initial invalid blocks.
2. The 1st block, which is placed on 00h block address, is guaranteed to be a valid block at the time of shipment and is guaranteed to be a valid block up to 1K program/erase cycles with 1bit/512Byte ECC.

AC Test Condition

($T_A=0$ to 70°C , $V_{CC}=2.7\text{V}\sim 3.6\text{V}$)

Parameter	Condition
Input Pulse Levels	$0.2V_{CC}$ to $0.8V_{CC}$
Input Rise and Fall Times	Max: 2.4ns
Input and Output Timing Levels	$V_{CC}/2$
Output Load	1 TTL Gate and $C_L=15\text{pF}$

Capacitance

($T_A=25^\circ\text{C}$, $V_{CC}=3.3\text{V}$, $f=1.0\text{MHz}$)

Item	Symbol	Test Condition	Min.	Max.	Unit
Input / Output Capacitance	$C_{I/O}$	$V_{IL} = 0\text{V}$	-	8	pF
Input Capacitance	C_{IN}	$V_{IN} = 0\text{V}$	-	8	pF

Note: Capacitance is periodically sampled and not 100% tested.

Read / Program / Erase Timing Characteristics

Parameter	Symbol	Min.	Typ.	Max.	Unit
Average Program Time	t_{PROG}	-	400	900	us
Number of Partial Program Cycles in the Same Page	NOP	-	-	4	Cycle
Block Erase Time	t_{BERS}	-	4	10	ms
Data Transfer from Cell to Register with Internal ECC	t_{RD}	-	-	100	us

General Timing Characteristic

Parameter	Symbol	Min.	Max.
Clock frequency	f_C		104MHz
Hold# non-active hold time relative to SCK	t_{CD}	4.5ns	
Hold# hold time relative to SCK	t_{CH}	4.5ns	
Command deselect time	t_{CS}	80ns	
CS# Setup Time	t_{CSS}	5ns	
CS# Hold Time	t_{CSH}	5ns	
The last valid Clock low to CS# high	t_{CSCL}	5ns	
Output disable time	t_{DIS}		20ns
Hold# non-active setup time relative to SCK	t_{HC}	4.5ns	
Hold# setup time relative to SCK	t_{HD}	4.5ns	
Data input setup time	t_{SUDAT}	2ns	
Data input hold time	t_{HDDAT}	3ns	
Output hold time	t_{HO}	1.5ns	
Hold# to output Hi-Z	t_{HZ}		7ns
Hold# to output Low-Z	t_{LZ}		7ns
Clock low to output valid	t_V		8ns
Clock high time	t_{WH}	4.5ns	
Clock low time	t_{WL}	4.5ns	
Clock rise time (slew rate)	t_{CRT}	0.1V/ns	
Clock fall time (slew rate)	t_{CFT}	0.1V/ns	
WP# setup time	t_{WPS}	20ns	
WP# hold time	t_{WPH}	100ns	
Resetting time during Idle/Read/Program/Erase	t_{RST}		5/5/10/500us

Note: For first RESET condition after power up, t_{RST} will be 1ms MAX.

Technical Notes**Bus Operation**

SPI NAND supports two SPI modes:

(Mode 0) CPOL (clock polarity) = 0, CPHA (clock phase) = 0

(Mode 3) CPOL=1, CPHA=1

Input data is latched in on the rising edge of SCK, and output data is available from the falling edge of SCK for both modes. When CS# is high, keep SCK at V_{CC} (Mode 0) or V_{SS} (Mode 3). Do not begin toggling SCK until after CS# is driven LOW.

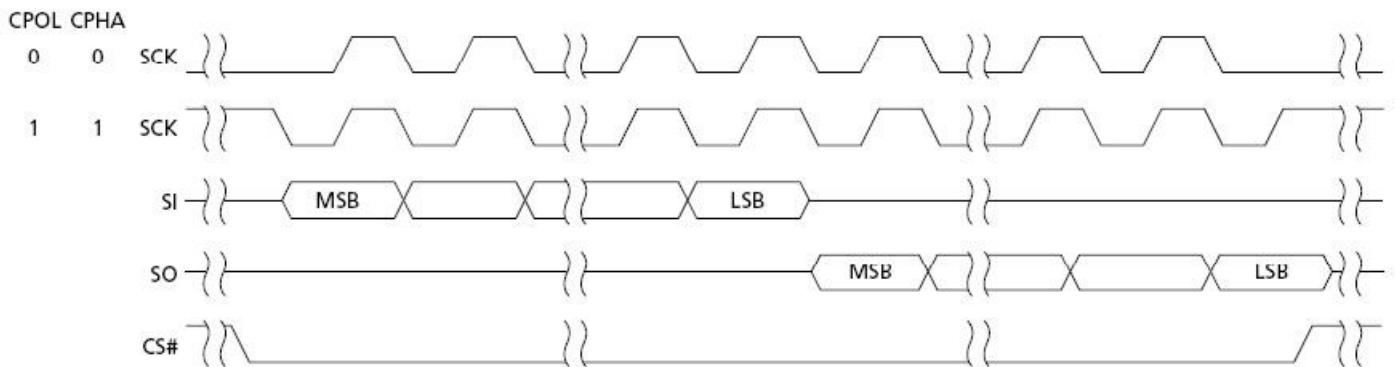
SPI Modes Timing

Feature Operations

The GET FEATURE (0Fh) and SET FEATURE (1Fh) commands are used to alter the device behavior from the default power-on behavior. These commands use a 1-Byte feature address to determine which feature is to be read or modified.

When a feature is set, it remains active until the device is power cycled or the feature is written to. Unless otherwise specified in Feature Setting Table, once the device is set, it remains set, even if a RESET (FFh) command is issued.

Feature Settings Table

Register	Acronym	Address	Data Bits							
			7	6	5	4	3	2	1	0
Protection Register	PR	A0h	PRP0	BP3	BP2	BP1	BP0	T/BP	WPE	PRP1
Configuration Register	CR	B0h	OTP-P	OTP-E	PR-L	ECC-E	Reserved	Reserved	Reserved	Reserved
Status Register	SR	C0h	Reserved	Reserved	ECC_S1	ECC_S0	P_Fail	E_Fail	WEL	OIP
Output Driver Register	ODR	D0h	Reserved	DRV_S1	DRV_S0	Reserved	Reserved	Reserved	Reserved	Reserved

GET FEATURE (0Fh) Timing

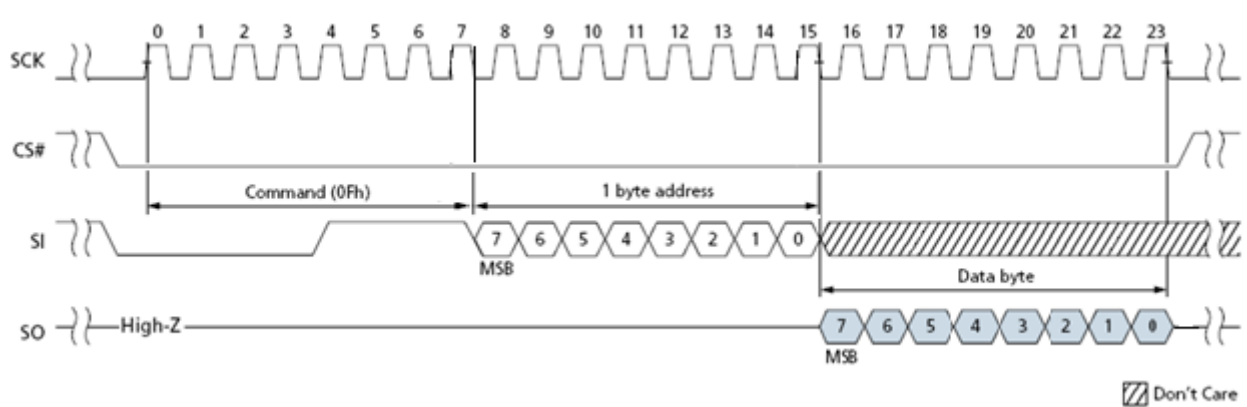

SET FEATURE (1Fh) Timing

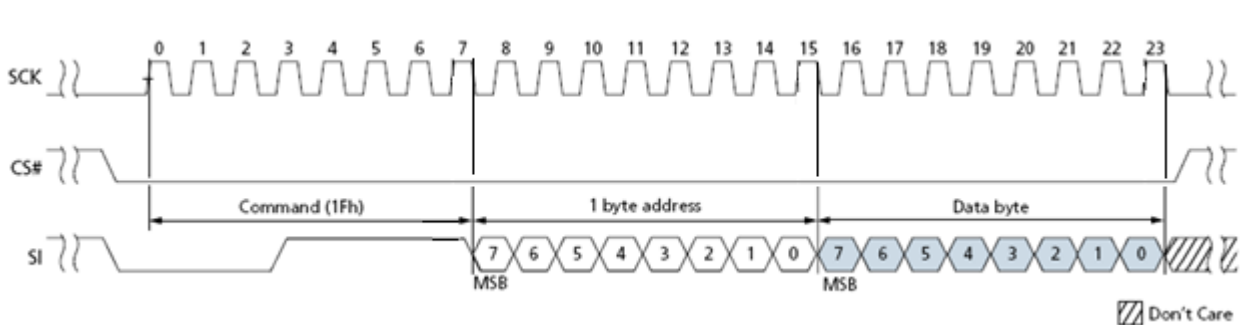

Protection Register

Protection Register Setting Table

A0h	Data Bits							
Bit	7	6	5	4	3	2	1	0
Definition	Protection Register Protect 0	Block Protect 3	Block Protect 2	Block Protect 1	Block Protect 0	Top / Bottom Protect	WP# Enable	Protection Register Protect 1
Shipment default	0	1	1	1	1	1	0	0

- Note:**
- All bits in A0h are volatile writable.
 - Once BP[3:0], T/B-P, and WPE bits are set correctly, PRP0 and PRP1 should both be set to "1" as well to allow PR-L bit being set to "1" to lock the protection in the PR (Protection Register) until next Power cycle.

Related Protection Bits of Protection Register Table

Software Protection (Controller, X4 Program/ Read is enable)				
PRP0 (7)	WPE (1)	PRP1 (0)	WP# IO2	Description
0	0	0	X	No WP# functionality, and WP# pin will always function as IO2
1	0	0	0	PR cannot be changed, and WP# pin will function as IO2 for X4 operation
1	0	0	1	PR can be changed, and WP# pin will function as IO2 for X4 operation
0	0	1	X	Power Lock Down PR, and WP# pin will always function as IO2
1	0	1	X	Set PR-L=1 is allowed, and PR is locked until next Power cycle, and WP# pin will always function as IO2
Hardware Protection (System Circuit/ PCB layout, X4 Program/ Read is disable)				
PRP0 (7)	WPE (1)	PRP1 (0)	WP# IO2	Description
X	1	0	VCC	PR can be changed
0	1	1	VCC	Power Lock Down ⁽¹⁾ PR
1	1	1	VCC	Set PR-L=1 is allowed, and PR is locked until next Power cycle
X	1	X	GND	All Write operations are blocked, and entire device (Register, Array, and OTP area) is Read-only

- Note:**
- PR means Protection Register.
 - When PRP1 = "1" and PRP0 = "0", a cycle of power-down to power-up will change the state to PRP1 = "0" and PRP0 = "0"

Block Protect Bits of Protection Register Table

BP3 (6)	BP2 (5)	BP1 (4)	BP0 (3)	T/BP (2)	Protected Rows
0	0	0	0	X	None; all unlocked
0	0	0	1	0	Upper 1/512 locked (BLK1022 & 1023)
0	0	1	0	0	Upper 1/256 locked
0	0	1	1	0	Upper 1/128 locked
0	1	0	0	0	Upper 1/64 locked
0	1	0	1	0	Upper 1/32 locked
0	1	1	0	0	Upper 1/16 locked
0	1	1	1	0	Upper 1/8 locked
1	0	0	0	0	Upper 1/4 locked
1	0	0	1	0	Upper 1/2 locked
0	0	0	1	1	Lower 1/512 locked (BLK0 & 1)
0	0	1	0	1	Lower 1/256 locked
0	0	1	1	1	Lower 1/128 locked
0	1	0	0	1	Lower 1/64 locked
0	1	0	1	1	Lower 1/32 locked
0	1	1	0	1	Lower 1/16 locked
0	1	1	1	1	Lower 1/8 locked
1	0	0	0	1	Lower 1/4 locked
1	0	0	1	1	Lower 1/2 locked
1	0	1	X	X	All locked
1	1	X	X	X	All locked

Note:

1. X = don't care
2. Any Erase or Program command for the protected area will be ignored.

Configuration Register**Configuration Register Setting Table**

B0h	Data Bits							
Bit	7	6	5	4	3	2	1	0
Definition	OTP Pages Protect	OTP Pages Enable ⁽¹⁾	Protection Register Lock	ECC Enable ⁽²⁾	Reserved	Reserved	Reserved	Reserved
Shipment default	0	0	0	1	0	0	0	0

- Note:**
1. To Program/ Read OTP area, and Read Unique ID and Parameter Page, OTP-E must be set to “1”.
 2. 1-bit internal ECC for all READ and PROGRAM operations can be enabled (ECC enable = 1) or disabled (ECC enable = 0).
 3. Once BP[3:0], T/B-P, and WP-E bits are set correctly, PRP0 and PRP1 should both be set to “1” as well to allow PR-L bit being set to “1” to lock the protection in the PR (Protection Register) until next Power cycle.
 4. Bit6 and bit4 are volatile writable.

OTP State Bits of Configuration Register Table

OTP Protect Bit (7)	OTP Enable Bit (6)	State
0	0	Normal operation (read array)
0	1	Access OTP space
1	0	Not applicable
1	1	Lock the OTP area

Status Register

Software can read status register during the NAND device operation by issuing GET FEATURE (0Fh) command, followed by the feature address C0h. The status register will output the status of the operation, refer to Status Register Setting Table, Bits of Status Register Table and ECC Status Bits of Status Register Table.

Status Register Setting Table

C0h	Data Bits							
Bit	7	6	5	4	3	2	1	0
Definition	Reserved	Reserved	ECC_Status1	ECC_Status0	Program_Fail	Erase_Fail	Write Enable Latch	Operation In Progress
Shipment default	0	0	0	0	0	0	0	0

Bits of Status Register Table

Bit Name	Mode	Description
Program fail (Bit 3)	R	P_Fail is set to 1 as a program failure has occurred. P_Fail = 1 will also be set if the user attempts to program an invalid address or a locked region. P_Fail is set to 0 during the PROGRAM EXECUTE command sequence or the RESET command.
Erase fail (Bit 2)	R	E_Fail is set to 1 as an erase failure has occurred. E_Fail = 1 will also be set if the user attempts to erase a locked region, or if ERASE operation fails. E_Fail is set to 0 at the start of the BLOCK ERASE command sequence or the RESET command.
Write enable latch (Bit 1)	W	WEL must be set to 1 to indicate the current status of the write enable latch, prior to issuing PROGRAM EXECUTE or BLOCK ERASE command. It is set by issuing WRITE ENABLE command. WEL is disabled (WEL=0) by issuing the WRITE DISABLE command.
Operation in progress (Bit 0)	R	OIP is set to 1 when the device is busy; it means a PROGRAM EXECUTE, PAGE READ, BLOCK ERASE, or RESET command is executing. OIP is cleared to 0 as the interface is in ready state.
ECC_status1 (Bit 5) ECC_status0 (Bit 4)	R	ECC Status Bits of Status Register Table shows the ECCS definitions. ECC_S is set to 00h either following a RESET, or at the beginning of the READ. It is then updated after the device completes a valid READ operation. ECC_S is invalid if ECC is disabled (via a SET FEATURE command to Bit 4 in OTP register). After power-up RESET, ECC_S is set to reflect the contents of block 0, page 0.

ECC Status Bits of Status Register Table

ECCS1 (5)	ECCS0 (4)	Description
0	0	No errors
0	1	1-bit error detected and corrected
1	0	2-bit or more than 2-bit errors detected and not corrected
1	1	Reserved

Output Driver Register

Output Driver Register Setting Table

D0h	Data Bits							
Bit	7	6	5	4	3	2	1	0
Definition	Reserved	Driver_Strength1	Deiver_Strength0	Reserved	Reserved	Reserved	Reserved	Reserved
Shipment default	0	0	1	0	0	0	0	0

Driver Strength Bits of Output Driver Register Table

DRV_S1 (6)	DRV_S0 (5)	Driver Strength
0	0	100 %
0	1	75 %
1	0	50 %
1	1	25%

Array Write Enable / Disable

The WRITE ENABLE (06h) command sets the WEL bit (in status register) to 1. This is required in the following WRITE operations that change the contents of the memory array: PAGE PROGRAM, BLOCK ERASE, and OTP PROGRAM.

Contrarily, the WRITE DISABLE (04h) command sets the WEL bit to 0. This disables PAGE PROGRAM, BLOCK ERASE, and OTP PROGRAM.

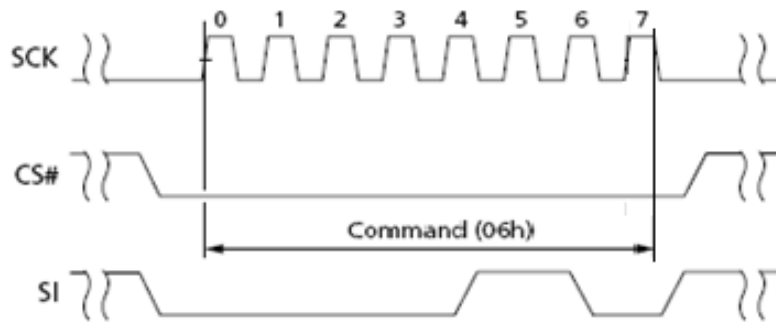
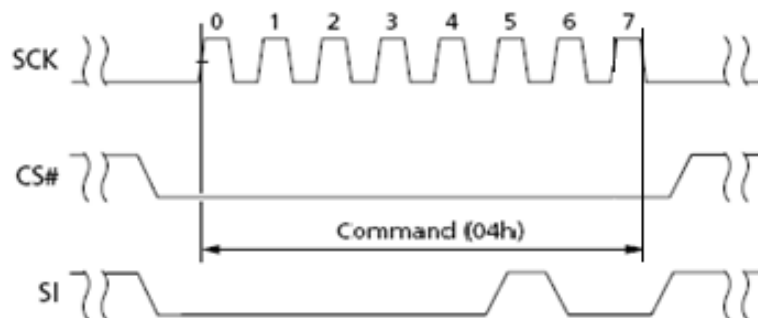
WRITE ENABLE (06h) Timing**WRITE DISABLE (04h) Timing**

Error Management

Mask Out Initial Invalid Blocks

Initial invalid blocks are defined as blocks that contain one or more initial invalid bits whose reliability is not guaranteed by ESMT. The information regarding the initial invalid blocks is called the initial invalid block information. Devices with initial invalid blocks have the same quality level as devices with all valid blocks and have the same AC and DC characteristics. An initial invalid block does not affect the performance of valid blocks because it is isolated from the bit line and the common source line by a select transistor. The system design must be able to mask out the initial invalid blocks via address mapping.

The 1st block, which is placed on 00h block address, is guaranteed to be a valid block up to 1K program/erase cycles with 1bit/512Byte ECC.

Identifying Initial Invalid Blocks

All device locations are erased (FFh) except locations where the initial invalid block(s) information is written prior to shipping. The initial invalid block(s) status is defined by the 1st byte in the spare area. ESMT makes sure that either the 1st or 2nd page of every initial invalid block has non-FFh data at the 1st byte column address in the spare area.

Do not erase or program factory-marked bad blocks. The host controller must be able to recognize the initial invalid block information and to create a corresponding table to manage block replacement upon erase or program error when additional invalid blocks develop with Flash memory usage.

Algorithm for Bad Block Scanning

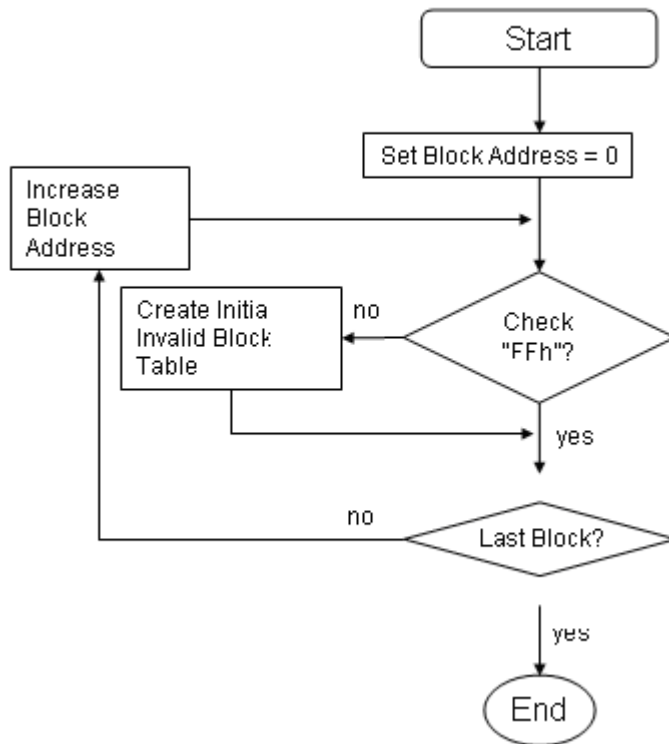

Check "FFh" at the 1st Byte column address in the spare area of the 1st and 2nd page in the block.

```

For (i=0; i<Num_of_LUs; i++)
{
  For (j=0; j<Blocks_Per_LU; j++)
  {
    Defect_Block_Found=False;

    Read_Page(lu=i, block=j, page=0);
    If (Data[column=First_Byte_of_Spare_Area]!=FFh) Defect_Block_Found=True;

    Read_Page(lu=i, block=j, page=1);
    If (Data[column=First_Byte_of_Spare_Area]!=FFh) Defect_Block_Found=True;

    If (Defect_Block_Found) Mark_Block_as_Defective(lu=i, block=j);
  }
}
  
```

Block Replacement

Within its lifetime, number of invalid blocks may increase with NAND Flash memory. Refer to the qualification report for the actual data. The following possible failure modes should be considered to implement a highly reliable system. In the case of failure after ERASE or PROGRAM in status register, block replacement should be done. Because PROGRAM status fail during a page program does not affect the data of the other pages in the same block, block replacement can be executed with a page-sized buffer by finding an erased empty block and reprogramming the current target data and copying the rest of the replaced block.

In case of READ, ECC must be employed. To improve the efficiency of memory space, it is recommended that the read or verification failure due to single bit error be reclaimed by ECC without any block replacement. The additional block failure rate does not include those reclaimed blocks.

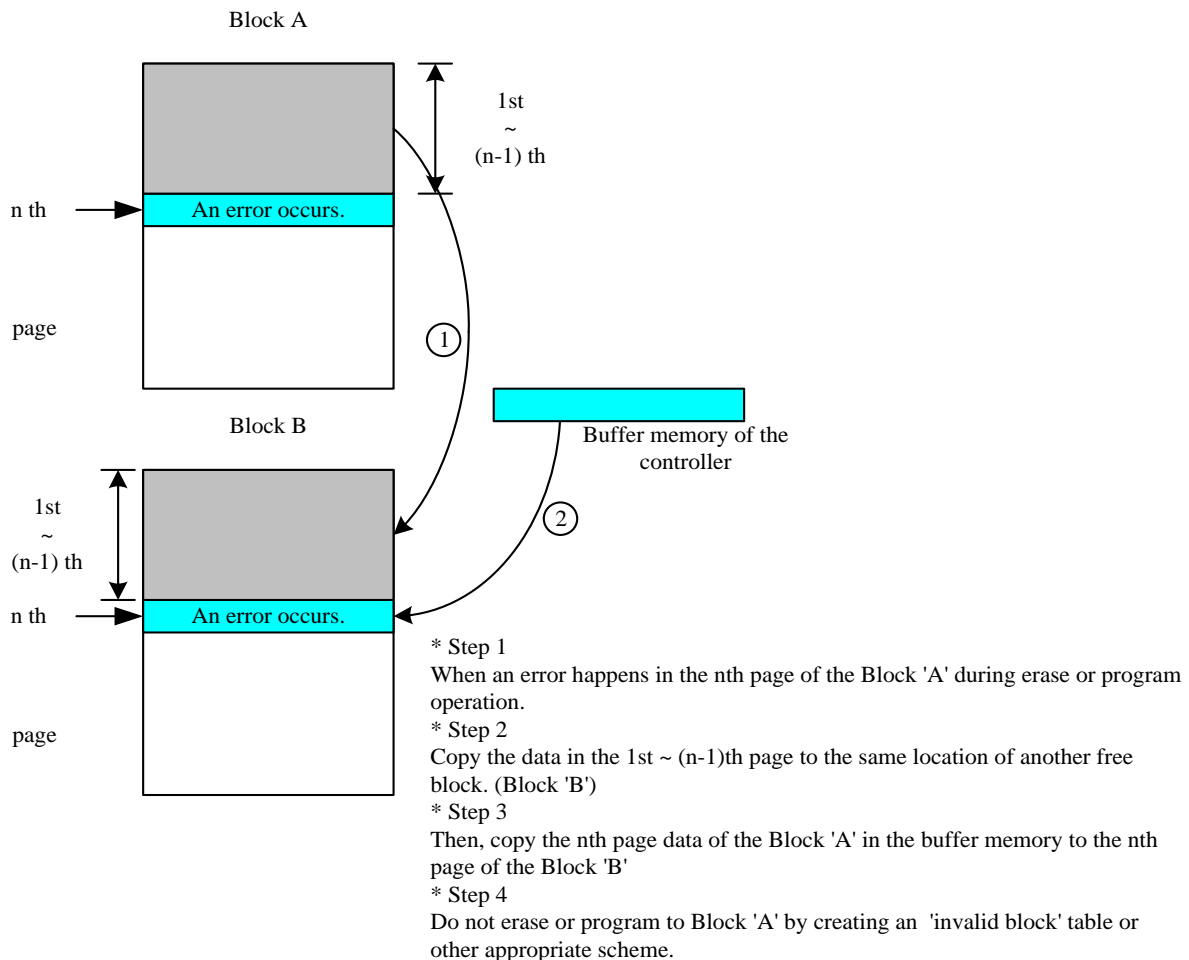

ECC Protection

ECC is enabled after device power-up, so the default PROGRAM and READ commands operate with internal ECC in the active state. During a PROGRAM operation, the device calculates an ECC code on the 2KB page in the cache register, before the page is written to the NAND Flash array. The ECC code is stored in the spare area of the page in array.

During a READ operation, the page data is read from the array to the cache register, where the ECC code is calculated and compared with the ECC code value read from the array. If a single-bit data error is discovered, the error is corrected in the cache register and only the corrected data is on the output bus.

ECC Protection Table

Max Byte Address	Min Byte Address	ECC Protected	Area	Description
1FFh (511)	000h (0)	Yes	Main 0	User data 0 ¹
3FFh (1023)	200h (512)	Yes	Main 1	User data 1 ¹
5FFh (1535)	400h (1024)	Yes	Main 2	User data 2 ¹
7FFh (2047)	600h (1536)	Yes	Main 3	User data 3 ¹
801h (2049)	800h (2048)	No		Reserved (Bad Block Marker)
803h (2051)	802h (2050)	No	Spare 0	User Data II
807h (2055)	804h (2052)	Yes	Spare 0	User Data I
80Dh (2061)	808h (2056)	Yes		ECC for Main 0
80Fh (2063)	80Eh (2062)	No		ECC for Spare 0
811h	810h	No		Reserved
813h	812h	No	Spare 1	User Data II
817h	814h	Yes	Spare 1	User Data I
81Dh	818h	Yes		ECC for Main 1
81Fh	81Eh	No		ECC for Spare 1
821h	820h	No		Reserved
823h	822h	No	Spare 2	User Data II
827h	824h	Yes	Spare 2	User Data I
82Dh	828h	Yes		ECC for Main 2
82Fh	82Eh	No		ECC for Spare 2
831h	830h	No		Reserved
833h	832h	No	Spare 3	User Data II
837h	834h	Yes	Spare 3	User Data I
83Dh	838h	Yes		ECC for Main 3
83Fh	83Eh	No		ECC for Spare 3

Note:

1. The user areas must be programmed within a single partial-page programming operation so the NAND Flash device can calculate the proper ECC bytes.
2. When internal ECC is enabled, these areas are prohibited to be programming.

Addressing for Program Operation

Within a block, the pages must be programmed consecutively from the LSB (least significant bit) page of the block to MSB (most significant bit) pages of the block. Random page address programming is prohibited. In this case, the definition of LSB page is the LSB among the pages to be programmed. Therefore, LSB page doesn't need to be page 0.

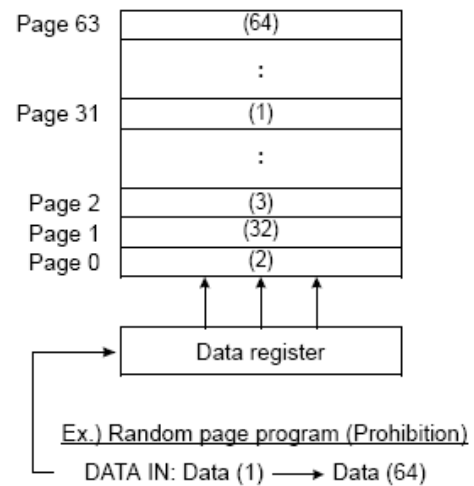
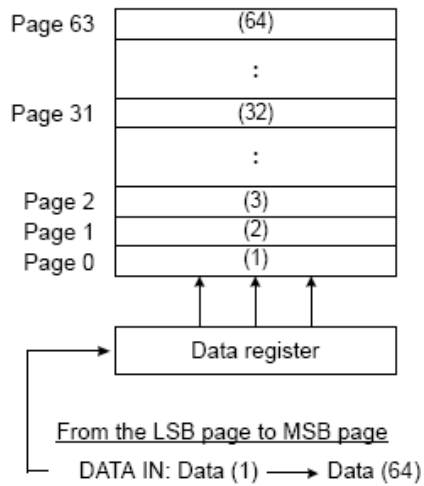

Operations and Timing Diagrams

Read Operations and Serial Output

The command sequence is follows:

- 13h (PAGE READ to cache)
- 0Fh (GET FEATURE command to read the status)
- 0Bh or 03h (READ FROM CACHE x1); 0Ch (x1) / 3Bh (x2); 3Ch (x2) / 6Bh (x4); 6Ch (x4)
- BBh (x2) TBD; BCh (x2) / EBh (x4) TBD; ECh (x4)

PAGE READ command requires 24-bit address with 8 dummy and a 16-bit row address. After row address is registered, the device starts the transfer from the main array to the cache register, and is busy for t_R time. During this time, GET FEATURE command can be issued to monitor the status of the operation. Following a status of successful completion, READ FROM CACHE command must be issued to read the data out of the cache.

READ FROM CACHE command requires 16-bit address with 4 dummy bits and a 12-bit column address for the starting byte. The starting byte can be 0 to 2011, but after the end of the cache register is reached, the data does not wrap around and SO goes to a Hi-Z state.

BBh and BCh command allow for improved random access while maintaining two IO pins: SI and SO. It is similar to 3Bh command but with the capability to input Column Address or dummy clocks two bits per clock.

The data output sequence will start from the location specified by the Column Address input and continue to the end of the Page. Once the last byte of data is output, both SI (SO0) and SO (SO1) will become Hi-Z.

PAGE READ (13h) Timing

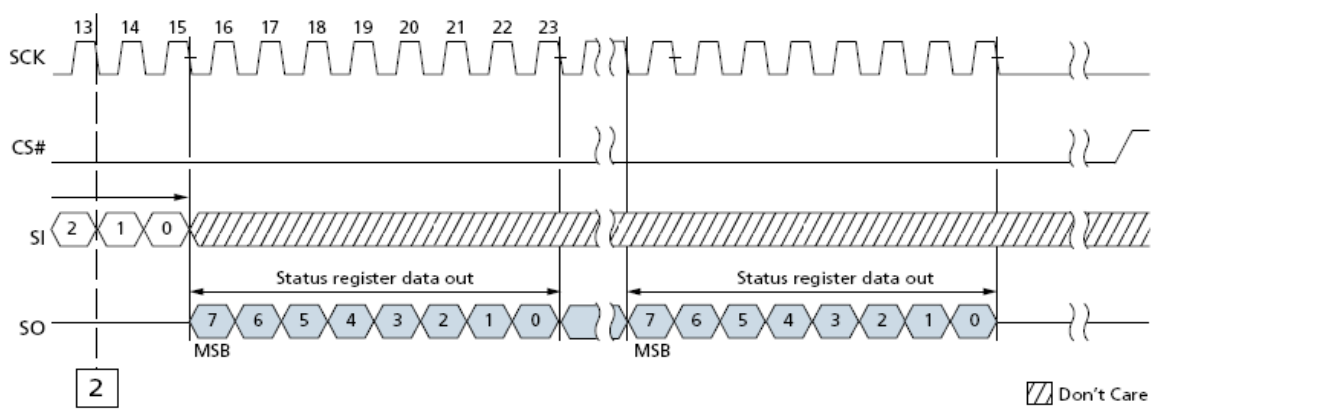
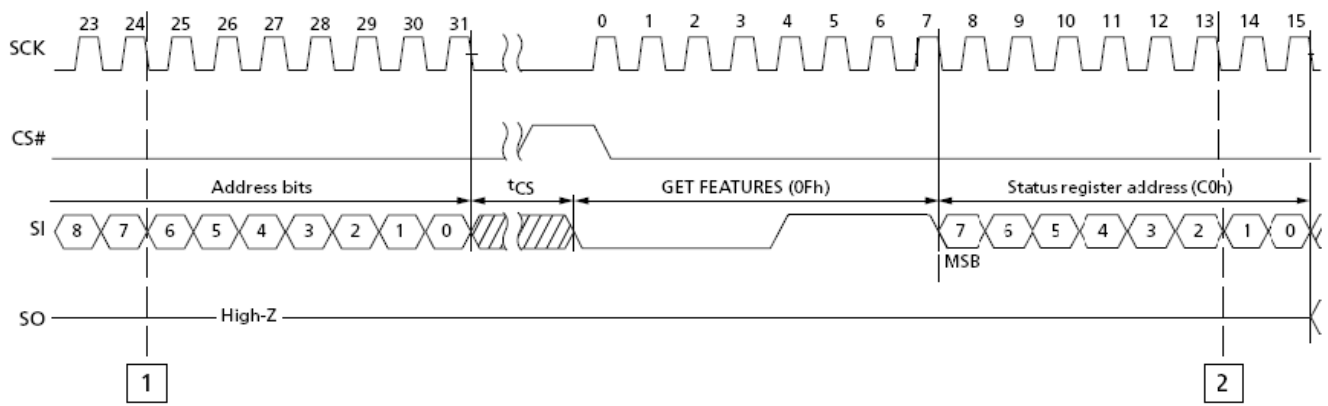
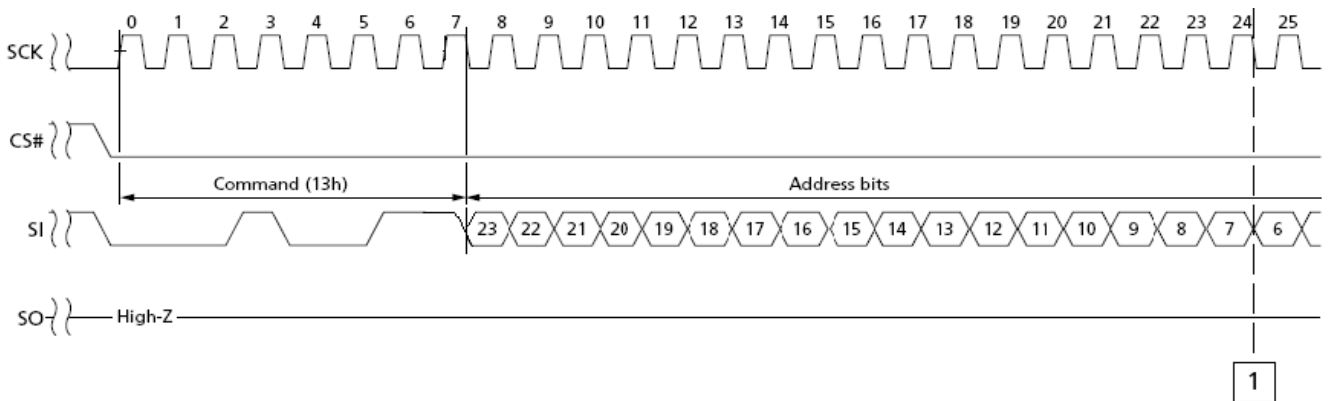

Serial Output Timing

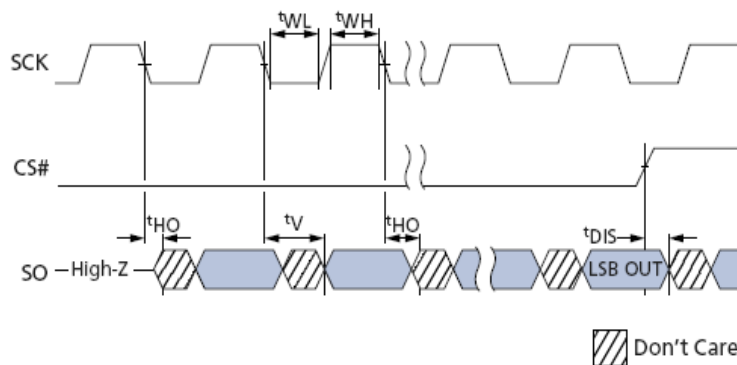

READ FROM CACHE (03h or 0Bh) Timing

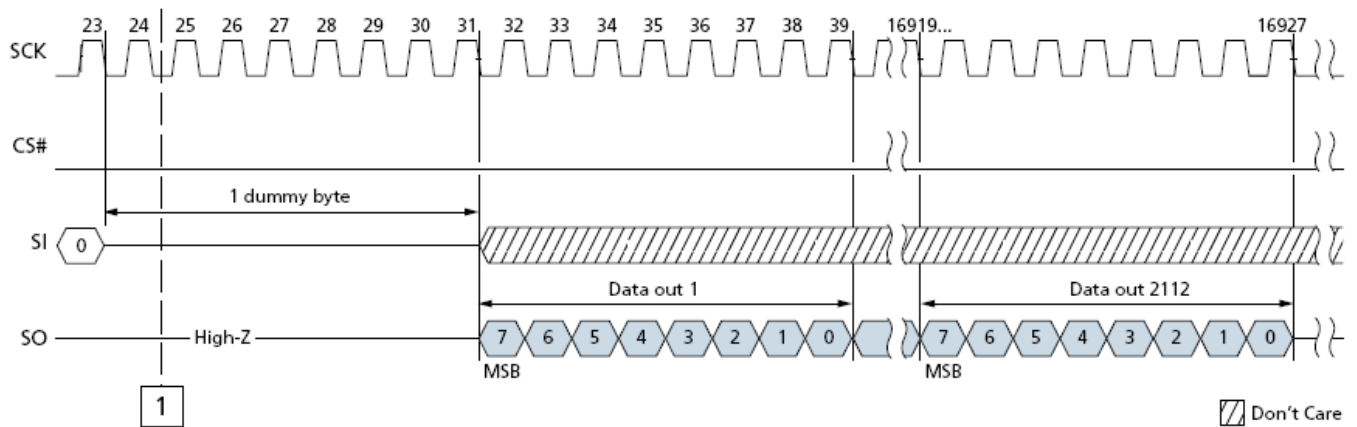
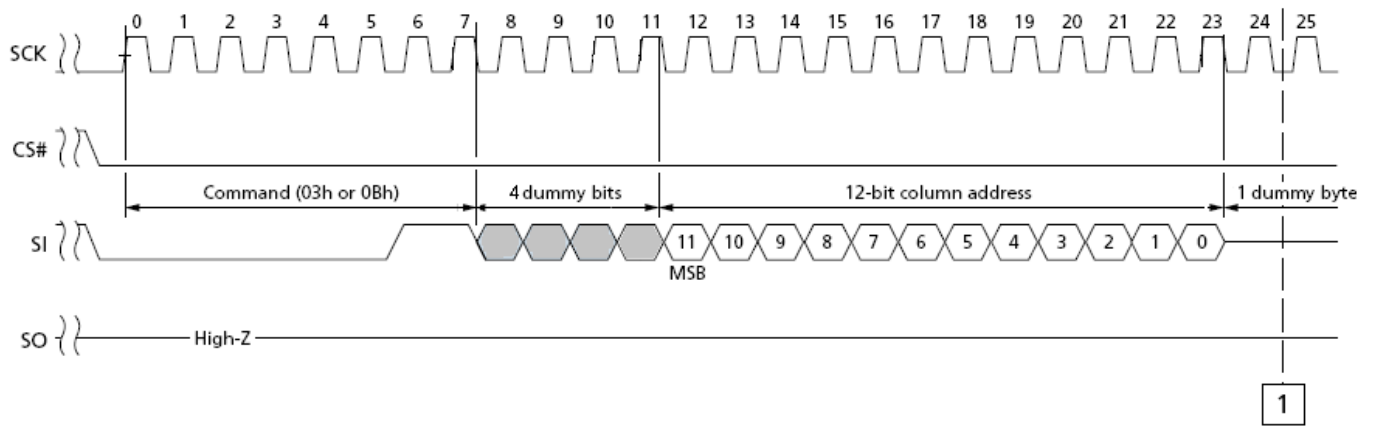

Don't Care

READ FROM CACHE with 4-Byte Address (0Ch) Timing

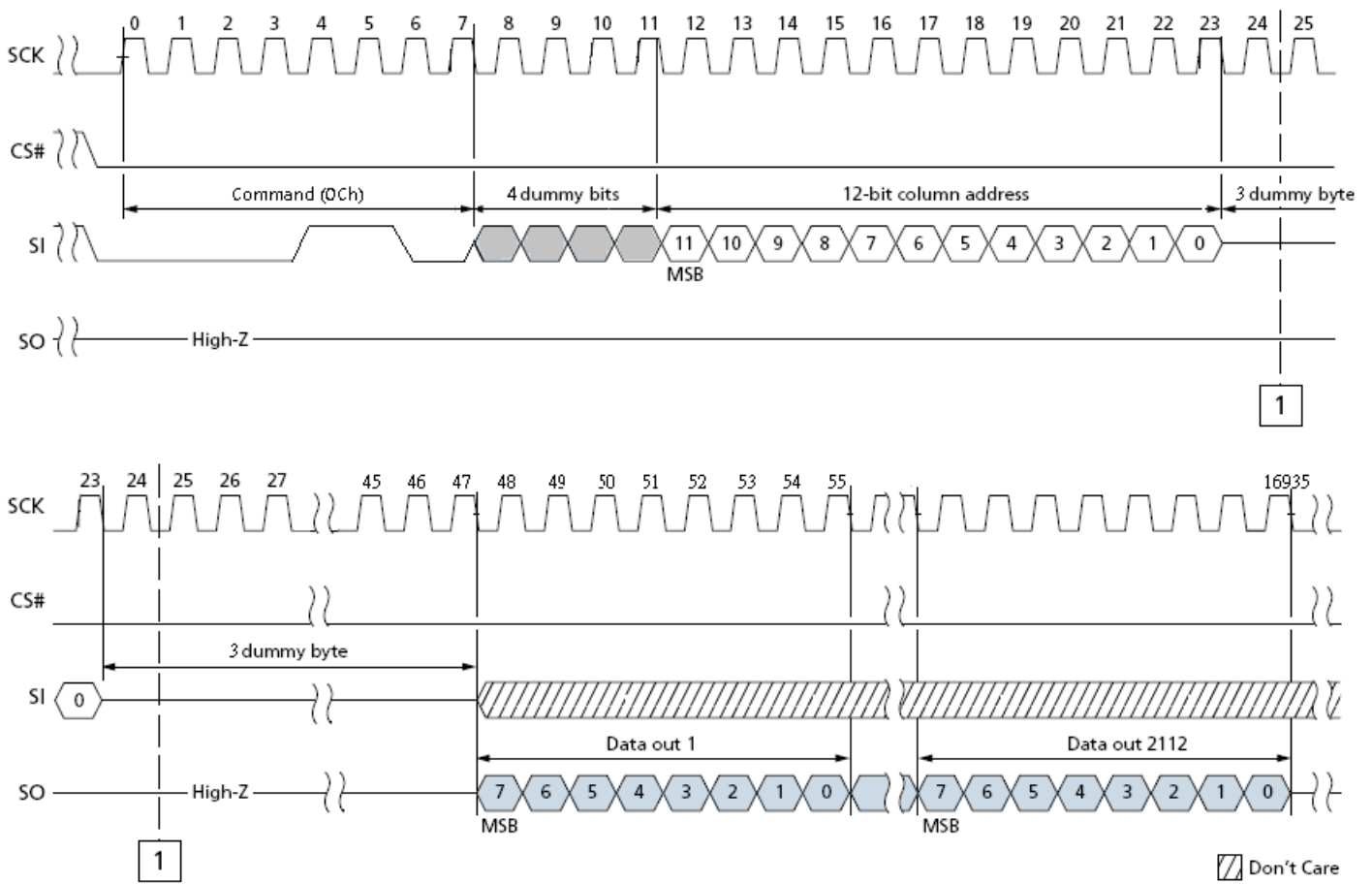

READ FROM CACHE x2 (3Bh) Timing

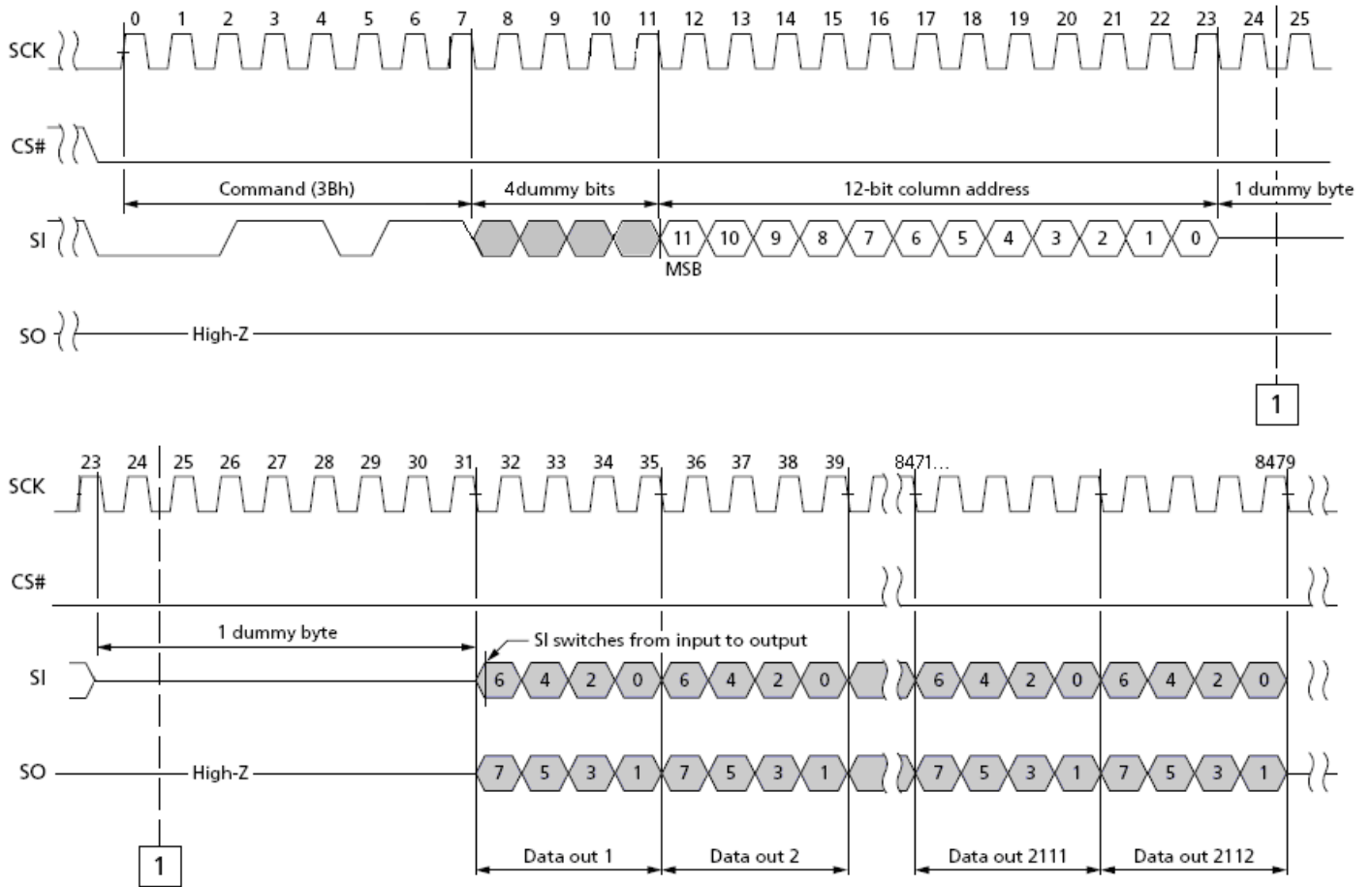

READ FROM CACHE x2 with 4-Byte Address (3Ch) Timing

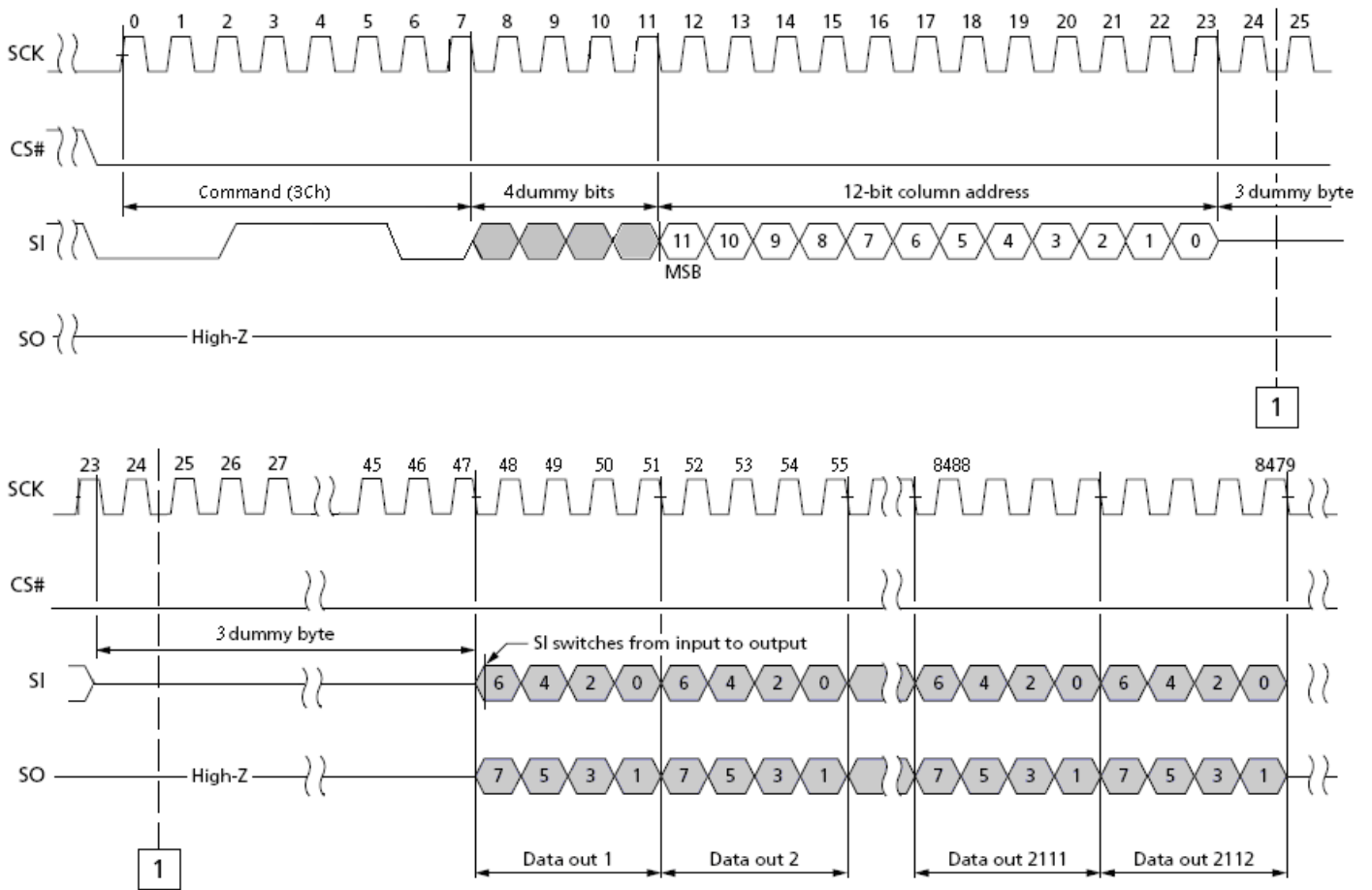

READ FROM CACHE x4 (6Bh) Timing

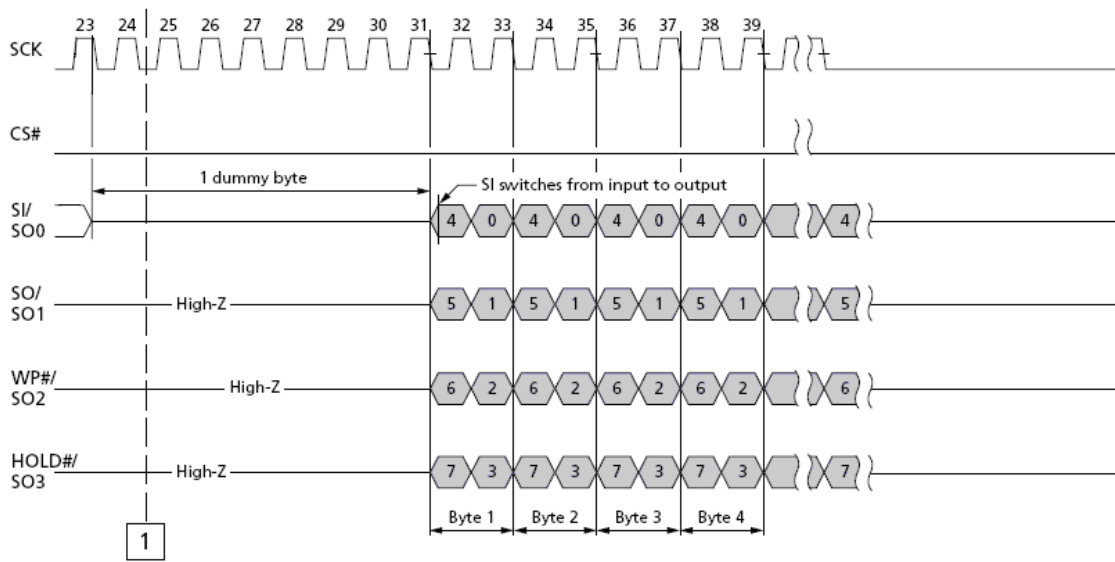
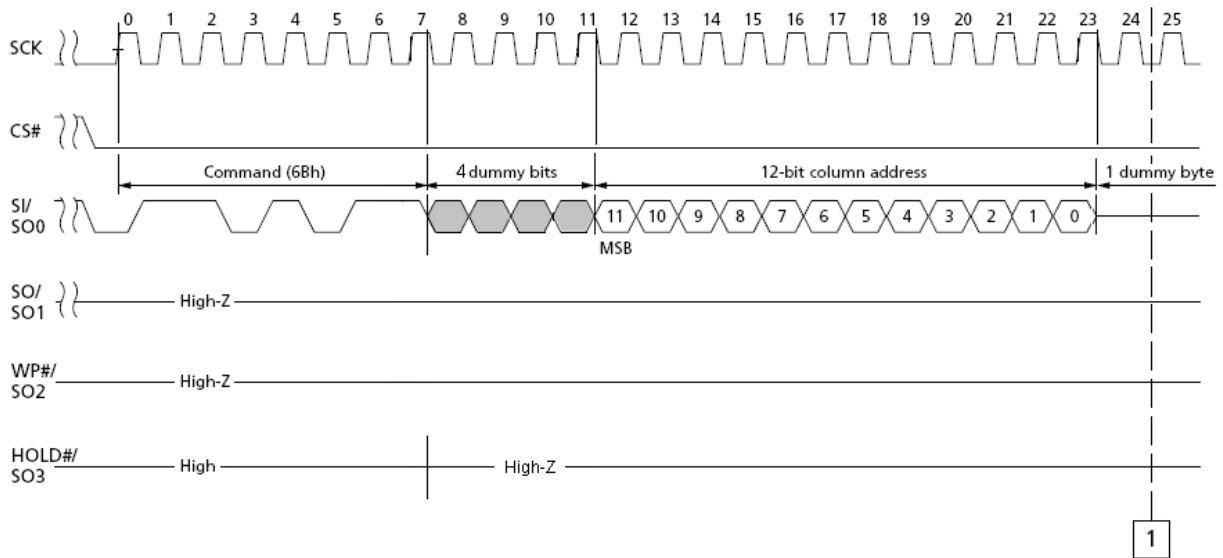

READ FROM CACHE x4 with 4-Byte Address (6Ch) Timing

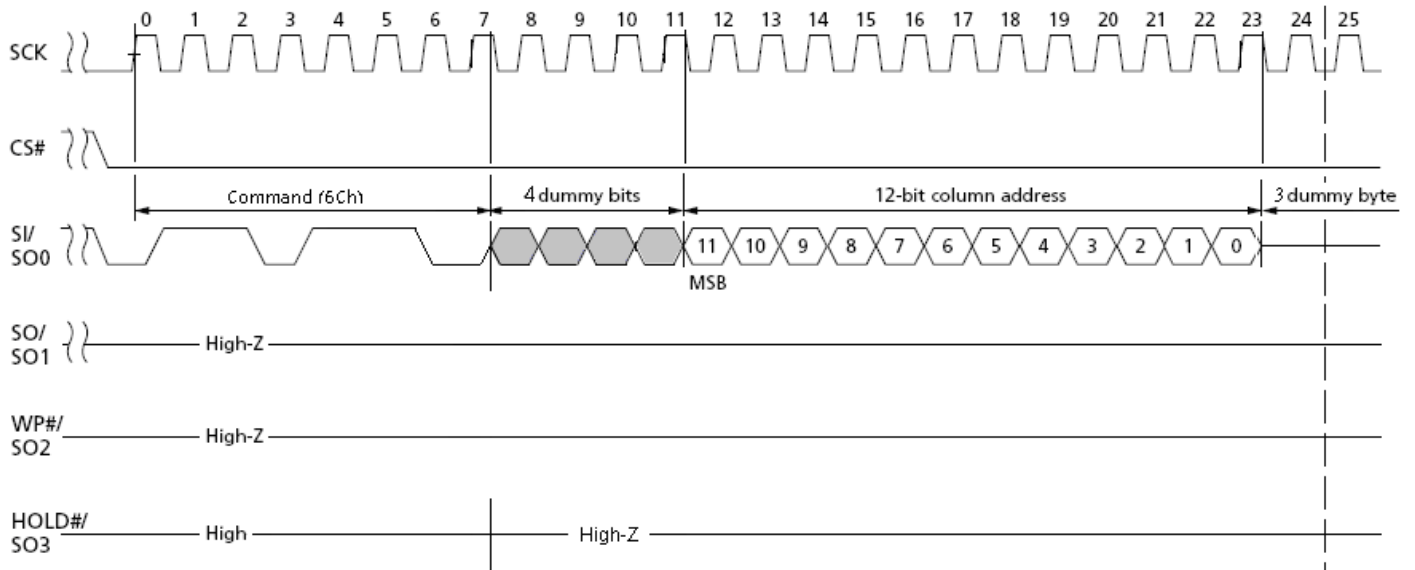

1

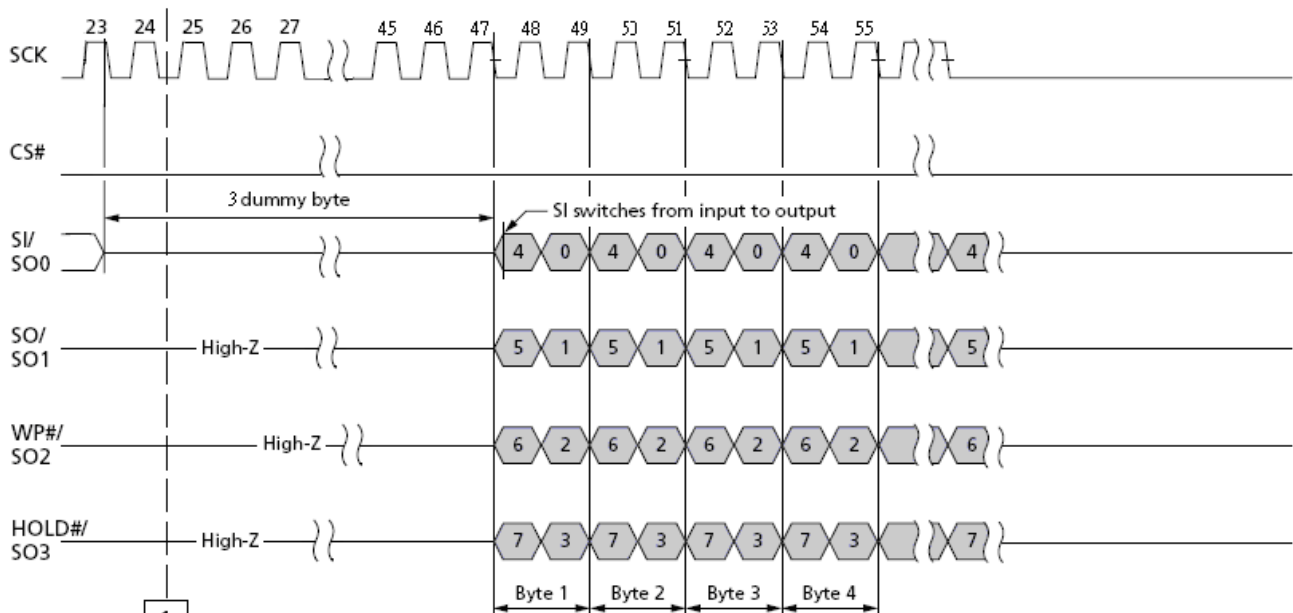

1

Fast Read X2 IO (BBh) Timing

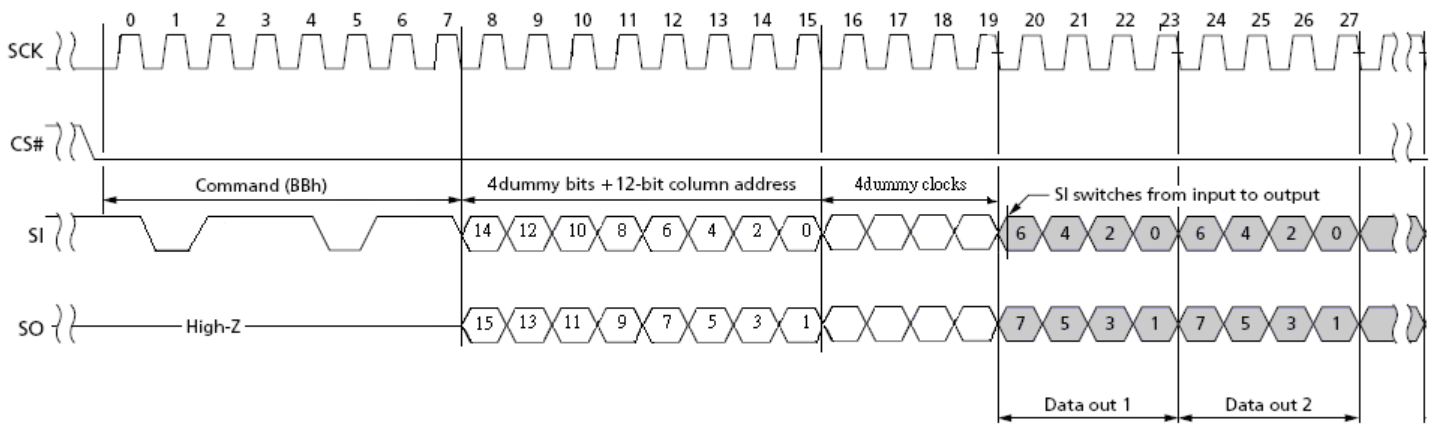

Fast Read X2 IO with 4Byte Address (BCh) Timing

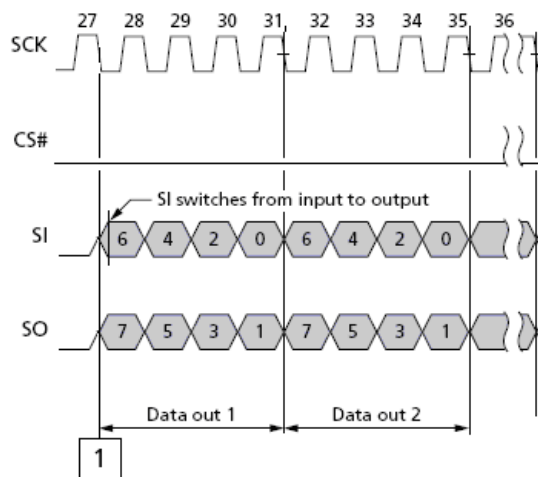
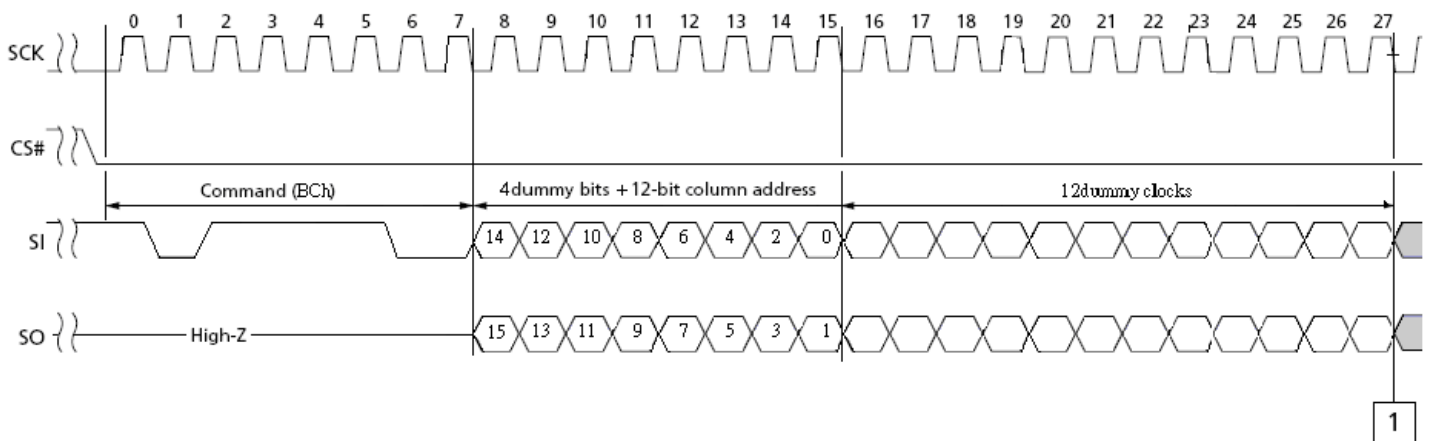

Fast Read X4IO (EBh) Timing

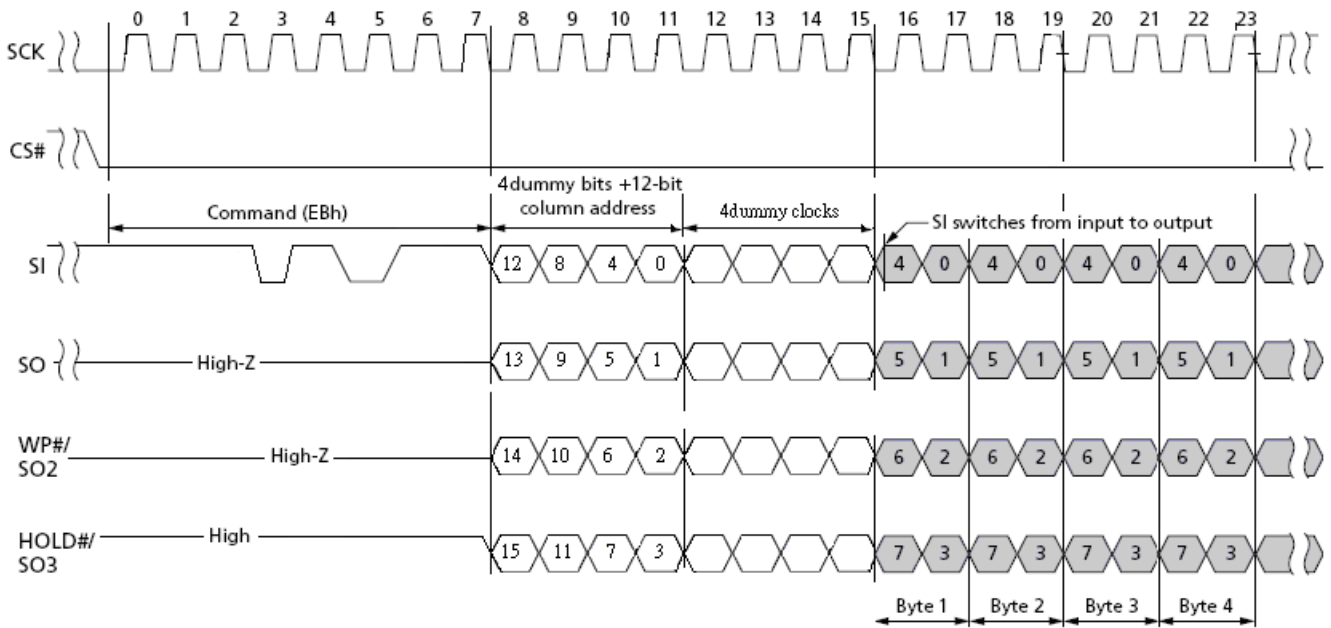

Fast Read X4IO with 4Byte Address (ECh) Timing

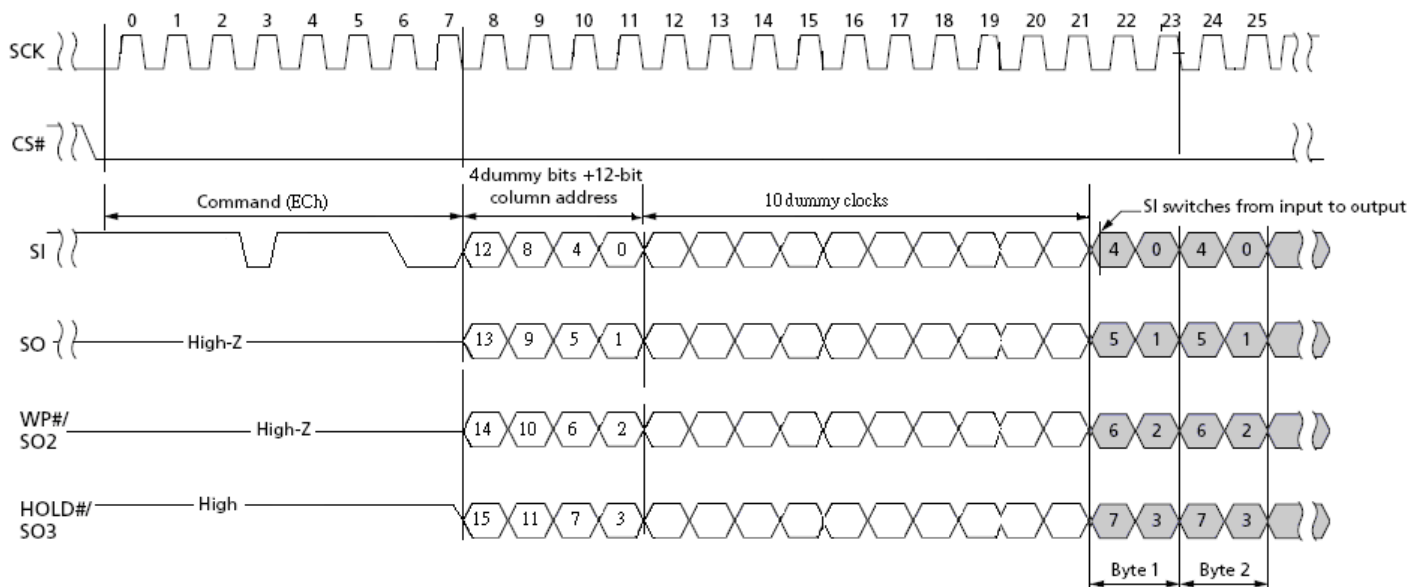

Program Operations and Serial Input

Page Program

The command sequence is follows:

- 06h (WRITE ENABLE)
- 02h (PROGRAM LOAD x1) / 32h (x4)
- 10h (PROGRAM EXECUTE)
- 0Fh (GET FEATURE command to read the status)

The page program operation sequence programs 1 byte to 2112 bytes of data within a page. If WRITE ENABLE command is not issued (WEL bit is not set), then the rest of the program sequence is ignored. PROGRAM LOAD command requires 16-bit address with 4 dummy and a 12-bit column address, then the data bytes to be loaded into cache register. Only four partial page programs are allowed on a single page. If more than 2112 bytes are loaded, then those additional bytes are ignored by the cache register.

After the data is loaded, PROGRAM EXECUTE command must be issued to transfer the data from cache register to main array, and is busy for t_{PROG} time. PROGRAM EXECUTE command requires 24-bit address with 8 dummy bits and a 16-bit row address.

PROGRAM LOAD (02h) Timing

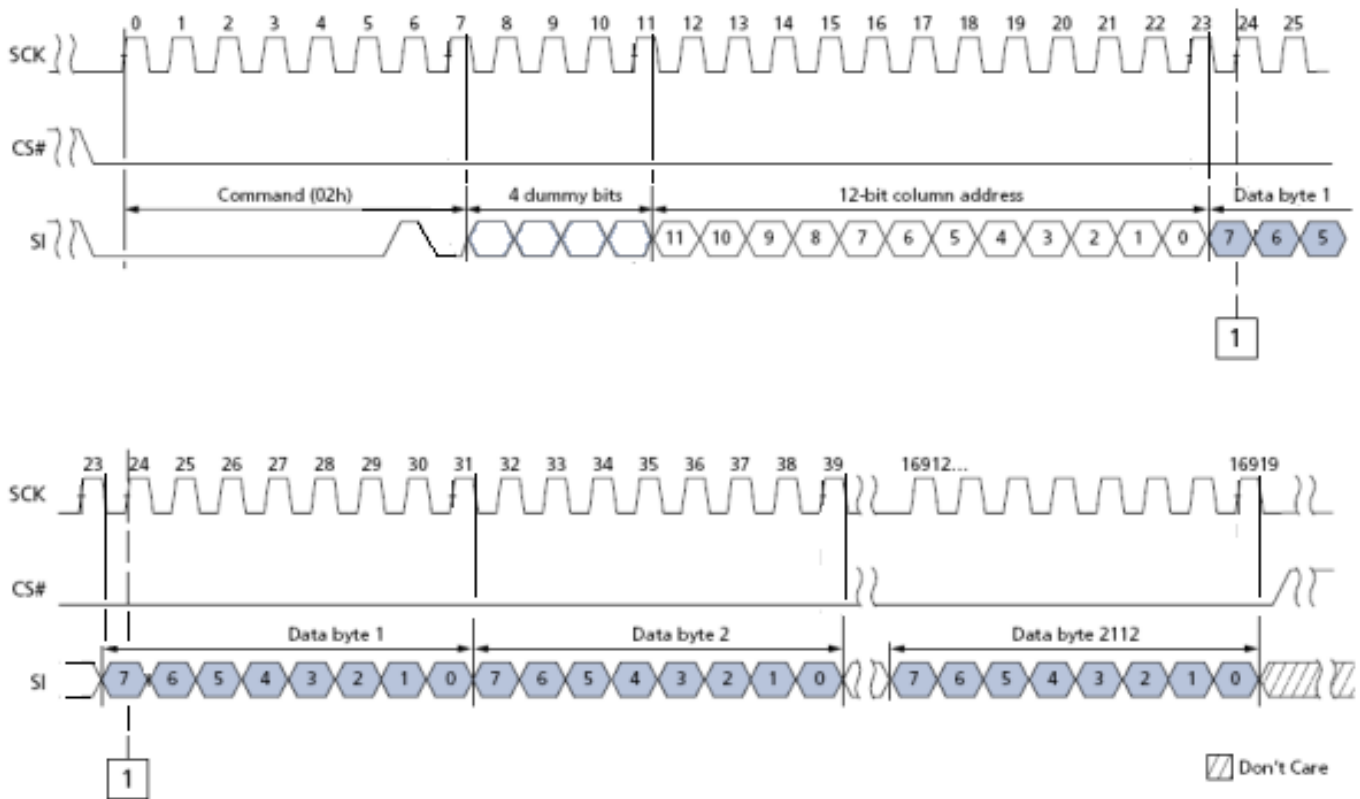

PROGRAM LOAD x4 (32h) Timing

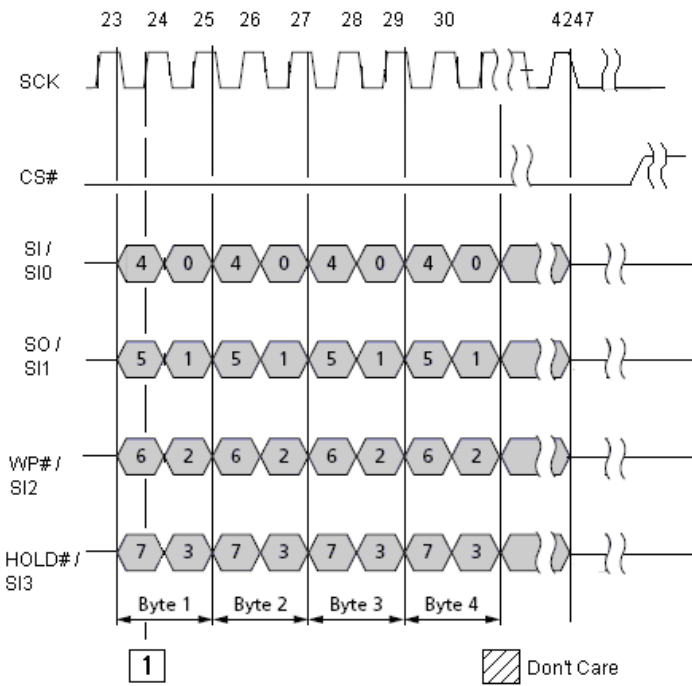
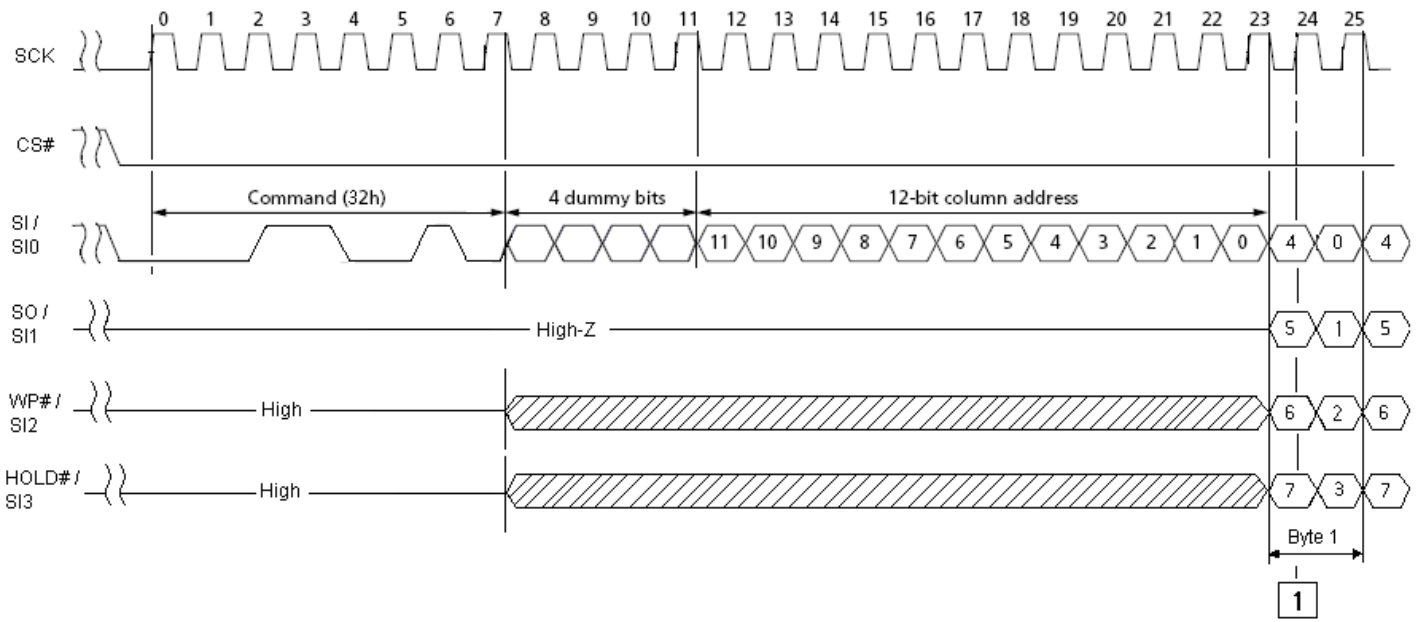

PROGRAM EXECUTE (10h) Timing

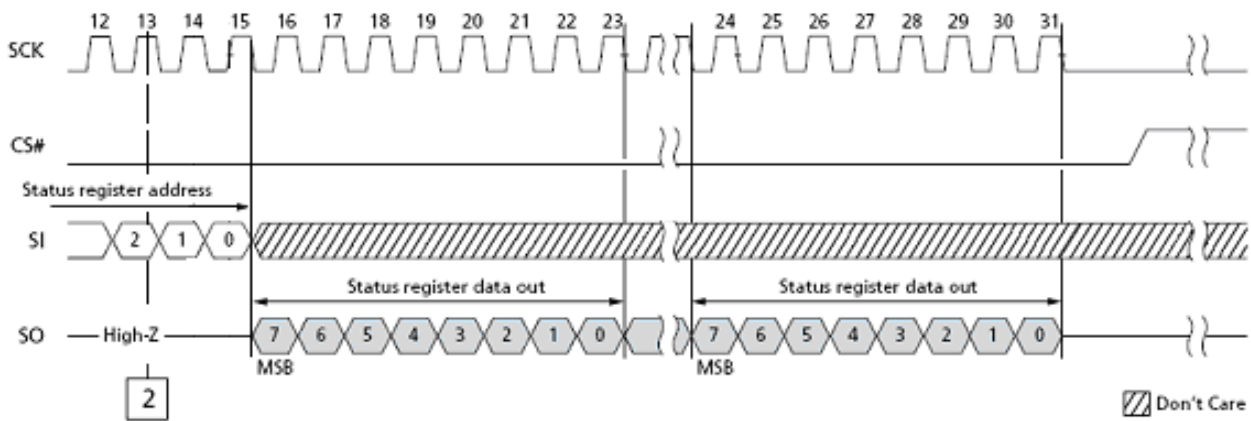
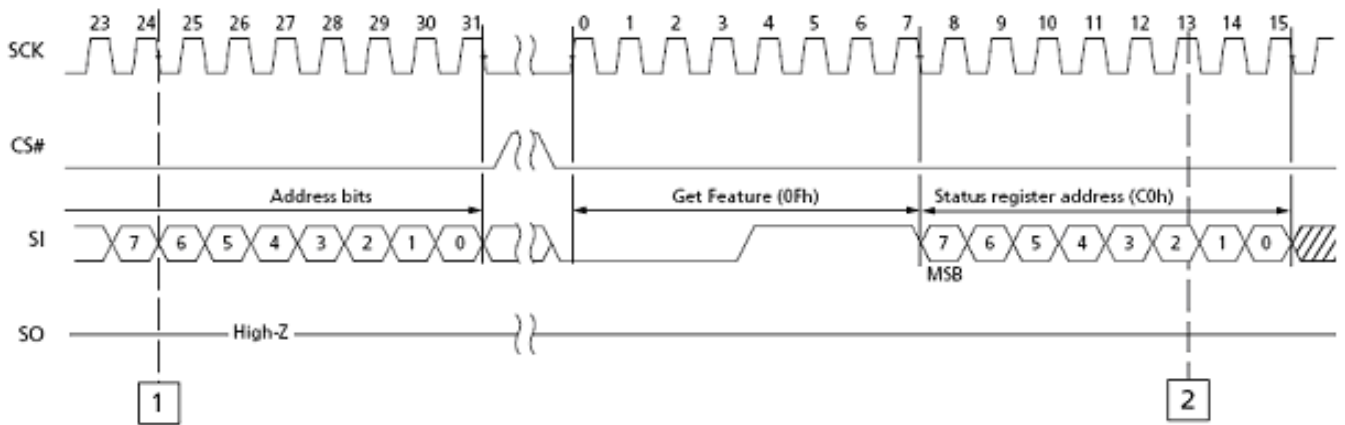
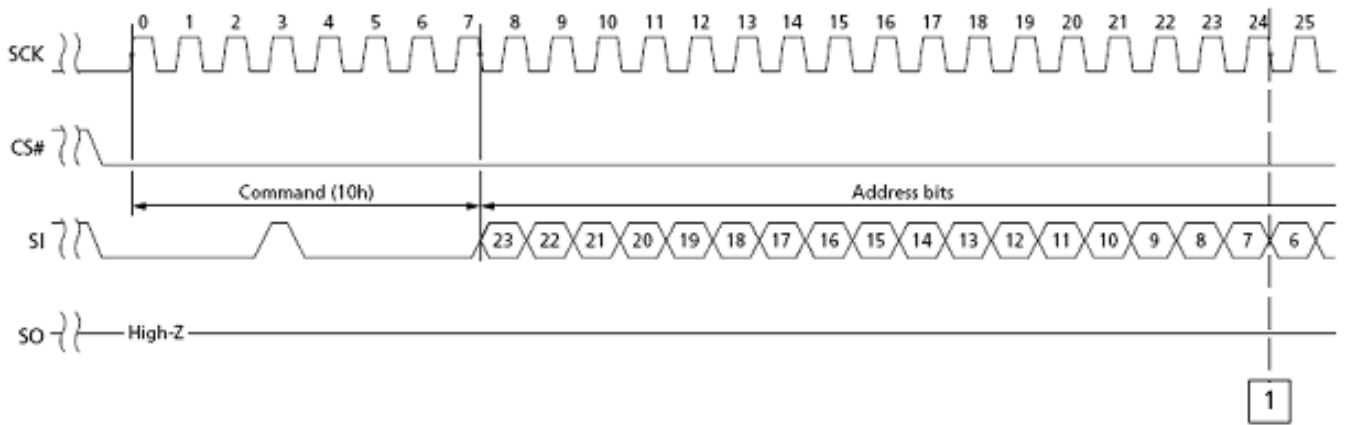

Random Data Program

The command sequence is follows:

- 06h (WRITE ENABLE)
- 84h (PROGRAM LOAD RANDOM DATA x1) / 34h (x4)
- 10h (PROGRAM EXECUTE)
- 0Fh (GET FEATURE command to read the status)

The random data program operation sequence programs or replaces data in a page with existing data. PROGRAM LOAD RANDOM DATA command requires 16-bit address with 4 dummy bits and a 12-bit column address. New data is loaded in the column address provided. If the random data is not sequential, then another PROGRAM LOAD RANDOM DATA command must be issued with a new column address. After the data is loaded, PROGRAM EXECUTE command can be issued to start the programming operation.

PROGRAM LOAD RANDOM DATA (84h) Timing

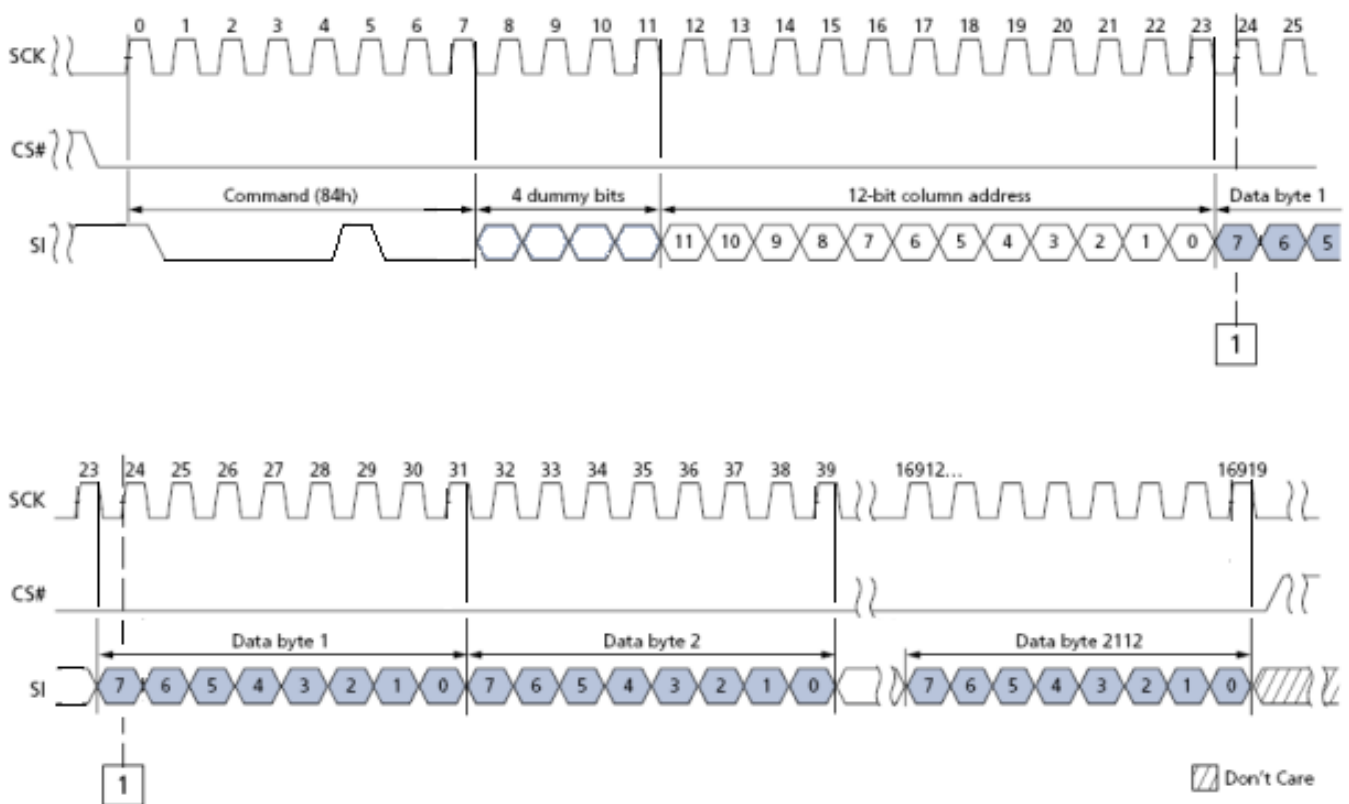

PROGRAM LOAD RANDOM DATA x4 (34h) Timing

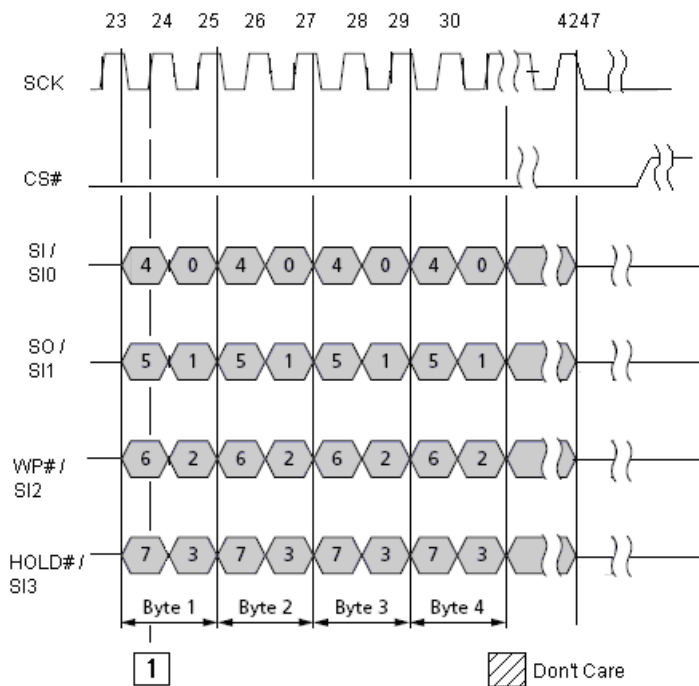
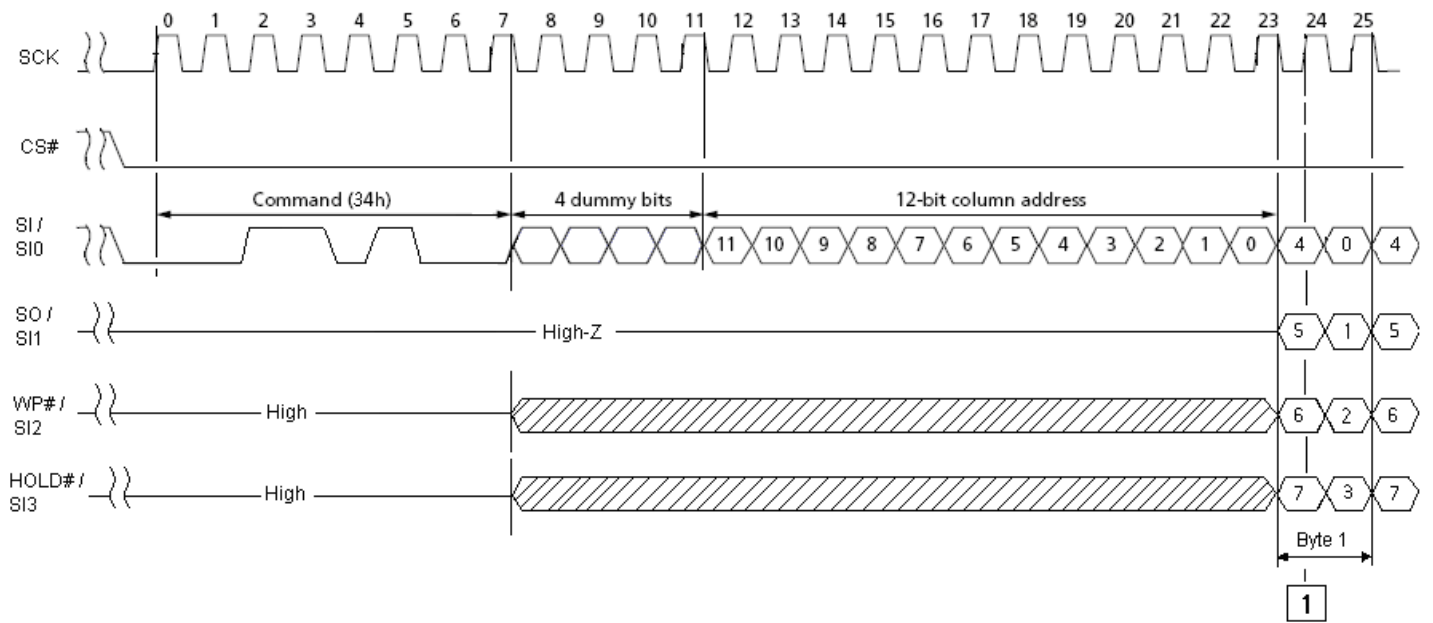

Serial Input and t_{CSCL} Timing

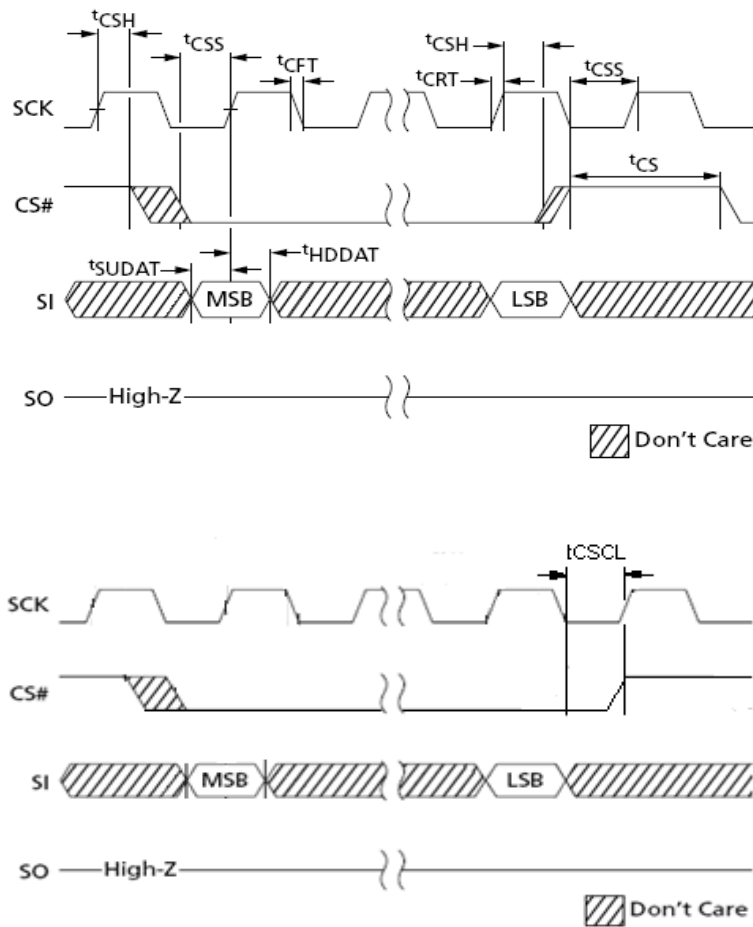

Internal Data Move

The command sequence is follows:

- 13h (PAGE READ to cache)
- 06h (WRITE ENABLE)
- 84h (PROGRAM LOAD RANDOM DATA x1) / 34h (x4); this is OPTIONAL in sequence.
- 10h (PROGRAM EXECUTE)
- 0Fh (GET FEATURE command to read the status)

The INTERNAL DATA MOVE operation sequence programs or replaces data in a page with existing data. Prior to performing an INTERNAL DATA MOVE operation, the target page content must be read into the cache register. PAGE READ command must be followed with a WRITE ENABLE command to change the contents of memory array.

Erase Operation

The command sequence is follows:

- 06h (WRITE ENABLE)
- D8h (BLOCK ERASE)
- 0Fh (GET FEATURE command to read the status)

BLOCK ERASE command requires 24-bit address with 8 dummy bits and a 16-bit row address. If WRITE ENABLE command is not issued (WEL bit is not set), then the rest of the erase sequence is ignored. After the row address is registered, the control logic automatically controls the timing and the erase-verify operations, and the device is busy for t_{BERS} time. BLOCK ERASE command operates on one block at a time.

BLOCK ERASE (D8h) Timing

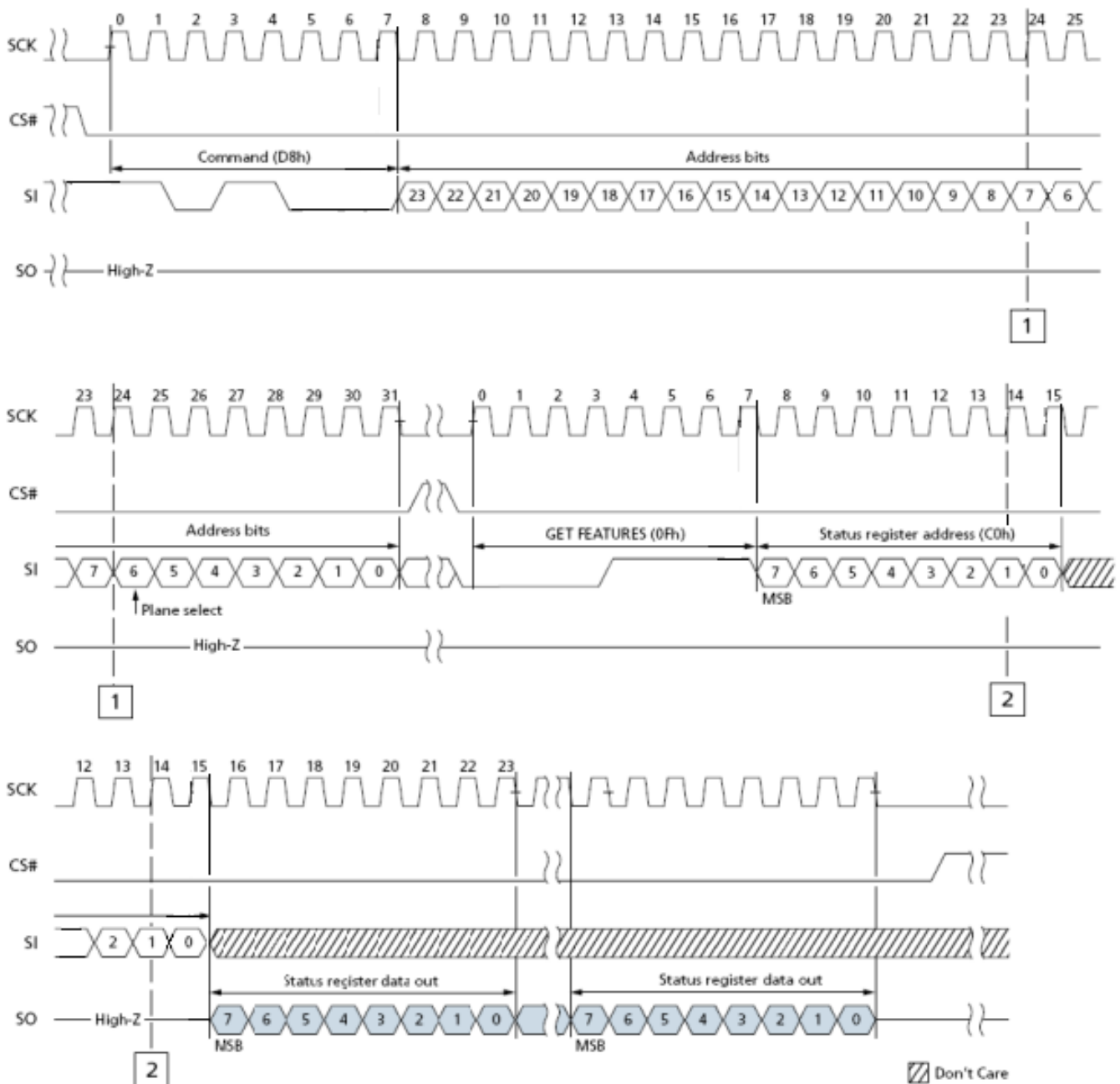

Read ID

The device contains a product identification mode, initiated by writing 9Fh to the command register, followed by an address input of 00h. Five read cycles sequentially output the manufacturer code (C8h), and the device code and 3rd, 4th, 5th cycle ID respectively. The command register remains in Read ID mode until further commands are issued to it.

READ ID Timing

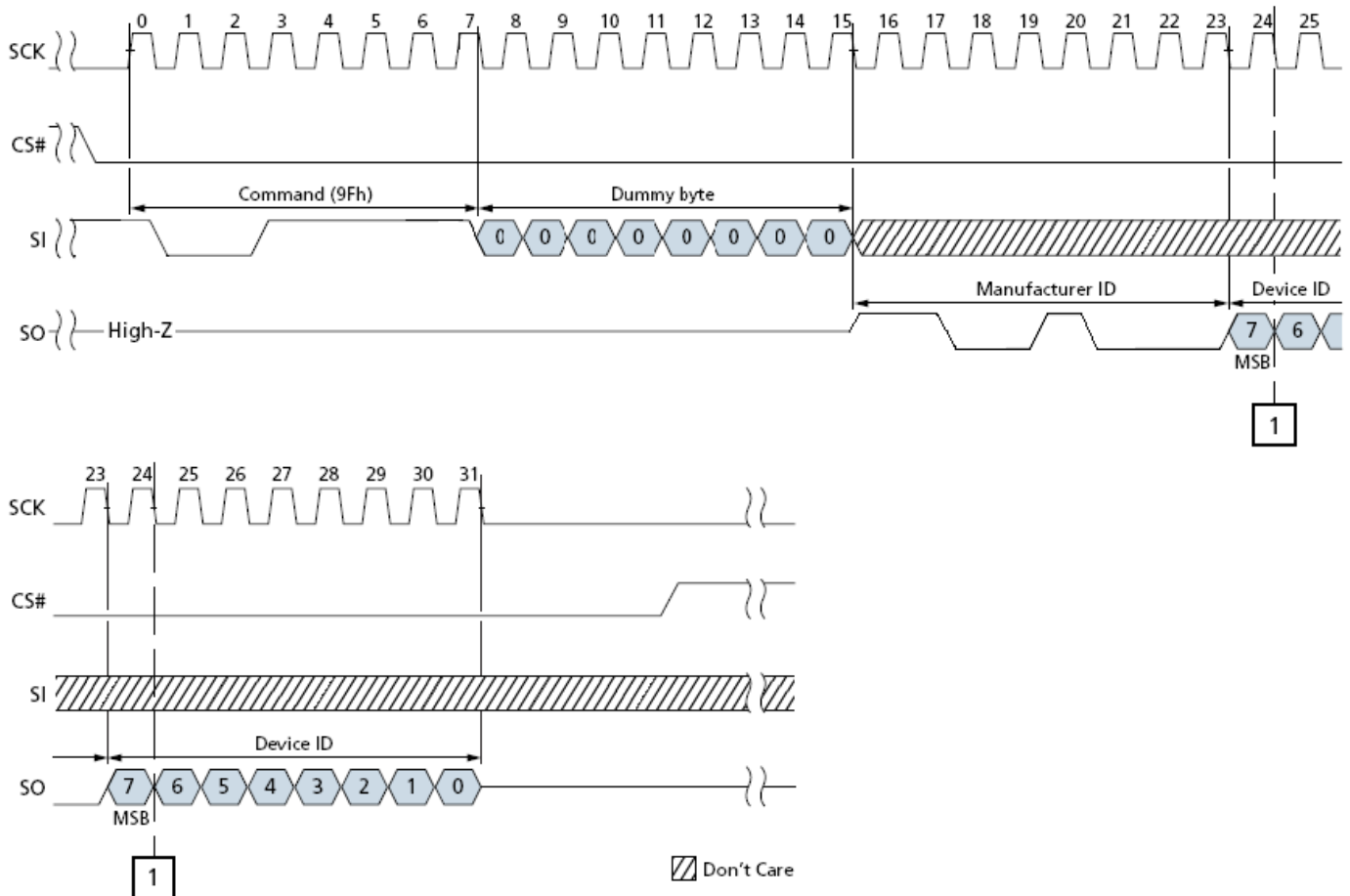

ID Definition Table

Product ID	1 st Cycle (Maker Code)	2 nd Cycle (Device Code)	3 rd Cycle	4 th Cycle	5 th Cycle
F50L2G41LB (2M)	C8h	0Ah	7Fh	7Fh	7Fh

	Description
1 st Byte	Maker Code
2 nd Byte	Device Code
3 rd Byte	JEDEC Maker Code Continuation Code, 7Fh
4 th Byte	JEDEC Maker Code Continuation Code, 7Fh
5 th Byte	JEDEC Maker Code Continuation Code, 7Fh

WP# Timing

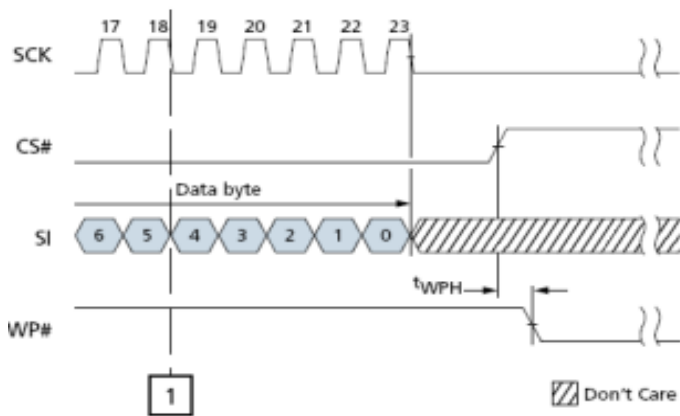
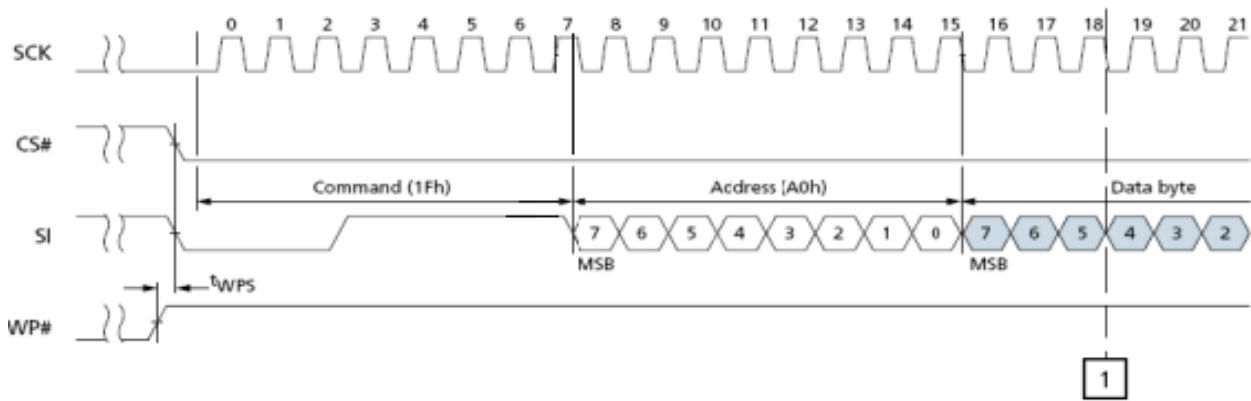

HOLD# Timing

HOLD# input provides a method to pause serial communication with the device but doesn't terminate any READ, PROGRAM, or ERASE operation currently in progress.

Hold mode starts at the falling edge of HOLD# provided SCK is also Low. If SCK is High when HOLD# goes Low, hold mode begins after the next falling edge of SCK. Similarly, hold mode is exited at the rising edge of HOLD# provided SCK is also Low. If SCK is High, hold mode ends after the next falling edge of SCK.

During hold mode, SO is Hi-Z, and SI and SCK inputs are ignored.

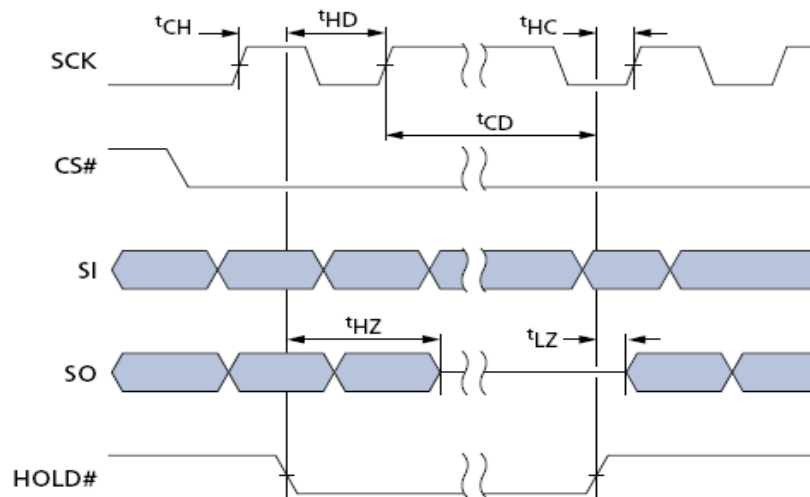

Power-Up

During power transitions, V_{CC} is internally monitored. 250 μ s after V_{CC} has reached 2.5V, WP# is taken High, the device automatically performs the RESET command. The first access to the SPI NAND device can occur 1ms after WP# goes High, and then CS# can be driven Low, SCK can start, and the required command can be issued to the device.

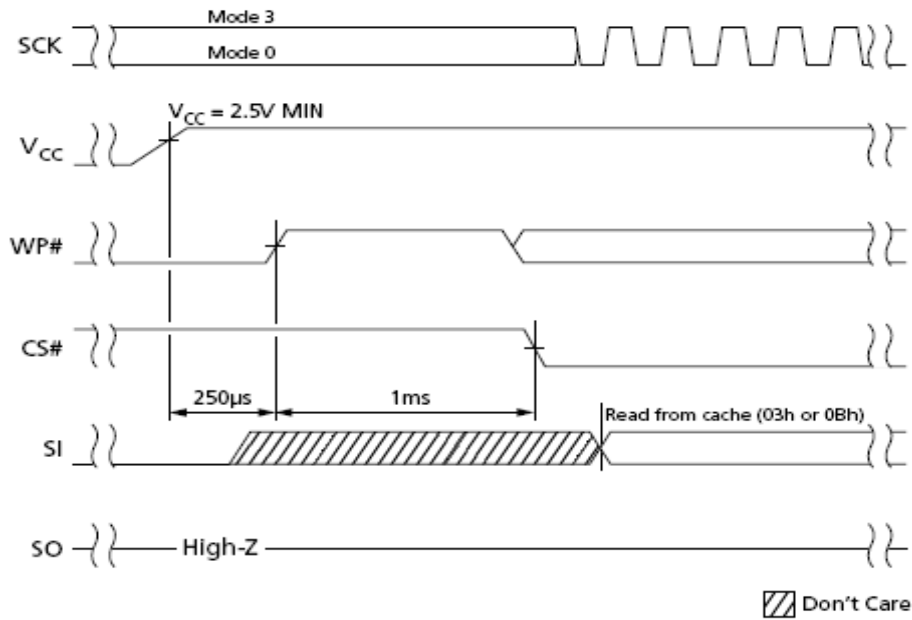
Power-Up and RESET Timing

Read Unique ID Page / Read Parameter Page / OTP Operations

In addition to the main memory array, the device is also equipped with one Unique ID Page, and twenty-eight One-Time-Programmable Pages. The Unique ID Page contains 16 identical copies of the 32-Byte data. The Parameter Page contains 3 identical copies of the 256-Byte data. Both pages are Read only.

This flash device also offers one-time programmable memory area. 28 full pages of OTP data are available on the device, and the entire range is guaranteed to be good. The OTP area is accessible only through the OTP commands. Regarding OTP Read, Read Unique ID Page, and Read Parameter Page, please refer to the specific Page addresses defined in OTP Area Details Table.

The OTP area leaves the factory in an unwritten state. The OTP area cannot be erased, whether it is protected or not. Protecting the OTP area prevents further programming of that area. It means the OTP area becomes read-only after being locked.

The OTP area is only accessible while the OTP enable bit is set to 1. To set the device to OTP operation mode, issue the Set Feature (1Fh) command. When the device is in OTP operation mode, subsequent Read and/or Page Program (both X1 and X4) are applied to the OTP area. Please refer to relative command sequences defined in datasheet. When you want to come back to normal operation, you need to set OTP enable bit to 0. Otherwise, device will stay in OTP mode.

OTP/ Read / Read Unique ID / Read Parameter Page:

- Issue the Set Feature (1Fh) command.
- Issue the feature address (B0h).
- Set the OTP enable bit to 1.
- Issue the Page Read (13h) command with a specific Page address.

OTP Program:

- Issue the Set Feature (1Fh) command.
- Issue the feature address (A0h).
- Set Protection bit to 0.
- Issue the feature address (B0h).
- Set the OTP enable bit to 1.
- Issue the Write Enable (06h) command.
- Issue the Program Load (02h) and Program Execute (10h) commands.

OTP Lock:

- Issue the Set Feature (1Fh) command.
- Issue the feature address (A0h).
- Set Protection bit to 0.
- Issue the feature address (B0h).
- Set both the OTP enable and OTP protect bits to 1.
- Issue the Write Enable (06h) command.
- Issue the Program Execute (10h) command.

OTP Modes and Commands Table

		Set Feature
OTP Operation mode	Read	1Fh - B0h ⁽¹⁾ - 40h or 50h ⁽²⁾
	Page Program	1Fh - B0h - 40h or 50h
OTP Protection mode	Program Protect	1Fh - B0h - C0h or D0h
OTP Release mode	Leave OTP mode	1Fh - B0h - 00h or 10h

NOTE:

1. B0h is Configuration Register address.
2. 50h, D0h, and 10h are Configuration Register data values as ECC enabled.

OTP Area Details Table

Item	Value	Description	Data Length
Unique ID Page address	00h	Factory programmed, Read only	32-Byte x 16
Parameter Page address	01h	Factory programmed, Read only	256-Byte x 3
Number of OTP pages	28	One Time Program and OTP lockable	2112-Byte
OTP page address	02h – 1Dh	One Time Program and OTP lockable	2112-Byte
Number of partial page programs for each page in the OTP area	1	One Time Program and OTP lockable	2112-Byte

Parameter Page Data Table

Byte	Description	Value
0-3	Parameter page signature ("O", "N", "F", "I")	4Fh, 4Eh, 46h, 49h
4-5	Revision number	00h, 00h
6-7	Features supported	00h, 00h
8-9	Optional commands supported	2Ch, 00h
10-31	Reserved	All 00h
32-43	Device manufacturer	50h, 4Fh, 57h, 45h, 52h, 43h, 48h, 49h, 50h, 20h, 20h, 20h
44-63	Device model	50h, 53h, 55h, 32h, 47h, 53h, 32h, 30h, 44h, 58h, 20h, 20h, 20h, 20h, 20h, 20h, 20h, 20h, 20h, 20h
64	Manufacturer ID	C8h
65-66	Date code	00h, 00h
67-79	Reserved	All 00h
80-83	Number of data bytes per page	00h, 08h, 00h, 00h
84-85	Number of spare bytes per page	40h, 00h
86-91	Reserved	All 00h
92-95	Number of pages per block	40h, 00h, 00h, 00h
96-99	Number of blocks per unit	00h, 04h, 00h, 00h
100	Number of logical units	01h
101	Number of address cycles	00h
102	Number of bits per cell	01h
103-104	Number of maximum bad blocks per unit	14h, 00h
105-106	Block endurance	01h, 05h
107	Guaranteed valid blocks at beginning of target	01h
108-109	Block endurance of guaranteed valid blocks	00h, 00h
110	Number of partial programs per page	04h
111	Reserved	00h
112	Number of bits ECC	00h
113	Number of Interleaved address bits	00h
114	Interleaved operation attributes	00h
115-127	Reserved	All 00h
128	I/O pin capacitance	08h

129-132	Reserved	All 00h
133-134	tPROG (max)	84h, 03h
135-136	tBERS (max)	10h, 27h
137-138	tR (max)	64h, 00h
139-163	Reserved	All 00h
164-165	Vendor-specific revision number	00h, 00h
166-253	Reserved	All 00h
254-255	Integrity CRC	Set at test
256-511	Values of bytes 0-255	Values of bytes 0-255
512-767	Values of bytes 0-255	Values of bytes 0-255
768+	Additional redundant parameter pages	

PACKING DIMENSIONS

8-Contact WSON (8x6 mm)

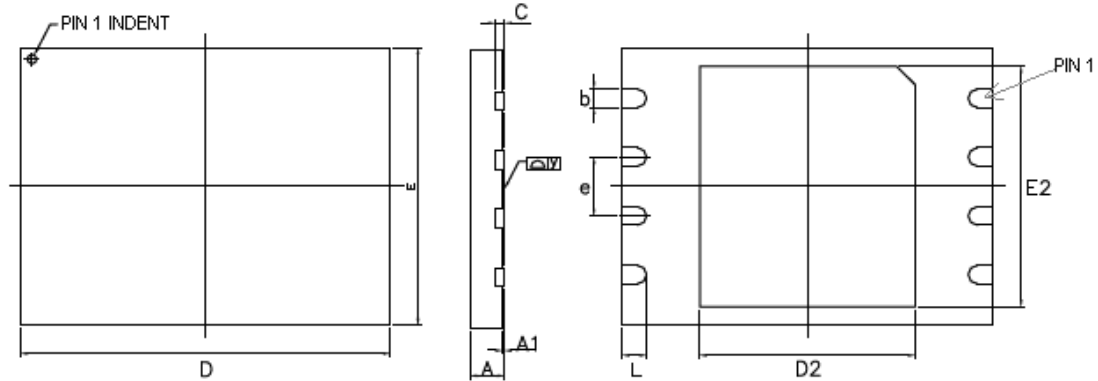

SYMBOL	MILLIMETERS			INCHES		
	Min	Normal	Max	Min	Normal	Max
A	0.70	0.75	0.8	0.028	0.03	0.031
A1	0.00	0.035	0.05	0.000	0.001	0.002
b	0.35	0.40	0.45	0.014	0.016	0.018
C	0.19	0.20	0.25	0.007	0.008	0.010
D	7.90	8.0	8.10	0.311	0.315	0.319
D2	3.35	3.40	3.45	0.132	0.134	0.136
E	5.90	6.0	6.10	0.232	0.236	0.240
E2	4.25	4.30	4.35	0.167	0.168	0.171
e	1.27BSC			0.05BSC		
L	0.45	0.50	0.55	0.018	0.020	0.022
y	0.00	...	0.08	0.000	...	0.003

NOTE: BSC, Basic lead spacing between centers.

PACKING DIMENSIONS

8-Contact WSON (8x6 mm) without expose metal pad

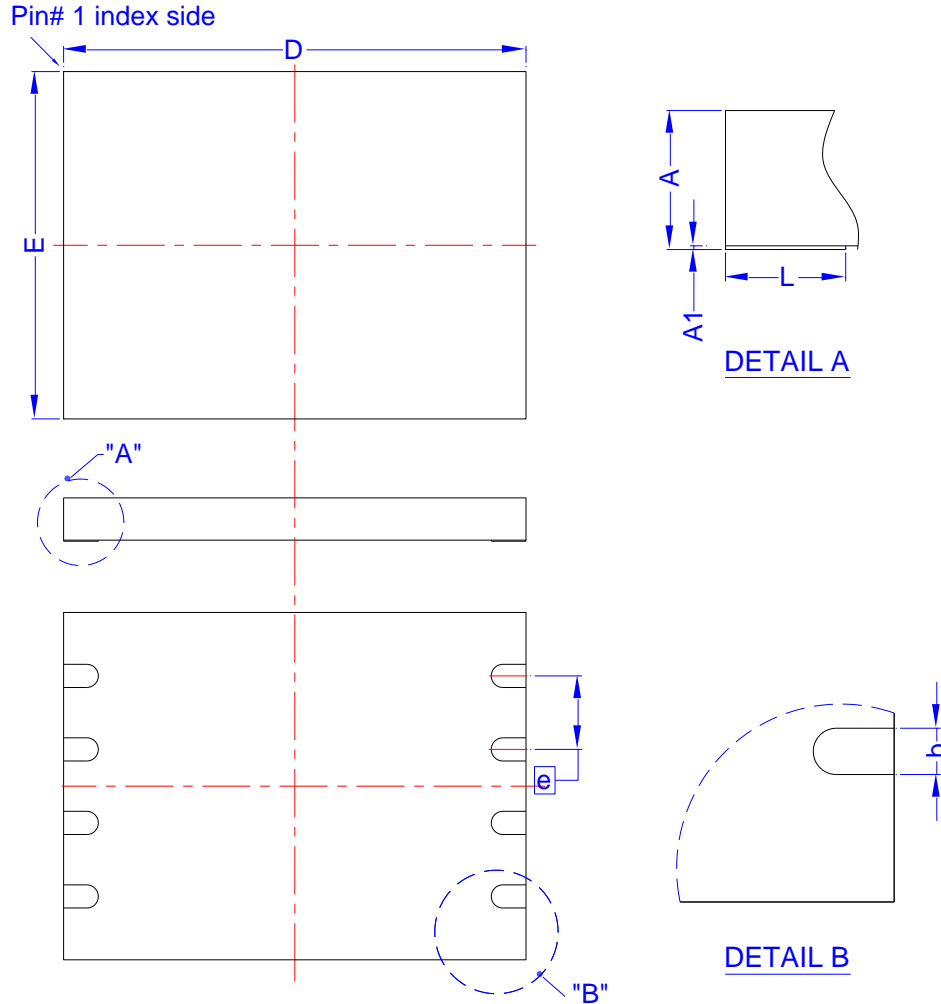

Symbol	Dimension in mm			Dimension in inch		
	Min	Min	Min	Min	Norm	Max
A	0.70	0.75	0.80	0.028	0.030	0.031
A1	0.00	0.02	0.05	0.000	0.001	0.002
b	0.35	0.40	0.45	0.014	0.016	0.018
D	7.90	8.00	8.10	0.311	0.315	0.319
E	5.90	6.00	6.10	0.232	0.236	0.240
e	1.27 BSC			0.050 BSC		
L	0.40	0.50	0.60	0.016	0.020	0.024

Controlling dimension : millimeter
 (Revision date : Apr 25 2018)

Revision History

Revision	Date	Description
0.1	2017.05.05	Original
0.2	2017.08.28	Add Read Unique ID Page / Read Parameter Page / OTP Operations
0.3	2017.12.28	Modify 8-Contact WSON (8x6 mm) PACKING DIMENSIONS
0.4	2018.04.30	Add operating temperature
1.0	2018.07.26	Delete Preliminary
1.1	2018.12.03	Modify the packing dimension of WSON package
1.2	2019.01.31	1. Restore the packing dimension of WSON package 2. Add the product ID and packing dimension of WSON package without expose metal pad

Important Notice

All rights reserved.

No part of this document may be reproduced or duplicated in any form or by any means without the prior permission of ESMT.

The contents contained in this document are believed to be accurate at the time of publication. ESMT assumes no responsibility for any error in this document, and reserves the right to change the products or specification in this document without notice.

The information contained herein is presented only as a guide or examples for the application of our products. No responsibility is assumed by ESMT for any infringement of patents, copyrights, or other intellectual property rights of third parties which may result from its use. No license, either express, implied or otherwise, is granted under any patents, copyrights or other intellectual property rights of ESMT or others.

Any semiconductor devices may have inherently a certain rate of failure. To minimize risks associated with customer's application, adequate design and operating safeguards against injury, damage, or loss from such failure, should be provided by the customer when making application designs.

ESMT's products are not authorized for use in critical applications such as, but not limited to, life support devices or system, where failure or abnormal operation may directly affect human lives or cause physical injury or property damage. If products described here are to be used for such kinds of application, purchaser must do its own quality assurance testing appropriate to such applications.