

# FM51

## Low Voltage High Drive Temperature Sensor

### General Description

The FM51 is a high-precision CMOS temperature sensor that provides a cost-effective solution for applications requiring high-accuracy temperature monitoring. The FM51 is ideally suited for applications requiring high drive current. The FM51 output voltage ramp is extremely linear and has a slope of 10mV/°C. It is typically accurate to ±1°C over a temperature range of -40°C to 125°C and has a typical room temperature accuracy of ±0.5°C. The output voltage characteristic for the FM51 is illustrated in Figure 1.

The FM51 does not require external calibration. Factory calibration of the FM51 is performed using a low-cost trimming technique.

The FM51 is available in 3-pin SOT-23 surface mount packages.

### Features

- Precision Calibrated to ±1°C (Typical)
- Temperature Range: -40°C to 125°C
- Extremely Linear Output Ramp (10mV/°C)

- Low Output Impedance for 1mA Load
- Output Ramp is Calibrated in Degrees Celsius
- Low Operating Current <130µA (no load)
- Low Self Heating (0.2°C Max in Still Air)
- Operating Voltage Range: +2.7V to +6.0V
- Uses a Single Positive Supply
- Non-linearity ≤ 0.8°C

### Applications

- Computers
- Battery Management
- FAX Machines/Printers/Copiers
- Portable Medical Instruments
- HVAC
- Power Supply Modules
- Disk Drives
- Automotive Control Circuits

### Typical Applications

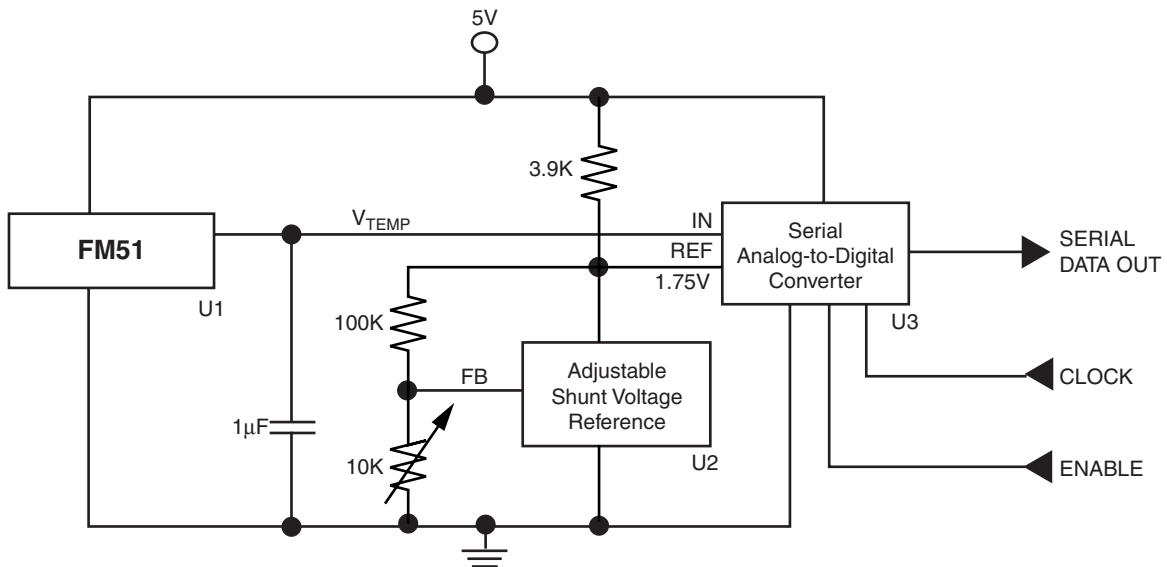

Serial Output Temperature to Digital Converter (Full Scale = +125°C)

Typical Applications (continued)

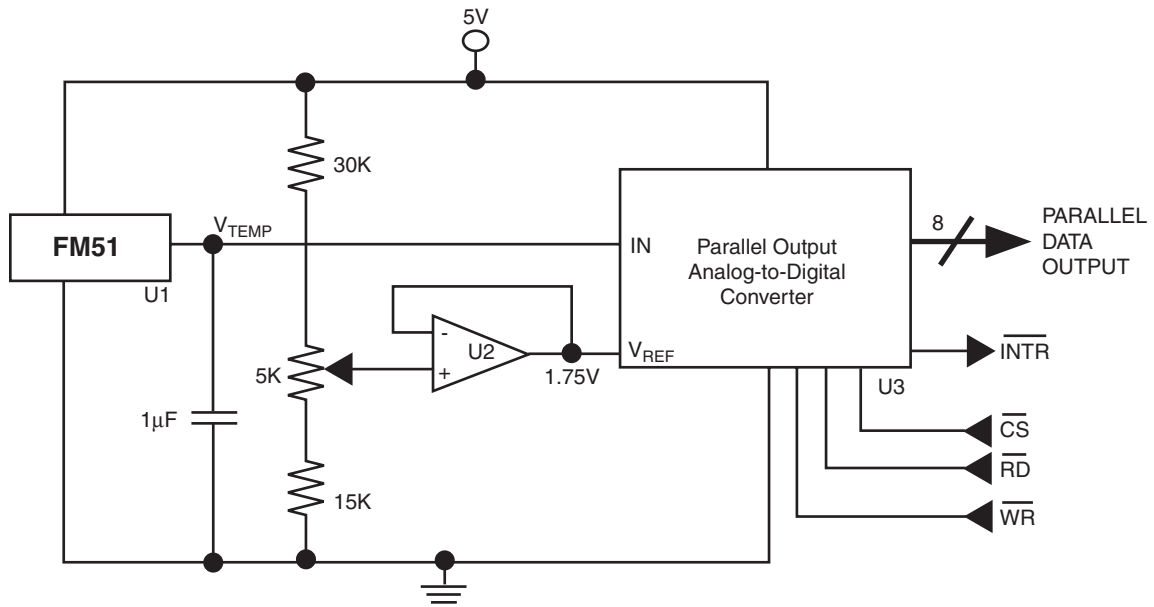

Parallel Output Temperature to Digital Converter (Full Scale = +125°C)

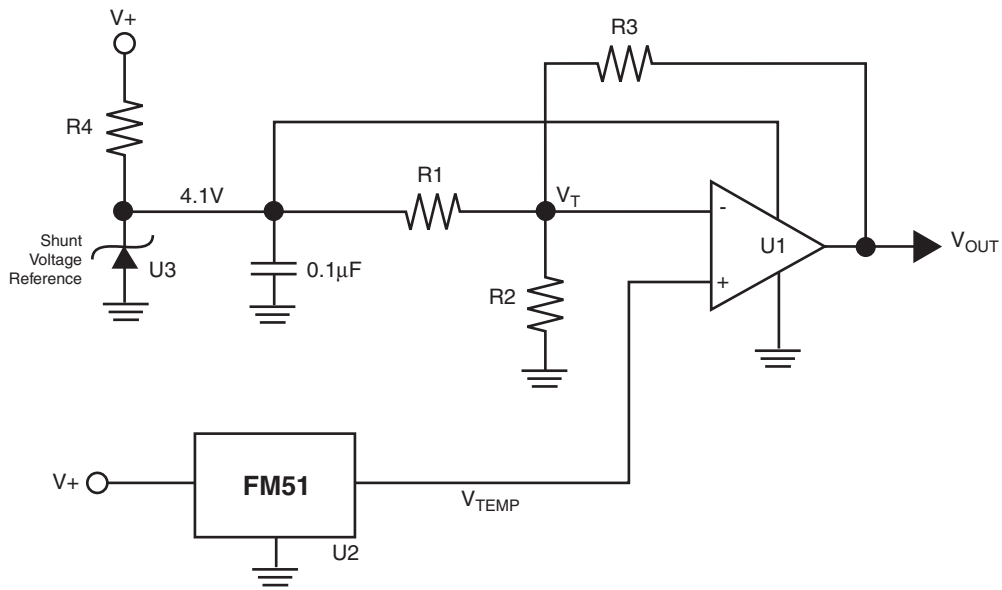

Thermostat/ Fan Controller

## Ordering Information

Part Number	Package	Temperature Range	How Supplied
FM51S3	3-Pin SOT-23	-40°C to +125°C	3000 units on T&R

## Absolute Maximum Ratings (Note 1)

Parameter	Rating	Storage Temperature Range	-60°C to +150°C
Supply Voltage	+7V	Lead Soldering Temperature	220°C
Output Voltage	$V_{DD} + 0.5V$	ESD <sup>3</sup>	
Output Current	10mA	Human Body Model	2000V
		Machine Model	250V
Operating Temperature Range <sup>2</sup>	-50°C to +150°C		

### Notes:

1. Absolute maximum ratings are limits beyond which operation may cause permanent damage to the device. These are stress ratings only; functional operation at or above these limits is not implied.
2. Operating ratings are conditions for which the device is intended to be functional without specific guaranteed performance limits. For guaranteed specifications and test conditions refer to Electrical Characteristics.
3. Human Body Model: 100pF capacitor discharged through a 1.5kOhm resistor into each pin. Machine Model: 200pF capacitor discharged directly into each pin.

## Electrical Characteristics<sup>4</sup>

Limits apply for  $-40^{\circ}\text{C} \leq T_A \leq +125^{\circ}\text{C}$  and  $V_{DD} = +5.0V$  unless otherwise noted.

Parameter	Symbol	Conditions	Min	Typ	Max	Units
Accuracy <sup>5</sup>		$T_A = +25^{\circ}\text{C}$	-1	$\pm 0.5$	+1	°C
		$T_A = -40^{\circ}\text{C} (T_{MIN})$	-3	$\pm 1$	+3	°C
		$T_A = +125^{\circ}\text{C} (T_{MAX})$	-3	$\pm 1$	+3	°C
Non-Linearity <sup>6</sup>			-0.8		+0.8	°C
Supply Voltage	$V_{DD}$		+2.7		+6.0	V
Supply Current	$I_S$	Output floating; $T_A = +25^{\circ}\text{C}$			130	$\mu\text{A}$
Output Sink Capability	$I_{OL}$	$+2.7V < V_{DD} < +6.0V$		1		mA
Output Source Capability	$I_{OH}$	$+2.7V < V_{DD} < +6.0V$		1		mA
Average Output Slope (Sensor Gain)	$A_{OUT}$		9.2	10	10.2	$\text{mV}/^{\circ}\text{C}$
Output Load Current Capabilities	$I_L$		-1		+10	mA
Room Temperature Output	$V_{OUT25}$	$T_A = +25^{\circ}\text{C}$	740		760	mV

### Notes:

4. These specifications are guaranteed only for the test conditions listed.
5. Accuracy (expressed in °C) = Difference between calculated output voltage and measured output voltage. Calculated output voltage =  $10\text{mV}/^{\circ}\text{C}$  multiplied by the device's case temperature at specified conditions of temperature, voltage and power supply, added to 500mV.
6. Non-linearity is defined as the deviation of the output-voltage-versus-temperature curve from the best-fit straight line, over the device's rated temperature range.

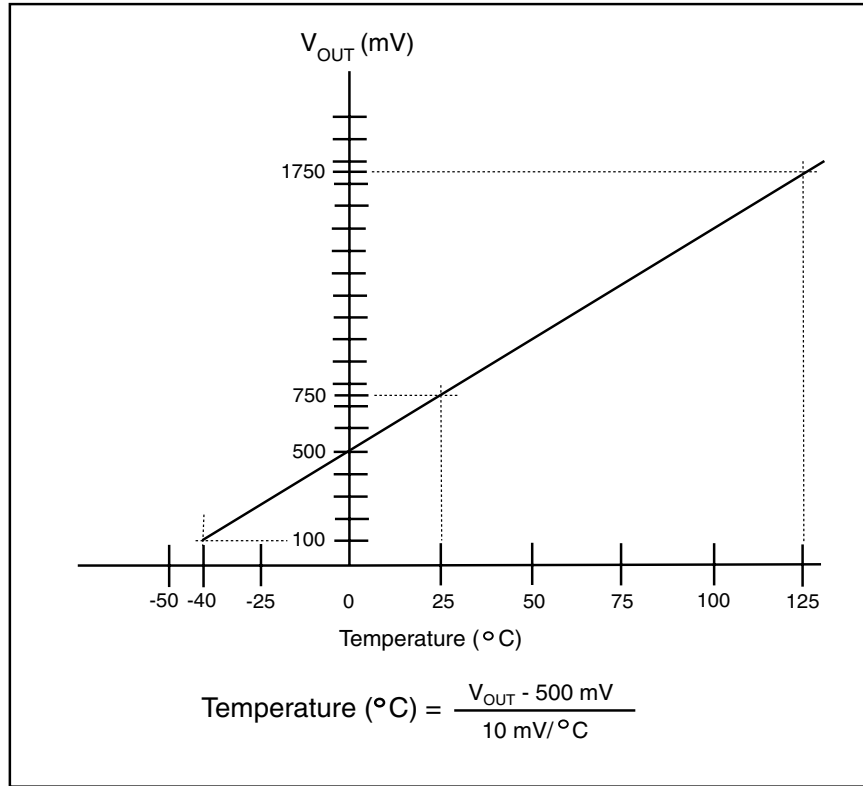

**Figure 1. FM51 Output Voltage vs. Temperature**

## Mounting

The FM51 can be easily mounted by gluing or cementing it to a surface. In this case, its temperature will be within about 0.2°C of the temperature of the surface it is attached to if the ambient air temperature is almost the same as the surface temperature. If the air temperature is much higher or lower than the surface temperature, the actual temperature of the FM51 die will be at an intermediate temperature between the surface temperature and the air temperature.

To ensure good thermal conductivity, the backside of the FM51 die is directly attached to the GND pin. The lands and traces to the FM51 will, of course, be part of the printed circuit board, which is the object whose temperature is being measured. These printed

circuit board lands and traces will not cause the FM51's temperature to deviate from the desired temperature.

Alternatively, the FM51 can be mounted inside a sealed-end metal tube, and can then be dipped into a bath or screwed into a threaded hole in a tank. As with any IC, the FM51 and accompanying wiring and circuits must be kept insulated and dry to avoid leakage and corrosion. This is especially true if the circuit may operate at cold temperatures where condensation can occur. Printed-circuit coatings and varnishes such as Humiseal and epoxy paint or dips can be used to ensure that moisture cannot corrode the FM51 or its connections.

Typical Performance Characteristics

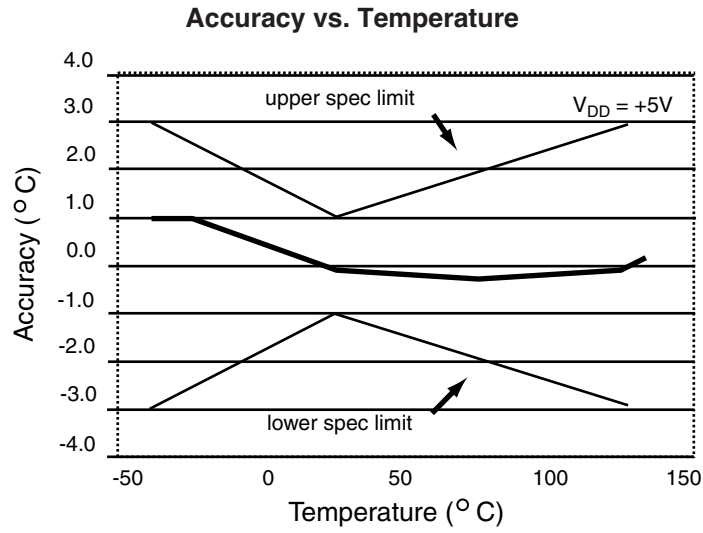

Pin Configuration

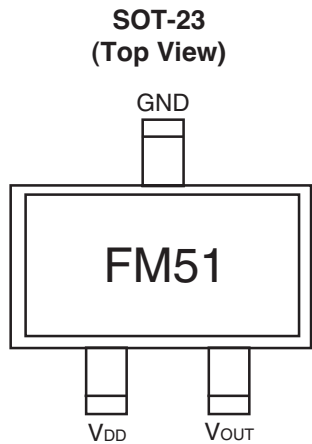

Application Diagram

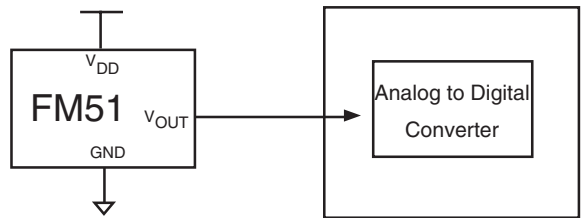

**Physical Dimensions** inches (millimeters) unless otherwise noted

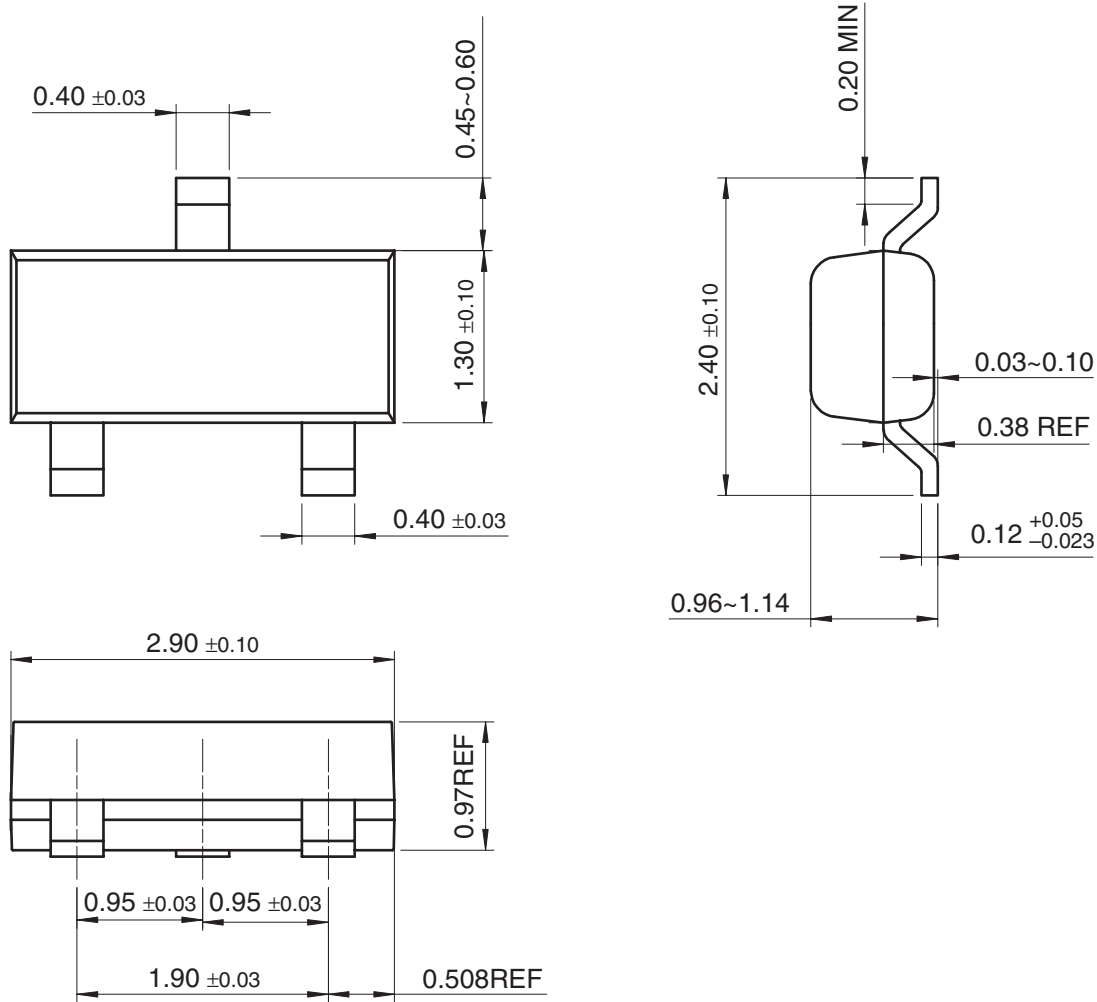

**SOT-23 Package Dimensions  
FS Package Code AU**

**Life Support Policy**

Fairchild's products are not authorized for use as critical components in life support devices or systems without the express written approval of the President of Fairchild Semiconductor Corporation. As used herein:

1. Life support devices or systems are devices or systems which, (a) are intended for surgical implant into the body, or (b) support or sustain life, and whose failure to perform, when properly used in accordance with instructions for use provided in the labeling, can be reasonably expected to result in a significant injury to the user.
2. A critical component is any component of a life support device or system whose failure to perform can be reasonably expected to cause the failure of the life support device or system, or to affect its safety or effectiveness.

**Fairchild Semiconductor  
Americas  
Customer Response Center**  
Tel: 1-888-522-5372

**Fairchild Semiconductor  
Europe**  
Fax: +44 (0) 1793-856858  
Deutsch Tel: +49 (0) 8141-6102-0  
English Tel: +44 (0) 1793-856856  
Français Tel: +33 (0) 1-6930-3696  
Italiano Tel: +39 (0) 2-249111-1

**Fairchild Semiconductor  
Hong Kong**  
8/F, Room 808, Empire Centre  
68 Mody Road, Tsimshatsui East  
Kowloon, Hong Kong  
Tel: +852-2722-8338  
Fax: +852-2722-8383

**Fairchild Semiconductor  
Japan Ltd.**  
4F, Natsume Bldg.  
2-18-6, Yushima, Bunkyo-ku  
Tokyo, 113-0034 Japan  
Tel: 81-3-3818-8840  
Fax: 81-3-3818-8841

Fairchild does not assume any responsibility for use of any circuitry described, no circuit patent licenses are implied and Fairchild reserves the right at any time without notice to change said circuitry and specifications.