

SURFACE MOUNT SCHOTTKY BARRIER RECTIFIER

VOLTAGE 45 Volts CURRENT 3.0 Amperes

FEATURES

- * Low Profile Design for Smart Phone Charger
- * Ideal for SMT Mounting
- * High Forward Surge Capability
- * Low Forward Voltage Drop
- * Excellent High Temperature Stability

MECHANICAL DATA

- * Epoxy: Device has UL flammability classification 94V-O
- * Weight: 0.086 grams (approximate)

MAXIMUM RATINGS AND ELECTRICAL CHARACTERISTICS

Ratings at 25 °C ambient temperature unless otherwise specified.
Single phase, resistive or inductive load.



DO-214AA

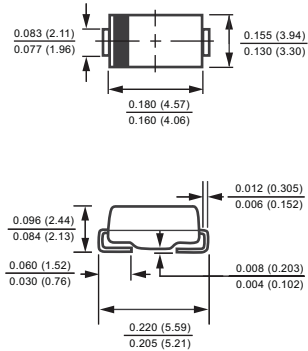

MAXIMUM RATINGS (@ TA=25 °C unless otherwise noted)

RATINGS	SYMBOL	FML345B	UNITS
Maximum Recurrent Peak Reverse Voltage	VRRM	45	Volts
Maximum RMS Voltage	VRMS	32	Volts
Maximum DC Blocking Voltage	Vdc	45	Volts
Maximum Average Forward Rectified Current @ T _T =100°C	I _O	3.0	Amps
Peak Forward Surge Current 8.3 ms single half sine-wave superimposed on rated load (JEDEC method)	I _{FSM}	90	Amps
Current Squared Time	I ² t	33.6	A ² /Sec
Thermal Resistance Junction to Ambient	R _{θJA}	58	°C/W
Thermal Resistance Junction to Soldering	R _{θJS}	20	°C/W
Operating Temperature Range	T _J	-55 to + 125	°C
Storage Temperature Range	T _{STG}	-55 to + 150	°C
Total Capacitance	C _T	75	pF

ELECTRICAL CHARACTERISTICS (@TA=25 °C unless otherwise noted)

CHARACTERISTICS	SYMBOL	FML345B	UNITS
Maximum Instantaneous Forward Voltage at 3.0A DC	V _F	0.45	Volts
Maximum Average Reverse Current at Rated DC Blocking Voltage	I _R	@TA = 25°C	1.5
		@TA = 80°C	60
			mAmps

NOTES : 1. Measured at 1 MHz and applied reverse voltage of 10 volts.
2. "Fully ROHS compliant", "100% Sn plating (Pb-free)".
3. Available for IR reflow & wave soldering

RATING AND CHARACTERISTICS CURVES (FML345B)

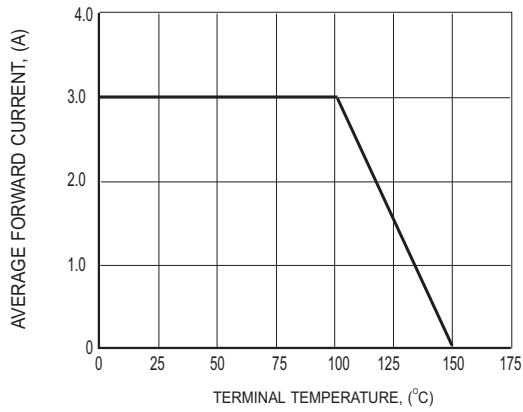

FIG.1 TYPICAL FORWARD CURRENT DERATING CURVE

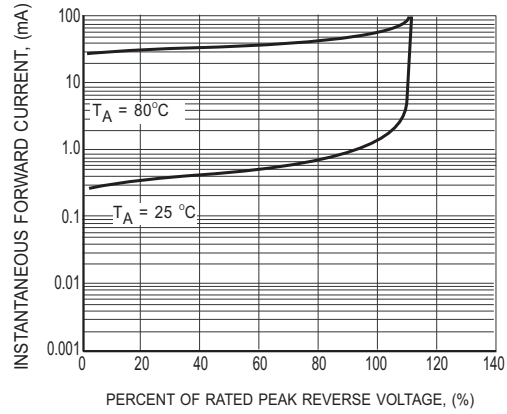

FIG.2 TYPICAL REVERSE CHARACTERISTICS

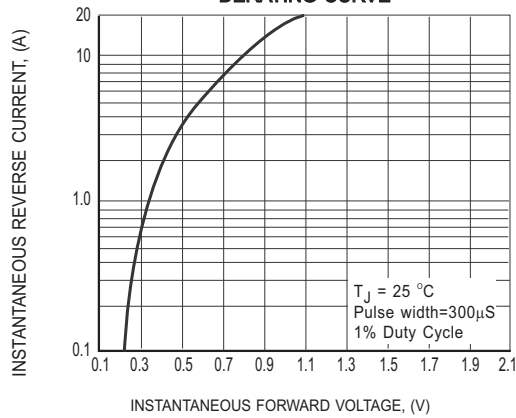

FIG.3 TYPICAL INSTANTANEOUS FORWARD CHARACTERISTICS

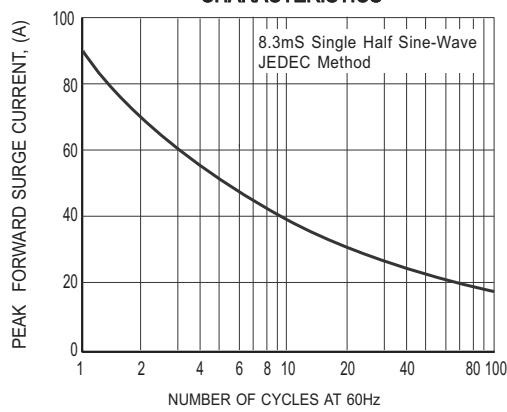
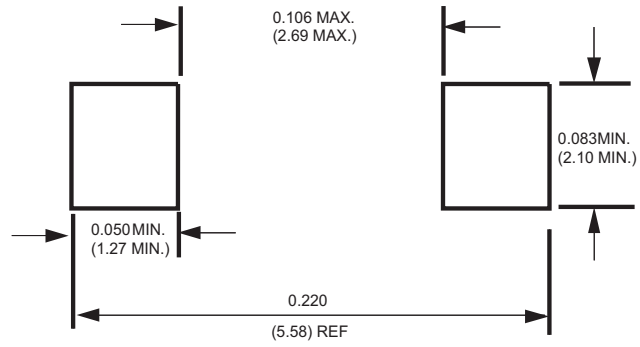

FIG.4 MAXIMUM NON-REPETITIVE FORWARD SURGE CURRENT

Mounting Pad Layout



Dimensions in inches and (millimeters)

Marking Description

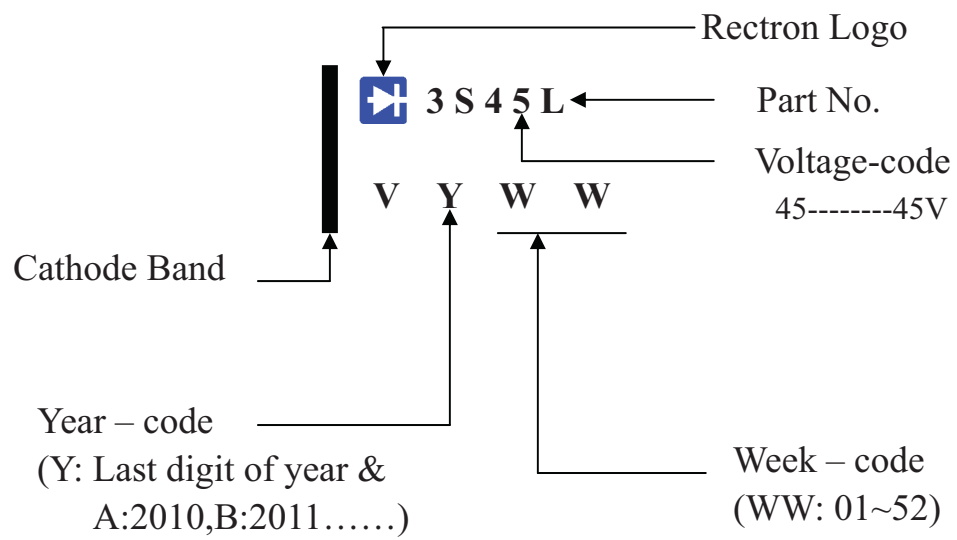

PACKAGING OF DIODE AND BRIDGE RECTIFIERS

REEL PACK

PACKAGE	PACKING CODE	EA PER REEL	EA PER INNER BOX	COMPONENT SPACE (mm)	TAPE SPACE (mm)	REEL DIA (mm)	CARTON SIZE (mm)	EA PER CARTON	GROSS WEIGHT(Kg)
SMB	-T	500	2,000	---	---	178	390*205*310	16,000	----
SMB	-W	3,000	6,000	---	---	330	360*355*360	48,000	13.90

1. BOX

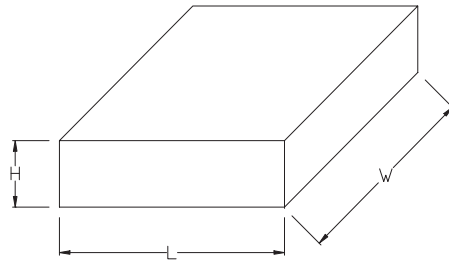

Packing Code	L (mm)	W (mm)	H (mm)
-T	182	182	68
-W	338	338	40

2. REEL

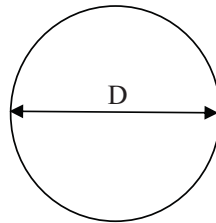

Packing Code	D (mm)
-T	178
-W	330

3. CARTON

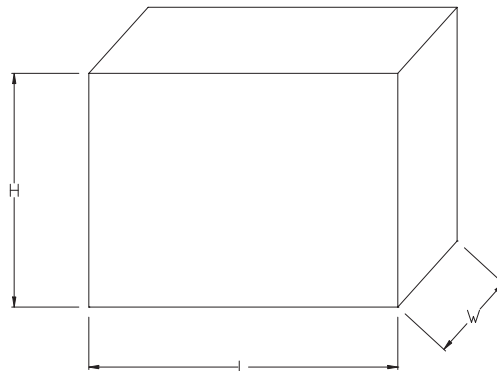

Packing Code	L (mm)	W (mm)	H (mm)
-T	390	205	310
-W	360	355	360

REEL TAPING SPECIFICATIONS FOR SURFACE MOUNT DEVICES-FLAT MELF (SMA/SMB/SMC)

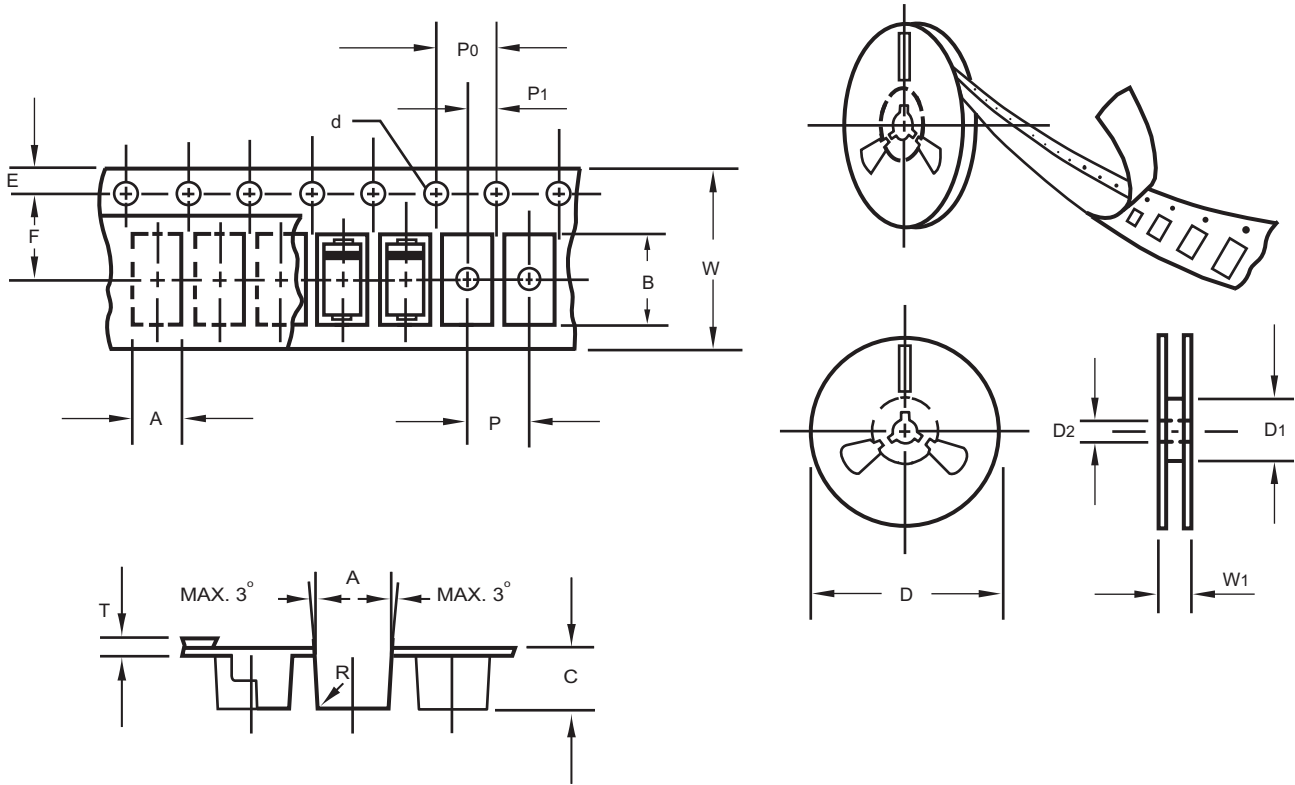

Fig.: Configuration of FLAT MELF TAPING
(SMA/SMB/SMC)

ITEM	SYMBOL	DO214AC (SMA) mm(inch)	DO214AA (SMB) mm(inch)	DO214AB (SMC) mm(inch)
Carrier width	A	2.6 ± 0.15 (0.102 ± 0.006)	3.65 ± 0.1 (0.144 ± 0.004)	6.0 ± 0.1 (0.236 ± 0.004)
Carrier length	B	5.15 ± 0.15 (0.203 ± 0.006)	5.69 ± 0.1 (0.224 ± 0.004)	8.30 ± 0.1 (0.327 ± 0.004)
Carrier depth	C	2.3 ± 0.15 (0.091 ± 0.006)	2.67 ± 0.1 (0.105 ± 0.004)	2.5 ± 0.1 (0.098 ± 0.004)
Sprocket hole	d	1.5 ± 0.1 (0.059 ± 0.004)	1.5 ± 0.1 (0.059 ± 0.004)	1.5 ± 0.1 (0.059 ± 0.004)
Reel outside diameter	D	178 ± 2.0 (7.0 ± 0.079)	178 ± 2.0 (7.0 ± 0.079)	178 ± 2.0 (7.0 ± 0.079)
Reel inner diameter	D1	50 Min.	50 Min.	50 Min.
Feed hole diameter	D2	13 ± 0.5 (0.512 ± 0.020)	13 ± 0.5 (0.512 ± 0.020)	13 ± 0.5 (0.512 ± 0.020)
Strocket hole position	E	1.5 ± 0.1 (0.059 ± 0.004)	1.5 ± 0.1 (0.059 ± 0.004)	1.5 ± 0.1 (0.059 ± 0.004)
Punch hole position	F	5.65 ± 0.05 (0.222 ± 0.002)	5.65 ± 0.05 (0.222 ± 0.002)	7.65 ± 0.05 (0.301 ± 0.002)
Punch hole pitch	P	4.0 ± 0.1 (0.157 ± 0.004)	8.0 ± 0.1 (0.315 ± 0.004)	8.0 ± 0.1 (0.315 ± 0.004)
Sprocket hole pitch	P0	4.0 ± 0.1 (0.157 ± 0.004)	4.0 ± 0.1 (0.157 ± 0.004)	4.0 ± 0.1 (0.157 ± 0.004)
Embossment center	P1	2.0 ± 0.1 (0.079 ± 0.004)	2.0 ± 0.1 (0.079 ± 0.004)	4.0 ± 0.1 (0.157 ± 0.004)
Total tape thickness	T	0.30 ± 0.05 (0.012 ± 0.002)	0.6 Max.	0.6 Max.
Tape width	W	12.0 ± 0.2 (0.472 ± 0.008)	12.0 ± 0.2 (0.472 ± 0.008)	16.0 ± 0.2 (0.630 ± 0.008)
Reel width	W1	16.8 ± 2.0 (0.661 ± 0.079)	16.8 ± 2.0 (0.661 ± 0.079)	24.0 ± 2.0 (0.945 ± 0.079)

Note: 1.Devices are packed in accordance with EIA standard RS-481-A and specification given above.
2.Available on 7 inch (1500 ct.) or 13 inch (5000 ct.) diameter reels.

DISCLAIMER NOTICE

Rectron Inc reserves the right to make changes without notice to any product specification herein, to make corrections, modifications, enhancements or other changes. Rectron Inc or anyone on its behalf assumes no responsibility or liability for any errors or inaccuracies. Data sheet specifications and its information contained are intended to provide a product description only. "Typical" parameters which may be included on RECTRON data sheets and/ or specifications can and do vary in different applications and actual performance may vary over time. Rectron Inc does not assume any liability arising out of the application or use of any product or circuit.

Rectron products are not designed, intended or authorized for use in medical, life-saving implant or other applications intended for life-sustaining or other related applications where a failure or malfunction of component or circuitry may directly or indirectly cause injury or threaten a life without expressed written approval of Rectron Inc. Customers using or selling Rectron components for use in such applications do so at their own risk and shall agree to fully indemnify Rectron Inc and its subsidiaries harmless against all claims, damages and expenditures.